

ARAB REPUBLIC OF EGYPT

**Ministry of Housing, Utilities
and Urban Development**

Housing and Building National Research Center



**EGYPTIAN CODE OF PRACTICE
FOR
STEEL CONSTRUCTION AND BRIDGES
(ALLOWABLE STRESS DESIGN - ASD)**

**Code No. (205)
Ministerial Decree No 279 - 2001**

**Permanent Committee for the Code of Practice
for Steel Construction and Bridges**



First Edition

2001



بِسْمِ اللّٰهِ الرَّحْمٰنِ الرَّحِیْمِ

Table of Contents

CHAPTER 1 :	MATERIALS	(1-5)
CHAPTER 2 :	ALLOWABLE STRESSES	(6-34)
CHAPTER 3 :	FATIGUE	(35-50)
CHAPTER 4 :	STABILITY AND SLENDERNESS RATIOS	(51-67)
CHAPTER 5:	STRUCTURAL WELDING	(68-93)
CHAPTER 6 :	BOLTED CONNECTIONS	(94-121)
CHAPTER 7:	PLATE GIRDERS	(122-126)
CHAPTER 8 :	TRUSS BRIDGES	(127-130)
CHAPTER 9 :	COMPLEMENTARY REQUIREMENTS FOR DESIGN AND CONSTRUCTION	(131-151)
CHAPTER 10 :	COMPOSITE STEEL-CONCRETE CONSTRUCTION	(152-182)
CHAPTER 11 :	COLD FORMED SECTIONS	(183-213)
CHAPTER 12 :	DIMENTIONAL TOLERANCES	(214-228)
CHAPTER 13 :	FABRICATION, ERECTION AND FINISHING WORKS	(229-248)
CHAPTER 14 :	INSPECTION AND MAINTENANCE OF STEEL BRIDGES	(249-255)
SUBJECT INDEX		(256-261)



CHAPTER 1

MATERIALS

1.1 GENERAL

Steel structures shall be made of structural steel, except where otherwise specified. Steel rivet shall be used for rivets only. Cast steel shall preferably be used for shoes, rockers and bearings. Forged steel shall be used for large pins, expansion rollers and other parts, as specified. Cast iron may be used only where specifically authorised.

The materials generally used in steel construction are described below. Special steels can be used provided that they are precisely specified and that their characteristics, such as yield stress, tensile strength, ductility and weldability, enable the present code to be put into application.

1.2 IDENTIFICATION

1.2.1 Certified report or manufacturer's certificates, properly correlated to the materials used, intended or other recognised identification markings on the product, made by the manufacturer of the steel material, fastener or other item to be used in fabrication or erection, shall serve to identify the material or item as to specification, type or grade.

1.2.2 Except as otherwise approved, structural steel not satisfactorily identified as to material specification shall not be used unless tested in an approved testing laboratory. The results of such testing, taking into account both mechanical and chemical properties, shall form the basis for classifying the steel as to specifications, and for the determination of the allowable stresses.



1.3 STRUCTURAL STEEL

The mechanical properties of structural steel shall comply with the requirement given in Clause 1.4. Under normal conditions of usual temperatures, calculations shall be made for all grades of steel based on the following properties.

Mass Density	$\rho = 7.85$	t/m^3
Modulus of Elasticity	$E = 2100$	t/cm^2
Shear Modulus	$G = 810$	t/cm^2
Poisson's Ratio	$\nu = 0.3$	
Coefficient of Thermal Expansion	$\alpha = 1.2 \times 10^{-5}$	$/^\circ C$

1.4 GRADES OF STEEL

Material conforming to the Egyptian Standard Specification No. **260/71** (Ministry of Industry) is approved for use under this code.

Grade of Steel	Nominal Values of Yield Stress F_y and Ultimate Strength F_u			
	Thickness t			
	$t \leq 40$ mm		40 mm $< t \leq 100$ mm	
	F_y (t/cm^2)	F_u (t/cm^2)	F_y (t/cm^2)	F_u (t/cm^2)
St 37	2.40	3.60	2.15	3.4
St 44	2.80	4.40	2.55	4.1
St 52	3.60	5.20	3.35	4.9



1.5 CAST STEEL

1.5.1 Steel castings shall be of one of the two following grades in accordance with the purpose for which they are to be used, as specified on the drawings and as prescribed in the special specification.

a- Castings of grade **C St 44** for all medium-strength carbon steel castings; for general use and in parts not subjected to wearing on their surfaces.

b- Castings of grade **C St 55** for all high-strength-carbon steel castings which are to be subjected to higher mechanical stresses than **C St 44**; for use in parts subjected to wearing on their surface such as pins, hinges, parts of bearings and machinery of movable bridges.

1.5.2 Steel for castings shall be made by the open-hearth process (acid or basic) or electric furnace process, as may be specified. On analysis it must show not more than **0.06%** of sulphur or phosphorus.

1.6 FORGED STEEL

1.6.1 The following prescriptions apply to carbon steel forging for parts of fixed and movable bridges.

The forging shall be of the following grades according to the purpose for which they are used:

a- Forging of grade **F St 50**, annealed or normalised; for mild steel forging of bearings, hinges, trunnions, shafts, bolts, nuts, pins, keys, screws, worms. Tensile strength from **5.0** to **5.6 t/cm²**; minimum yield point stress **2.4 t/cm²**.

b- Forging of grade **F St 56**, normalised, annealed or normalised and tempered; for various carbon steel machinery, bridge and structural forging of pinions, levers, cranks, rollers, tread plates. Tensile strength from **5.6** to **6.3 t/cm²**; minimum yield point stress **2.8 t/cm²**. The grade required shall be specified on the plans or in the special specification.



1.6.2 Carbon steel for forging shall be made by the open hearth or an electric process, acid or basic, as may be specified.

The steel shall contain not more than **0.05%** of sulphur or of phosphorus, **0.35%** of carbon, **0.8%** of manganese, **0.35%** of silicium.

1.7 CAST IRON

1.7.1 Where cast iron is used for such purposes as bearing plates and other parts of structures liable to straining actions, it shall comply with the following requirements.

Two test bars, each **100** cm long by **5** cm deep and **2.5** cm wide, shall be cast from each melting of the metal used. Each bar shall be tested being placed on edge on bearings **100** cm apart, and shall be required to sustain without fracture a load **1.40** ton at the centre with a deflection of not less than 8 mm. Cast iron of this standard strength shall be named **CI 14**.

1.7.2 Where cast iron is used for balustrades or similar purposes, in which the metal is not subjected to straining actions, no special tests for strength will be called for.

1.7.3 All iron castings shall be of tough grey iron with not more than **0.01%** sulphur.

1.8 WROUGHT IRON

Wrought iron, where employed in existing structures shall comply with the following requirements:

a- The tensile breaking strength of all plates, sections and flat bars shall in no case be less than **3.5 t/cm²**.

b- The yield point stress of all plates, sections and flat bars shall in no case be less than **2.2 t/cm²**.

c- The elongation measured on the standard test piece shall be not less than **12%**.



d- The ultimate shear strength of rivets and bolts, in case it is not possible to perform a tensile test on the material of the said rivets and bolts, shall in no case be less than **3.0 t/cm²**.



CHAPTER 2

ALLOWABLE STRESSES

2.1 GENERAL APPLICATION

The following prescriptions, together with any other provisions stipulated in the special specifications, are intended to apply to the design and construction of steel bridges and buildings.

The structural safety shall be established by computing the stresses produced in all parts and ascertaining that they do not exceed the allowable (working) stresses specified herein, when these parts are subjected to the most unfavourable conditions or combinations of the loads and forces according to the current Egyptian Code of Practice for Loads and Forces for Structural Elements. In applying the said prescriptions, approved scientific methods of design shall be used. Deflections shall be computed and they shall in no case exceed the limits herein after specified.

2.2 PRIMARY AND ADDITIONAL STRESSES

2.2.1 For the purpose of computing the maximum stress in a structure, the straining actions shall be calculated for two cases:

Case I: Primary Stresses Due to

Dead Loads + Live Loads or Superimposed Loads + Dynamic Effects + Centrifugal Forces.

Case II: Primary and Additional Stresses Due to

Case I + (Wind Loads or Earthquake Loads , Braking Forces, Lateral Shock Effect, Change of Temperature, Frictional Resistance of Bearings, Settlement of Supports in addition to the Effect of Shrinkage and Creep of Concrete).

2.2.2 Stresses due to Wind Loads shall be considered as primary for such structures as towers, transmission poles, wind bracing systems, etc.



2.2.3 In designing a structure members shall, in the first instance, be so designed that in no case the stresses due to case I exceed the allowable stresses specified in the present code.

The design should then be checked for case II (primary + additional stresses), and the stresses shall in no case exceed the aforesaid allowable stresses by more than **20%**.

2.3 SECONDARY STRESSES

Structures should be so designed, fabricated, and erected as to minimize, as far as possible, secondary stresses and eccentricities.

Secondary stresses are usually defined as bending stresses upon which the stability of the structure does not depend and which are induced by rigidity in the connections of the structure already calculated on the assumption of frictionless or pin-jointed connections.

In ordinary welded, bolted or riveted trusses without sub-panelling, no account usually needs to be taken of secondary stresses in any member whose depth (measured in the plane of the truss) is less than **1/10** of its length for upper and lower chord members, and **1/15** for web members. Where this ratio is exceeded or where sub-panelling is used, secondary stresses due to truss distortion shall be computed, or a decrease of **20%** in the allowable stresses prescribed in this code shall be considered (see also Clauses 8.4.4, 8.4.5, and 8.5.3).

Bending stresses in the verticals of trusses due to eccentric connections of cross-girders shall be considered as secondary.

The induced stresses in the floor members and in the wind bracing of a structure resulting from changes of length due to the stresses in the adjacent chords shall be taken into consideration and shall be considered as secondary.

Stresses which are the result of eccentricity of connections and which are caused by direct loading shall be considered as primary stresses.



For bracing members in bridges, the maximum allowable stresses shall not exceed **0.85** of the allowable stresses specified in this code if the bridge has not been considered as a space structure.

2.4 STRESSES DUE TO REPEATED LOADS

Members and connections subject to repeated stresses (whether axial, bending, or shearing) during the passage of the moving load shall be proportioned according to Chapter 3.

2.5 ERECTION STRESSES

Where erection stresses, including those produced by the weight of cranes, together with the wind pressure, would produce a stress in any part of structure in excess of **25%** above the allowable stresses specified in this code, such additional material shall be added to the section or other provision made, as is necessary, to bring the erection stresses within that limit.

2.6 ALLOWABLE STRESSES FOR STRUCTURAL STEEL

2.6.1 General

Allowable stresses for structural steel shall be determined according to the grade of steel used. Structural sections (subject to the requirements in Clause 2.7), shall be classified (depending on the maximum width-thickness ratios of their elements subject to compression) as follows:

Class 1. (compact sections):

Are those which can achieve the plastic moment capacity without local buckling of any of its compression elements.

Class 2. (non-compact sections):

Are those which can achieve the yield moment capacity without local buckling of any of its compression elements.

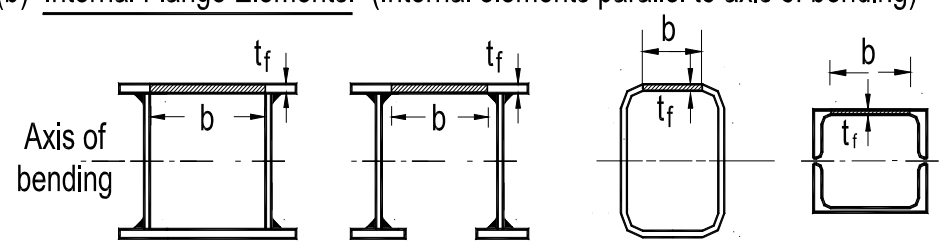
The limiting width to thickness ratios of class 1 and 2 compression elements are given in Table 2.1.

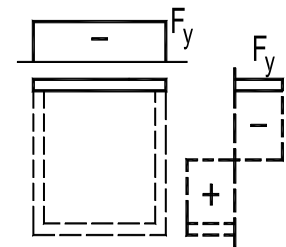
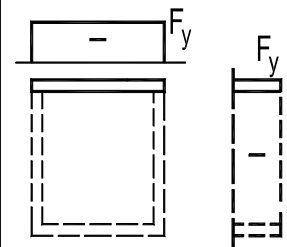
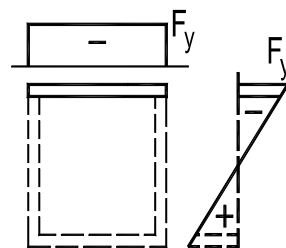
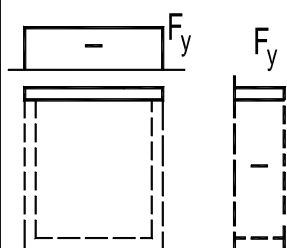


**Table (2.1a) Maximum Width to Thickness Ratios for Stiffened
Compression Elements**

**Table (2.1b) Maximum Width to Thickness Ratios for Stiffened
Compression Elements**

(b) Internal Flange Elements: (Internal elements parallel to axis of bending)



Class / Type	Section in Bending	Section in Compression
<p><u>1. Compact</u></p> <p>Stress distribution in element and across section.</p>		
	$\frac{b}{t_f} \leq \frac{58}{\sqrt{F_y}}$	$\frac{b}{t_f} \leq \frac{64}{\sqrt{F_y}}$
<p><u>2. Non-Compact</u></p> <p>Stress distribution in element and across section.</p>		
	$\frac{b}{t_f} \leq \frac{64}{\sqrt{F_y}}$	$\frac{b}{t_f} \leq \frac{64}{\sqrt{F_y}}$

F_y in t/cm^2



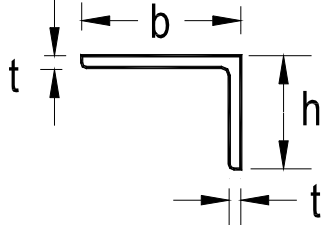
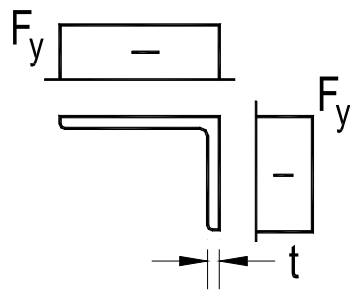
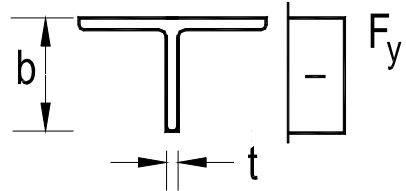
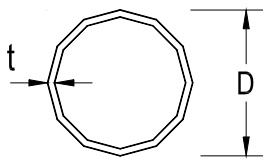
(c) Outstanding Flanges:

Class / Type	Flange Subject to Compression	Flange Subject to Compression and Bending	
		Tip in Compression	Tip in Tension
<u>1. Compact</u> Stress distribution in element.			
	Rolled Welded	$\frac{C}{t_f} \leq 16.9 / \sqrt{F_y}$ $\frac{C}{t_f} \leq 15.3 / \sqrt{F_y}$	$\frac{\alpha C}{t_f} \leq 16.9 / \sqrt{F_y}$ $\frac{\alpha C}{t_f} \leq 15.3 / \sqrt{F_y}$
<u>2. Non-Compact</u> Stress distribution in element.			
	Rolled Welded	$\frac{C}{t_f} \leq 23 / \sqrt{F_y}$ $\frac{C}{t_f} \leq 21 / \sqrt{F_y}$	$\frac{C}{t_f} \leq 35 \sqrt{k_\sigma / F_y}$ $\frac{C}{t_f} \leq 32 \sqrt{k_\sigma / F_y}$

F_y in t/cm^2

For k_σ see Tables 2.3 & 2.4

Table (2.1d) Maximum Width to Thickness Ratios for Compression Elements

<p>(d) <u>Angles:</u></p>  <p>(Does not apply to angles in continuous contact with other components)</p>	
Class	Section In Compression
Stress distribution across section	
<u>Non-compact</u>	$b/t \leq 23/\sqrt{F_y}$; $(b+h)/2t \leq 17/\sqrt{F_y}$ (*)
Class	Section In Compression
(e) <u>T-Section:</u>	
<u>Non-compact</u>	$b/t \leq 30/\sqrt{F_y}$
(f) <u>Tubular Section:</u>	
Class	Section In Bending and/or Compression
<u>1. Compact</u>	$D/t \leq 165/F_y$
<u>2. Non-Compact</u>	$D/t \leq 211/F_y$

F_y in t/cm^2

(*) For unequal leg angles



Class 3. (slender sections):

Are those which cannot achieve yield moment capacity without local buckling of any of its compression elements.

When any of the compression elements of a cross-section is classified as class 3, the whole cross-section shall be designed as a class 3 cross-section.

2.6.2 Allowable Stress in Axial Tension F_t

On the effective net area as defined in Clause 2.7.1:

$$F_t = 0.58 F_y \dots\dots\dots 2.1$$

Grade of Steel	F_t (t/cm ²)	
	$t \leq 40$ mm	40 mm $< t \leq 100$ mm
St 37	1.4	1.3
St 44	1.6	1.5
St 52	2.1	2.0

2.6.3 Allowable Stress in Shear q_{all}

2.6.3.1 On the gross effective area in resisting shear as defined below:

$$q_{all} = 0.35 F_y \dots\dots\dots 2.2$$

Grade of Steel	q_{all} (t/cm ²)	
	$t \leq 40$ mm	40 mm $< t \leq 100$ mm
St 37	0.84	0.75
St 44	0.98	0.89
St 52	1.26	1.17

The effective area in resisting shear of rolled shapes shall be taken as the full height of the section times the web thickness while for fabricated shapes it shall be taken as the web height between flanges times the web thickness.

In addition, the shear buckling resistance shall also be checked as specified in Clause 2.6.3.2 when:

- For unstiffened webs:

$$\frac{d}{t_w} > \frac{105}{\sqrt{F_y}} \dots\dots\dots 2.3$$

- For stiffened webs:

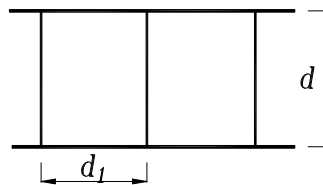
$$\frac{d}{t_w} > 45 \sqrt{\frac{k_q}{F_y}} \dots\dots\dots 2.4$$

Where: k_q = Buckling factor for shear

$$= 4 + (5.34/\alpha^2), \quad \text{for } \alpha \leq 1 \dots\dots\dots 2.5$$

$$= 5.34 + (4/\alpha^2), \quad \text{for } \alpha > 1 \dots\dots\dots 2.6$$

Where: d_1/d & d_1 = Spacing of transverse stiffeners



For unstiffened webs, $\alpha = \infty$ $k_q = 5.34$

2.6.3.2 Allowable Buckling Stress In Shear q_b

Depending on the web slenderness parameter:

$$\lambda_q = \frac{d/t_w}{57} \sqrt{\frac{F_y}{k_q}} \dots\dots\dots 2.7$$

The buckling shear stress is:

For $\lambda_q \leq 0.8$ $q_b = 0.35 F_y$ 2.8

$0.8 < \lambda_q < 1.2$ $q_b = (1.5 - 0.625 \lambda_q) (0.35 F_y)$ 2.9



$$\lambda_q \geq 1.2 \quad q_b = \frac{0.9}{\lambda_q} (0.35 F_y) \dots\dots\dots 2.10$$

2.6.4 Allowable Stress in Axial Compression F_c

On the gross section of axially loaded symmetric compression members (having compact, non-compact, or slender sections) in which the shear center coincides with the center of gravity of the section and meeting all the width-thickness ratio requirements of Clause 2.6.1:

For $\lambda =$ slenderness ratio = $k\ell / r < 100$ (see Chapter 4 for definition of terms):

$$F_c = 0.58F_y - \frac{(0.58F_y - 0.75)}{10^4} \lambda^2 \dots\dots\dots 2.11$$

Grade of Steel	F_c (t/cm ²)		
	$t \leq 40$ mm	40 mm $< t \leq 100$ mm	
St 37	$F_c = (1.4 - 0.000065\lambda^2)$	$F_c = (1.3 - 0.000055\lambda^2)$	2.12
St 44	$F_c = (1.6 - 0.000085\lambda^2)$	$F_c = (1.5 - 0.000075\lambda^2)$	2.13
St 52	$F_c = (2.1 - 0.000135\lambda^2)$	$F_c = (2.0 - 0.000125\lambda^2)$	2.14

For all grades of steel:

For $\lambda = k\ell/r \geq 100$:

$$F_c = 7500/\lambda^2 \dots\dots\dots 2.15$$

For compact and non-compact sections, the full area of the section shall be used, while for slender sections, the effective area shall be used, as given in Tables 2.3 & 2.4.

In case of sections eccentrically connected to gusset plates (e.g., one angle), unless a more accurate analysis is used, the allowable compressive stresses shall be reduced by **40%** of F_c in case the additional bending stresses due to eccentricity are not calculated.



2.6.5 Allowable Stress in Bending F_b

2.6.5.1 Tension and compression due to bending on extreme fibers of “compact” sections symmetric about the plane of their minor axis and bent about their major axis:

$$F_b = 0.64 F_y \dots\dots\dots 2.16$$

Grade of Steel	F_b (t/cm ²)	
	$t \leq 40$ mm	40 mm $< t \leq 100$ mm
St 37	1.54	1.38
St 44	1.76	1.63
St 52	2.30	2.14

In order to qualify under this section:

- 1- The member must meet the compact section requirements of Table 2.1.
- 2- The laterally unsupported length (L_u) of the compression flange is limited by the smaller of:

i- For box sections:

$$\left. \begin{aligned} L_u &< \frac{84}{F_y} b_f \\ \text{Or} \\ L_u &\leq \left(137 + 84 \frac{M_1}{M_2}\right) b_f / F_y \end{aligned} \right\} \dots\dots\dots 2.17$$

ii- For other sections:

$$\left. \begin{aligned} L_u &\leq \frac{20b_f}{\sqrt{F_y}} \\ \text{Or} \\ L_u &\leq \frac{1380A_f}{dF_y} C_b \end{aligned} \right\} \dots\dots\dots 2.18$$



Where b_f is the compression flange width, M_1/M_2 is the algebraic ratio of the smaller to the larger end moments taken as positive for reverse curvature bending, d is the beam depth and C_b is given in Equation 2.28.

2.6.5.2 Tension and compression due to bending on extreme fibers of doubly symmetrical I-shape members meeting the compact section requirements of Tables 2.1a & 2.1c, and bent about their minor axis; solid round and square bars; solid rectangular sections bent about their minor axis:

$$F_b = 0.72 F_y \dots\dots\dots 2.19$$

2.6.5.3 Tension and compression on extreme fibers of rectangular tubular sections meeting the compact section requirements of Tables 2.1a & 2.1b, and bent about their minor axis:

$$F_b = 0.64 F_y \dots\dots\dots 2.20$$

2.6.5.4 Tension and compression on extreme fibers of box-type flexural members meeting the “non-compact” section requirements of Table 2.1b, and bent about either axis:

$$F_b = 0.58 F_y \dots\dots\dots 2.21$$

2.6.5.5 On extreme fibers of flexural members not covered by Clauses 2.6.5.1 – 2.6.5.4:

Tension F_{bt}

$$F_{bt} = 0.58 F_y \dots\dots\dots 2.22$$

Hence, F_{bt} is taken as follows:

Grade of Steel	F_{bt} (t/cm ²)	
	$t \leq 40$ mm	40 mm $< t \leq 100$ mm
St 37	1.4	1.3
St 44	1.6	1.5
St 52	2.1	2.0



2- Compression F_{bc}

I. When the compression flange is braced laterally at intervals exceeding L_u as defined by Equations 2.17 or 2.18, the allowable bending stress in compression F_{bc} will be taken as the larger value from Equations 2.23 and 2.24, 2.25, or 2.26 with a maximum value of $0.58 F_y$:

i- For shallow thick flanged sections, where approximately ($\frac{t_f L_u}{b_f d} > 10$), for any value of L_u/r_T , the lateral torsional buckling stress is governed by the torsional strength given by:

$$F_{ltb_1} = \frac{800}{L_u \cdot d / A_f} C_b \leq 0.58 F_y \quad \text{2.23}$$

ii- For deep thin flanged sections, where approximately ($\frac{t_f L_u}{b_f d} < 0.40$), the lateral torsional buckling stress is governed by the buckling strength given by:

a- When $L_u / r_T < 84 \sqrt{\frac{C_b}{F_y}}$, then:

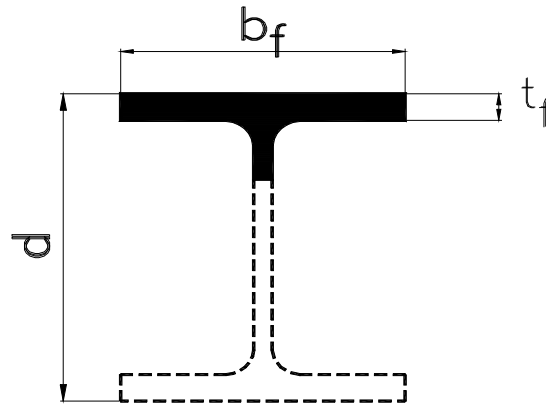
$$F_{ltb_2} = 0.58 F_y \quad \text{2.24}$$

b- When $84 \sqrt{\frac{C_b}{F_y}} \leq L_u / r_T \leq 188 \sqrt{\frac{C_b}{F_y}}$, then:

$$F_{ltb_2} = \left(0.64 - \frac{(L_u / r_T)^2 F_y}{1.176 \times 10^5 C_b}\right) F_y \leq 0.58 F_y \quad \text{2.25}$$

c- When $L_u / r_T > 188 \sqrt{\frac{C_b}{F_y}}$, then:

$$F_{ltb_2} = \frac{12000}{(L_u / r_T)^2} C_b \leq 0.58 F_y \quad \text{2.26}$$



Alternatively, the lateral torsional buckling stress can be computed more accurately as the resultant of the above mentioned two components as:

$$F_{ltb} = \sqrt{F_{ltb_1}^2 + F_{ltb_2}^2} \leq 0.58 F_y \dots\dots\dots 2.27$$

In the above Equations:

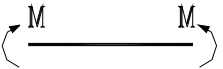

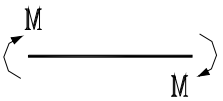
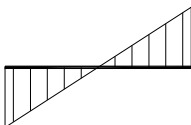
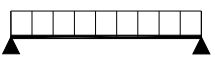
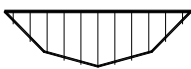
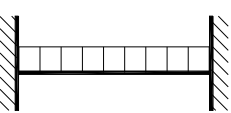
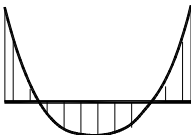
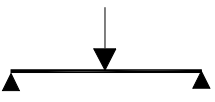
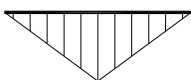
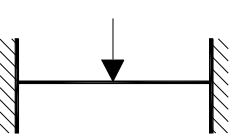
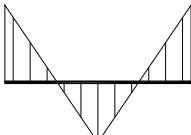

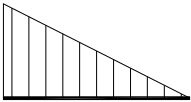
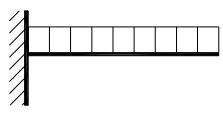
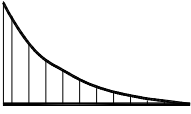
- L_u = Effective laterally unsupported length of compression flange.
= K^* (distance between cross-sections braced against twist or lateral displacement of the compression flange in cm).
- K = Effective length factor (as given in Chapter 4).
- r_T = Radius of gyration about the minor axis of a section comprising the compression flange plus one sixth of the web area (cm).
- A_f = ($b_f * t_f$) Area of compression flange (cm²).
- b_f = Compression flange width (cm).
- d = Total depth (cm).
- F_y = Yield stress (t/cm²).
- t_f = Compression flange thickness (cm).
- C_b = Coefficient depending on the type of load and support conditions as given in Table 2.2. For cases of unequal end moments without transverse loads, (C_b) can be computed from the expression:

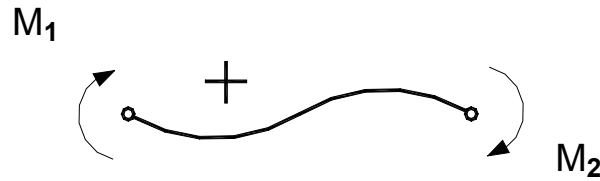
$$C_b = 1.75 + 1.05 (M_1/M_2) + 0.3 (M_1/M_2)^2 \leq 2.3 \quad 2.28$$

.....



Table (2.2) Values of Coefficients K and C_b

Loading	Bending Moment Diagram	End Restraint About Y-axis	Effective Length Factor K	C_b
		Simple	1.0	1.00
		Fixed	0.5	1.00
		Simple	1.0	2.30
		Fixed	0.5	2.30
		Simple	1.0	1.13
		Fixed	0.5	1.00
		Simple	1.0	1.30
		Fixed	0.5	0.90
		Simple	1.0	1.35
		Fixed	0.5	1.07
		Simple	1.0	1.70
		Fixed	0.5	1.04
		Warping Restrained	1.0	1.50
		Restrained	1.0	2.10



Where:

(M_1/M_2) is the algebraic ratio of the smaller to the larger end moments taken as positive for reverse curvature bending.

When the bending moment at any point within the unbraced length is larger than the values at both ends of this length, the value of (C_b) shall be taken as unity.

II. Compression on extreme fibres of channels bent about their major axis and meeting the requirements of Table 2.1.

$$F_{ltb} = \frac{800}{L_u \cdot d / A_f} C_b \leq 0.58 F_y \quad \dots\dots\dots 2.29$$

III. Slender sections which do not meet the non-compact section requirements of Table 2.1 shall be designed using the same allowable stresses used for non-compact sections except that the section properties used in the design shall be based on the effective widths b_e of compression elements as specified in Table 2.3 for stiffened elements and Table 2.4 for unstiffened elements. The effective width is calculated using a reduction factor ρ as $b_e = \rho \bar{b}$ where:

$$\rho = (\bar{\lambda}_p - 0.15 - 0.05\psi) / \bar{\lambda}_p^2 \leq 1 \quad \dots\dots\dots 2.30$$

and

$\bar{\lambda}_p$ = normalized plate slenderness given by:

$$\bar{\lambda}_p = \frac{\bar{b}/t}{44} \sqrt{\frac{F_y}{k_\sigma}} \quad \dots\dots\dots 2.31$$

k_σ = Plate buckling factor which depends on the stress ratio ψ as shown in Tables 2.3 and 2.4.

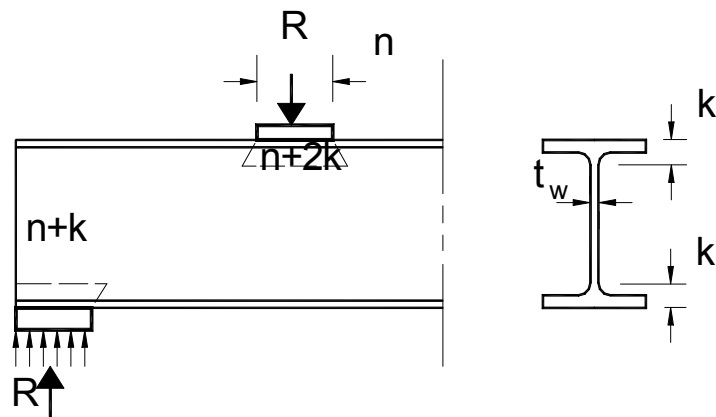
\bar{b} = Appropriate width, (see Table 2.1) as follows:

- \bar{b} = d_w for webs
- \bar{b} = b for internal flange elements (except rectangular hollow sections)
- \bar{b} = $b-3t$ for flanges of rectangular hollow sections
- \bar{b} = C for outstanding flanges
- \bar{b} = b for equal leg angles
- \bar{b} = b or $(b+h)/2$ for unequal leg angles
- \bar{b} = b for stem of T-section
- t = relevant thickness

2.6.6 Allowable Crippling Stress in Web F_{crp}

Web crippling is a localised yielding that arises from high compressive stresses occurring in the vicinity of heavy concentrated loads.

On the web of rolled shapes or built-up I-sections, at the toe of the fillet, the allowable crippling stress shall not exceed:

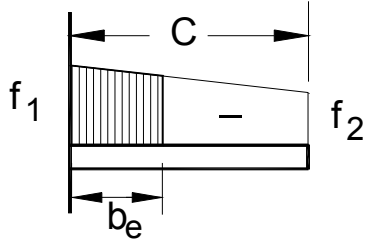
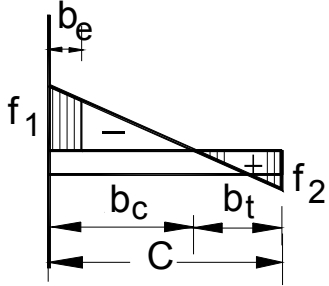
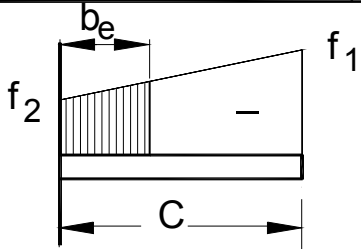
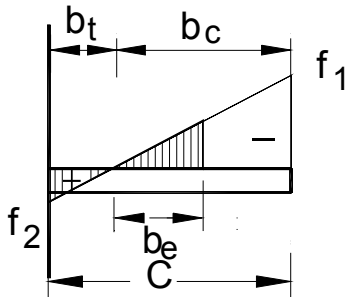


$$F_{crp} = 0.75 F_y \dots\dots\dots 2.32$$

Grade of Steel	F_{crp} (t/cm ²)	
	$t \leq 40$ mm	40 mm $< t \leq 100$ mm
St 37	1.8	1.6
St 44	2.1	1.9
St 52	2.7	2.5



Stress Distribution		Effective Width b_e for $\rho = (\bar{\lambda}_p - 0.15 - 0.05\psi) / \bar{\lambda}_p^2 \leq 1$				
For $1 > \psi \geq -1$:						$-1 > \psi > -2$
$k_\sigma = \frac{16}{[(1+\psi)^2 + 0.112(1-\psi)^2]^{0.5} + (1+\psi)}$						
$\psi = f_2 / f_1$	1	$1 > \psi > 0$	0	$0 > \psi > -1$	-1	
Buckling Factor k_σ	4.0	$\frac{8.2}{1.05 + \psi}$	7.81	$7.81 - 6.29\psi + 9.78\psi^2$	23.9	$5.98(1-\psi)^2$
			$\psi = 1:$ $b_e = \rho \bar{b}$ $b_{e1} = 0.5 b_e$ $b_{e2} = 0.5 b_e$			
			$1 > \psi \geq 0:$ $b_e = \rho \bar{b}$ $b_{e1} = 2 b_e / (5 - \psi)$ $b_{e2} = b_e - b_{e1}$			
			$\psi < 0:$ $b_e = \rho b_c = \rho \bar{b} / (1 - \psi)$ $b_{e1} = 0.4 b_e$ $b_{e2} = 0.6 b_e$			

Stress Distribution		Effective Width b_e for $\rho = (\bar{\lambda}_p - 0.15 - 0.05\psi) / \bar{\lambda}_p^2 \leq 1$			
$\psi = f_2 / f_1$	1	$1 > \psi > 0$	0	$0 > \psi > -1$	-1
Buckling factor k_σ	0.43	$\frac{0.578}{\psi + 0.34}$	1.70	$1.7 - 5\psi + 17.1\psi^2$	23.8
		$1 > \psi \geq 0:$ $b_e = \rho C$			
		$\psi < 0:$ $b_e = \rho b_c = \rho C / (1 - \psi)$			
$\psi = f_2 / f_1$	1	0	-1	$1 > \psi > -1$	
Buckling factor k_σ	0.43	0.57	0.85	$0.57 - 0.21\psi + 0.07\psi^2$	
		$1 > \psi \geq 0:$ $b_e = \rho C$			
		$\psi < 0:$ $b_e = \rho b_c = \rho C / (1 - \psi)$			



The crippling stress (f_{crp}) at the web toes of the fillets resulting from concentrated loads (R) not supported by stiffeners shall be calculated from the following Equations:

$$f_{crp} = \frac{R}{t_w(n+2k)} \quad \text{for interior loads} \quad \dots\dots\dots 2.33$$

$$f_{crp} = \frac{R}{t_w(n+k)} \quad \text{for edge loads} \quad \dots\dots\dots 2.34$$

2.6.7 Combined Stresses

2.6.7.1 Axial Compression and Bending

Members subjected to combined axial compression (N) and simple bending moment (M) about the major axis, shall be proportioned to satisfy the following interaction Equation:

$$\frac{f_{ca}}{F_c} + \frac{f_{bcx}}{F_{bcx}} A_1 + \frac{f_{bcy}}{F_{bcy}} A_2 \leq 1.0 \quad \dots\dots\dots 2.35$$

For cases when $f_{ca}/F_c < 0.15$, $A_1 = A_2 = 1.0$
otherwise:

$$A_1 = \frac{C_{mx}}{(1 - \frac{f_{ca}}{F_{Ex}})}, \quad A_2 = \frac{C_{my}}{(1 - \frac{f_{ca}}{F_{Ey}})}$$

Where:

- f_{ca} = Actual compressive stress due to axial compression.
- F_c = The allowable compressive stress, as appropriate, prescribed in Clause 2.6.4.
- f_{bcx}, f_{bcy} = The actual compressive bending stresses based on moments about the x and y axes, respectively.
- F_{bcx}, F_{bcy} = The allowable compressive bending stresses for the x and y axes, respectively, considering the member loaded in bending only as prescribed in Clause 2.6.5.
- F_{Ex}, F_{Ey} = The Euler stress divided by a factor of safety for buckling in the x and y directions, respectively (t/cm^2).



$$F_{Ex} = \frac{7500}{\lambda_x^2}, \quad F_{Ey} = \frac{7500}{\lambda_y^2} \quad 2.36$$

.....
C_m = Moment modification factor, and is to be taken according to the following:

a- For frames prevented from sway without transverse loading between supports **C_m = 0.6 - 0.4 (M₁/ M₂) > 0.4** where the end moments **M₁** and **M₂** carry a sign in accordance with the end rotational direction; i.e., positive moment ratio for reverse curvature and negative moment ratio for single curvature (**M₂ > M₁**).

b- For frames prevented from sway with transverse lateral loading between supports, **C_m** may be taken as:

i- For members with moment restraint at the ends, **C_m = 0.85**.

ii- For members with simply supported ends, **C_m = 1.0**.

c- For frames permitted to sway, **C_m = 0.85**.

In addition, sections at critical locations, e.g., at member ends, shall satisfy the following Equation:

$$\frac{f_{ca}}{F_c} + \frac{f_{bcx}}{F_{bcx}} + \frac{f_{bcy}}{F_{bcy}} \leq 1.0 \quad \dots\dots\dots 2.37$$

2.6.7.2 Axial Tension and Bending

Members subjected to combined axial tension "N" and bending moment "M" shall be proportioned to satisfy the following conditions:

$$\frac{f_{ta}}{F_t} + \frac{f_{btx}}{F_{btx}} + \frac{f_{bty}}{F_{bty}} \leq 1.0 \quad \dots\dots\dots 2.38$$

Where:

- f_{ta}** = Actual tensile stress due to axial tension.
- F_t** = The allowable tensile stress prescribed in Clause 2.6.2.
- f_{btx}, f_{bty}** = The actual tensile bending stresses based on moments about the x and y axes, respectively.
- F_{btx}, F_{bty}** = The allowable tensile bending stresses for the x and y

axes, respectively, considering the member loaded in bending only as prescribed in Clause 2.6.5.

In addition, the compressive bending stress alone shall be checked against the lateral torsional buckling stress.

2.6.8 Equivalent Stress f_e

Whenever the material is subjected to axial and shear stresses, the equivalent stress (f_e) must not exceed the permitted stresses given in this code plus **10%**, and the equivalent stress shall be calculated as follows:

$$f_e = \sqrt{f^2 + 3q^2} \leq 1.1 F_{all} \quad \dots\dots\dots 2.39$$

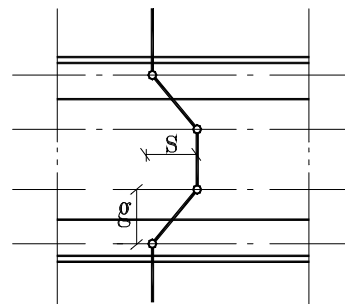
2.7 EFFECTIVE AREAS

2.7.1 Effective Net Area

The effective net sectional-area of a tension member shall be used. This area is the sum of the products of the thickness and net width of each element as measured normal to the axis of the member. For a chain of holes extending across a part in any diagonal or zigzag line, the net width of the parts shall be obtained by deducting from the gross width the sum of the diameters of all holes in the chain and adding, for each gauge space in the chain, the quantity ($s^2/4g$).

Where:

s = The staggered pitch, i.e., the distance, measured parallel to the direction of stress in the member, centre to centre of holes in consecutive lines.



t = The thickness of the material.

g = The gauge, i.e., the distance, measured at right angles to the direction of stress in the member, centre to centre of holes in consecutive lines.



2.7.2 Gross Sectional-Area

The gross sectional-area measured normal to the axis of the member shall be considered for all compression members except where holes are provided for black bolts in which case such holes shall be deducted.

The gross moment of inertia and the gross statical moment shall be used in calculating the shearing stress in plate girders and rolled beams.

2.8 ALLOWABLE STRESSES IN STANDARD GRADE STRUCTURAL STEEL CONFORMING TO THE EGYPTIAN STANDARD SPECIFICATION

These stresses are to be used for structures subjected to static loads or moving loads as well as for roadway and railway bridges.

The maximum stresses shall in no case exceed the values (t/cm^2) indicated in Table 2.5.

2.9 ALLOWABLE STRESSES IN CAST AND FORGED STEELS

2.9.1 The allowable stresses for tension, compression, and bending in cast steel of the grade **CST 44** shall not exceed the allowable stresses prescribed in Clause 2.8 for structural steel **St 44**.

The allowable stresses for tension, compression, and bending in cast steel of the grade **CST 55**, shall not exceed the allowable stresses indicated in Table 2.6.

2.9.2 The allowable stresses in forged steel of the grade **FST 56** shall not exceed the allowable stresses given in Table 2.6.



Table (2.5a) Allowable Stresses in Standard Grade Structural Steel (Thickness $t \leq 40$ mm)

Cause of Stress	Grade Of Steel	Tension $F_t = 0.58 F_y$ (t/cm ²)	Compression and Buckling F_c (t/cm ²) ^{*(1)}		Tension and Compression due to Bending $F_b = 0.64 F_y$ ^{*(2)} (t/cm ²)	Tension and Compression due to Bending $F_{bt} = 0.58 F_y$ ^{*(3)} (t/cm ²)	Shear in Web $q_{all} = 0.35 F_y$ ^{*(4)} (t/cm ²)
			$K\ell/r < 100$	$K\ell/r \geq 100$			
I- Primary Stresses							
Dead Load	St 37	1.4	$1.4 - 0.000065(K\ell/r)^2$	$7500/(K\ell/r)^2$	1.54	1.4	0.84
Live Load	St 44	1.6	$1.6 - 0.000085(K\ell/r)^2$	$7500/(K\ell/r)^2$	1.76	1.6	0.96
Dynamic Effect	St 52	2.1	$2.1 - 0.000135(K\ell/r)^2$	$7500/(K\ell/r)^2$	2.30	2.1	1.26
Centrifugal Force							
II- Primary and Additional Stresses ^{*(5)}	<u>All values are 20% higher than for item I</u>						

*(1) For axially loaded symmetric sections.

*(2) For compact sections satisfying the requirements of Clause 2.6.5.1.

*(3) For compact sections not satisfying the requirements of Clause 2.6.5.1 or non-compact sections satisfying the requirements of Clause 2.6.5.5.

*(4) For sections satisfying the buckling requirements of Clause 2.6.3.1.

*(5) Dead Load, Live Load, Dynamic Effect, Centrifugal Force, (Wind Pressure or Earthquake Loads), Braking Force, Lateral Shocks, Temperature Effect, Frictional Resistance of Bearings, Settlement of Supports & Shrinkage and Creep of Concrete.



Table (2.5b) Allowable Stresses in Standard Grade Structural Steel ($100 \text{ mm} \geq \text{Thickness } t > 40 \text{ mm}$)

Cause of Stress	Grade Of Steel	Tension $F_t = 0.58 F_y$ (t/cm ²)	Compression and Buckling F_c (t/cm ²) ^{*(1)}		Tension and Compression due to Bending $F_b = 0.64 F_y$ ^{*(2)} (t/cm ²)	Tension and Compression due to Bending $F_{bt} = 0.58 F_y$ ^{*(3)} (t/cm ²)	Shear in Web $q_{all} = 0.35 F_y$ ^{*(4)} (t/cm ²)
			$K\ell/r < 100$	$K\ell/r \geq 100$			
I- Primary Stresses							
Dead Load	St 37	1.3	$1.3 - 0.000055(K\ell/r)^2$	$7500/(K\ell/r)^2$	1.38	1.3	0.75
Live Load	St 44	1.5	$1.5 - 0.000075(K\ell/r)^2$	$7500/(K\ell/r)^2$	1.63	1.5	0.89
Dynamic Effect	St 52	2.0	$2.0 - 0.000125(K\ell/r)^2$	$7500/(K\ell/r)^2$	2.14	2.0	1.17
Centrifugal Force							
II- Primary and Additional Stresses ^{*(5)}	<u>All values are 20% higher than for item I</u>						

***(1)** For axially loaded symmetric sections.

***(2)** For compact sections satisfying the requirements of Clause 2.6.5.1.

***(3)** For compact sections not satisfying the requirements of Clause 2.6.5.1 or non-compact sections satisfying the requirements of Clause 2.6.5.5.

***(4)** For sections satisfying the buckling requirements of Clause 2.6.3.1.

***(5)** Dead Load, Live Load, Dynamic Effect, Centrifugal Force, (Wind Pressure or Earthquake Loads), Braking Force, Lateral Shocks, Temperature Effect, Frictional Resistance of Bearings, Settlement of Supports & Shrinkage and Creep of Concrete.



2.10 ALLOWABLE STRESSES IN BEARINGS AND HINGES

2.10.1 Table 2.6 gives the allowable stresses in (t/cm²) in the parts of bearings and hinges made of cast iron, cast steel, and forged steel of the qualities specified in Chapter 1, and subject to bending or compression.

Table (2.6) Allowable Stresses in Parts of Bearings and Hinges.

Material	Primary Stresses (t/cm ²)	
	Bending	Compression
Cast steel CST 55	1.80	1.80
Forged steel FST 56	2.00	2.00
Cast Iron CI 14:		
Tension	0.30	
Compression	0.60	0.90

The aforesaid allowable stresses may be exceeded by **20%** when the maximum combination of primary and additional stresses is taken into account.

2.10.2. According to Hertz formula, the bearing pressure when the surface of contact between the different parts of bearing are lines or points, is calculated as follows:

a. Case of Bearing Between Two Cylinders:

Case 1

$$f_{\max} = 0.423 \sqrt{\frac{E V}{\ell} \left(\frac{1}{r_2} + \frac{1}{r_1} \right)} \dots\dots\dots 2.40$$

Case 2

$$f_{\max} = 0.423 \sqrt{\frac{E V}{\ell} \left(\frac{1}{r_2} - \frac{1}{r_1} \right)} \dots\dots\dots 2.41$$

b. Case of Bearing Between a Cylinder and a Plane Surface:

$$f_{\max} = 0.423 \sqrt{\frac{E V}{\ell}} \dots\dots\dots 2.42$$



c. Case of Bearing Between Two Spheres:

Case 1

(Bearing between full sphere against full sphere)

$$f_{\max} = 0.394 \sqrt[3]{E^2 V \left(\frac{1}{r_1} + \frac{1}{r_2} \right)^2} \dots\dots\dots 2.43$$

Case 2

(Bearing between full sphere against hollow sphere)

$$f_{\max} = 0.394 \sqrt[3]{E^2 V \left(\frac{1}{r_2} - \frac{1}{r_1} \right)^2} \dots\dots\dots 2.44$$

d. Case of Bearing Between a Sphere and a Plane Surface:

$$f_{\max} = 0.394 \sqrt[3]{\frac{E^2 V}{r^2}} \dots\dots\dots 2.45$$

Where:

- f_{\max} = Maximum actual bearing pressure at the surface of contact (t/cm²).
- r_1 = The bigger radius of cylinder or sphere (cm).
- r_2 = The smaller radius of cylinder or sphere (cm).
- r = Radius of cylinder or sphere (cm).
- E = Young's modulus (t/cm²).
- V = Maximum load on bearing (ton).
- ℓ = Bearing length (cm).

For fixed, sliding, and movable bearings with one or two rollers, the allowable bearing stresses (t/cm²) shall be as given below, when the surface of contact between the different parts of a bearing are lines or points and when their design is carried out according to Hertz formula, assuming these bearings are subjected only to the primary stresses designated in Clause 2.2.1.



Material	Allowable Bearing Stress (t/cm ²)
For Cast Iron CI 14	5.00
For Rolled Steel St 44	6.50
For Cast Steel CST 55	8.50
For Forged Steel FST 56	9.50

2.10.3 The allowable load **V** (ton) on a cylindrical expansion roller shall not exceed the following values:

Material	Allowable Reaction (ton)
Rolled steel St 37	0.040 d.l
Rolled steel St 44	0.055 d.l
Cast steel CST 55	0.095 d.l
Forged steel FST 56	0.117 d.l

Where:

d = Diameter of roller (cm).

ℓ = Length of roller (cm).

In the case of movable bearings with more than two rollers, where the compressive force affecting the said rollers cannot be equally shared by all their parts, the aforesaid allowable reactions shall be increased by **20%**.

2.10.4 When bearings are provided with cylindrical cast steel knuckle pins, the diameter (**d**) of the pins shall be given by the formula:

$$\mathbf{d = \frac{4}{3} \cdot \frac{V}{\ell} \dots\dots\dots 2.46}$$

Where:

d = Diameter of pin (cm).

V = Vertical load (ton).

ℓ = Length of pin (cm).

The bearing pressure between pins made of cast or forged steel and the gusset plates shall not exceed **2.40 t/cm²**.

2.11 AREA OF BEARINGS OR BEDPLATES

The contact area of bearings or bedplates shall be so proportioned that the pressure due to the primary stresses on the materials forming the bearing base foundation shall not exceed the values (kg/cm²) indicated in Table 2.7:

Table (2.7) Allowable Bearing Stresses on the Materials Forming the Bearing Foundations

Type Of Bearing	Allowable Bearing Stress (kg/cm ²)
<p>Pressure on lead sheeting or cement mortar layer between the metal bearing plates and:</p> <ul style="list-style-type: none"> a. Bearing stones made of granite, basalt, or similar hard stones. b. Concrete templates reinforced with circular hoops or heavily reinforced caps under the bearings. 	<p style="text-align: center;">40</p> <p style="text-align: center;">70 for C 250</p> <p style="text-align: center;">110 for C 350</p>



CHAPTER 3

FATIGUE

3.1 SCOPE

3.1.1 General

This Chapter presents a general method for the fatigue assessment of structures and structural elements that are subjected to repeated fluctuations of stresses.

Members subjected to stresses resulting from fatigue loads shall be designed so that the maximum unit stresses do not exceed the basic allowable unit stress given in Chapter 2, and that the stress range does not exceed the allowable fatigue stress range given in this Chapter.

Members subjected to stresses resulting from wind forces only, shall be designed so that the maximum unit stress does not exceed the basic allowable unit stress given in Chapter 2.

Cracks that may form in fluctuating compression regions are self-arresting. Therefore, these compression regions are not subjected to fatigue failure.

3.1.2 Definitions

Fatigue: Damage in a structural member through gradual crack propagation caused by repeated stress fluctuations.

Design Life: The period in which a structure is required to perform safely with an acceptable probability that it will not fail or require repair.

Stress Range: The algebraic difference between two extreme values or nominal stresses due to fatigue loads. This may be determined through standard elastic analysis.

Fatigue Strength: The stress range determined from test data for a given number of stress cycles.



Fatigue Limit: The maximum stress range for constant amplitude cycles that will not form fatigue cracks.

Detail Category: The designation given to a particular joint or welded detail to indicate its fatigue strength. The category takes into consideration the local stress concentration at the detail, the size and shape of the maximum acceptable discontinuity, the loading condition, metallurgical effects, residual stresses, fatigue crack shapes, the welding procedure, and any post-welding improvement.

3.2 BASIC PRINCIPLES

3.2.1 General

- 1-** The differences in fatigue strength between grades of steel are small and may be neglected.
- 2-** The differences in fatigue damage between stress cycles having different values of mean stress but the same value of stress range may be neglected.
- 3-** Cracks generally occur at welds or at stress concentration due to sudden changes of cross-sections. Very significant improvements in fatigue strength can be achieved by reducing the severity of stress concentrations at such points.
- 4-** When fatigue influences the design of a structure, details should be precisely defined by the designer and should not be amended in any way without the designer's prior approval. Similarly, no attachments or cutouts should be added to any part of the structure without notifying the designer.
- 5-** Structures, in which the failure of a single element could result in a collapse or catastrophic failure, should receive special attention when fatigue cracks are a possibility. In such cases, the allowable stress ranges shall be limited to 0.8 times the values given in Table 3.2 or in Figure 3.1.
- 6-** Slotted holes shall not be used in bolted connections for members subjected to fatigue.

3.2.2 Factors Affecting Fatigue Strength

The fatigue strength of the structural elements depends upon:

- 1- The applied stress range.
- 2- The detail category of the particular structural component or joint design.
- 3- The number of stress cycles.

3.2.3 Fatigue Loads

- 1- Cranes: The fatigue load used to calculate the stress range is the full travelling crane load including impact.
- 2- Roadway Bridges: The fatigue loads used to calculate the stress range are 60% of the standard design live loads including the corresponding dynamic effect.
- 3- Railway Bridges: The fatigue loads used to calculate the stress range are the full standard design live loads.

For bridges carrying both trucks and trains, the fatigue load is the combined effect of the full railway live load and 60% of the traffic live loads.

3.2.4 Fatigue Assessment Procedure

- i- The fatigue assessment procedure should verify that the effect of the applied stress cycles expected in the design life of the structure is less than its fatigue strength.
- ii- The effect of applied stress cycles is characterized by the maximum stress range (F_{sra}). The maximum stress range can be computed from the applied fatigue loads using an elastic method of analysis. The fatigue loads should be positioned to give the maximum straining actions at the studied detail. In some structures such as bridges and



cranes, consideration should be given to possible changes in usage such as the growth of traffic, changes in the most severe loading, etc.

iii- In non-welded details or stress relieved welded details subjected to stress reversals, the effective stress range to be used in the fatigue assessment shall be determined by adding the tensile portion of the stress range and 60% of the compressive portion of the stress range. In welded details subjected to stress reversals, the stress range to be used in the fatigue assessment is the greatest algebraic difference between maximum stresses.

iv- The fatigue strength of a structural part is characterized by the allowable stress range (F_{sr}) which is obtained from Table 3.2 or Figure 3.1 for the specified number of constant cycles and the particular detail category.

v- The number of constant stress cycles to be endured by the structure during its design life is given in Table 3.1a for roadway bridges, Table 3.1b for railway bridges, and Table 3.1c for crane structures. The number of cycles given in Tables 3.1a to 3.1c is subject to modifications according to the competent authority requirements.

vi- In detailing highway bridges for design lives greater than 50 years, the fatigue loads should be increased by a magnification factor, M , given by the following Table:

No. of Years	50	80	100	120
Magnification Factor, M	1.00	1.10	1.15	1.20

vii- Each structural element has a particular detail category as shown in Table 3.3. The classification is divided into four parts which correspond to the following four basic groups:

Group 1: non-welded details, plain materials, and bolted plates.

Group 2: welded structural elements, with or without attachments.

Group 3: fasteners (welds and bolts).

Group 4: orthotropic deck bridge details.

viii- When subjected to tensile fatigue loading, the allowable stress range for High Strength Bolts friction type shall not exceed the following values:

Number of Cycles (N)	Allowable Stress Range F_{sr} (t/cm ²)	
	Bolts Grade (8.8)	Bolts Grade (10.9)
$N \leq 20,000$	2.9	3.6
$20,000 < N \leq 500,000$	2.6	3.2
$500,000 < N$	2.0	2.5

Table (3.1a) Number of Loading Cycles – Roadway Bridges

Type of Road	ADTT *	Number of Constant Stress Cycles (N)	
		Longitudinal Members	Transverse Members
Major Highways and Heavily Travelled Main Roads	≥ 2500	2,000,000	Over 2,000,000
	< 2500	500,000	2,000,000
Local Roads and Streets		100,000	500,000

* ADTT = Average Daily Truck Traffic for 50 years design life

Table (3.1b) Number of Loading Cycles – Railway Bridges

Member Description	Span Length (L) (m)	Number of Constant Stress Cycles (N)
Class I Longitudinal flexural members and their connections, or truss chord members including end posts and their connections.	$L > 30$	500,000
	$30 \geq L \geq 10$	2,000,000
	$L < 10$	Over 2,000,000
Class II Truss web members and their connections except as listed in class III	Two tracks loaded	200,000
	One track loaded	500,000
Class III Transverse floor beams and their connections or truss verticals and sub- diagonals which carry floor beam reactions only and their connections	Two tracks loaded	500,000
	One track loaded	over 2,000,000

Table (3.1c) Number of Loading Cycles – Crane Structures

ADA *	Field of Application	Number of Constant Stress Cycles (N)
5	Occasional use	100,000
25	Regular use with intermittent operation	500,000
100	Regular use with continuous operation	2,000,000
> 100	Severe continuous operation	According to actual use

*

ADA = Average Daily Application for 50 years design life

Table (3.2) Allowable Stress Range (F_{sr}) for Number of Constant Stress Cycles (N)

Detail Category \ N	F_{sr} (t/cm ²)			
	100,000	500,000	2,000,000	Over 2,000,000
A	4.30	2.52	1.68	1.68
B	3.42	2.00	1.26	1.12
B'	2.77	1.62	1.02	0.85
C	2.48	1.45	0.91	0.70
D	1.92	1.12	0.71	0.49
E	1.53	0.89	0.56	0.32
E'	1.11	0.65	0.41	0.18
F	0.72	0.52	0.40	0.36

Table 3.2 and Figure 3.1 are based on the following Equation:

$$\log N = \log a - m \log F_{sr}$$

Where :

- N** = The number of constant stress cycles
 F_{sr} = The allowable stress range
m and log a = constants that depend on the detail category as follows:

Detail Category	m	Log a
A	3	6.901
B	3	6.601
B'	3	6.329
C	3	6.181
D	3	5.851
E	3	5.551
E'	3	5.131
F	5	4.286

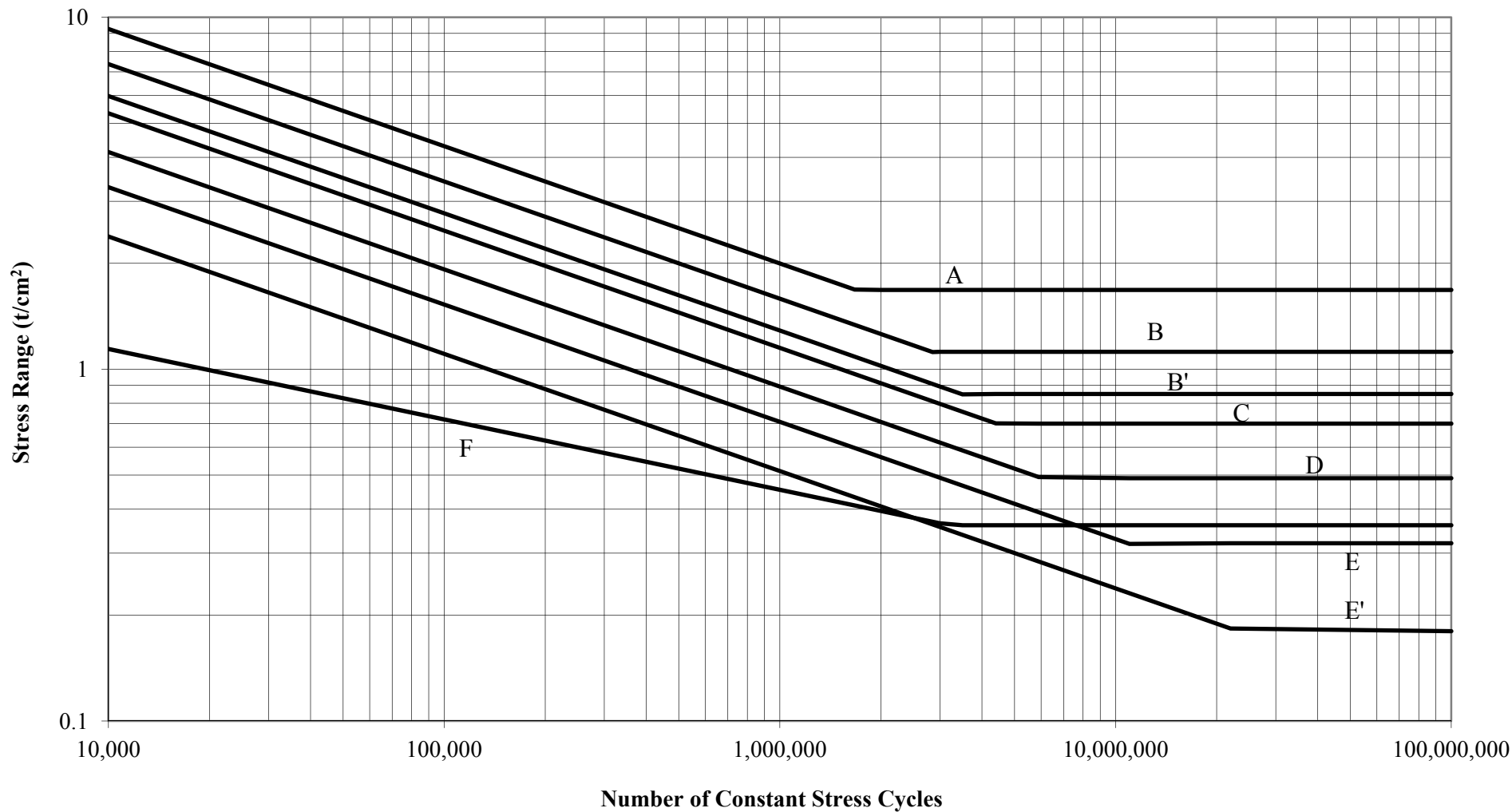
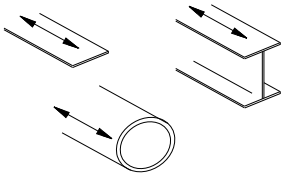
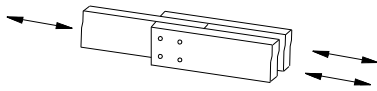

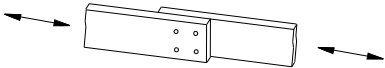
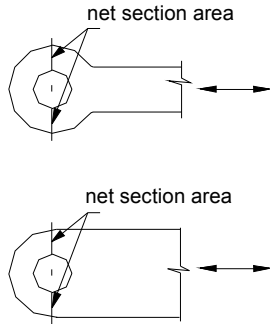


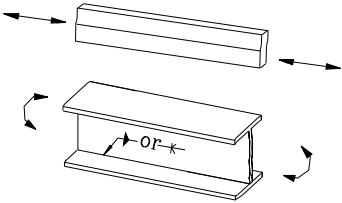
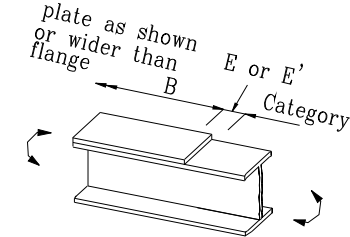
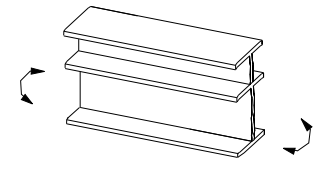
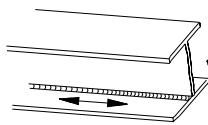

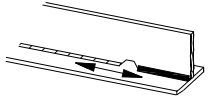
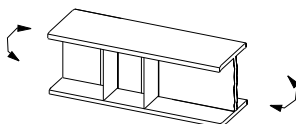
Fig. 3.1. Stress Range Versus Number of Constant Stress Cycles

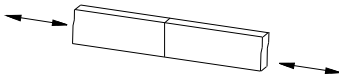
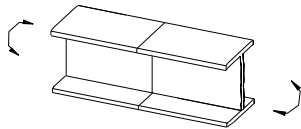
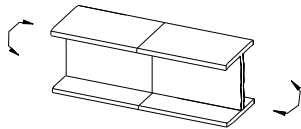
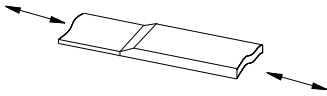
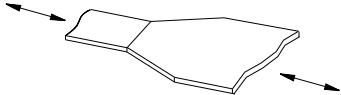
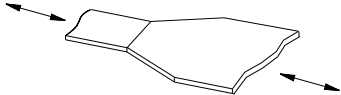
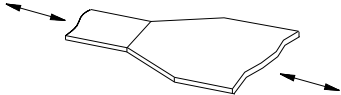
Table 4.3. Classification of details

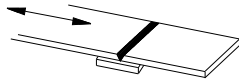
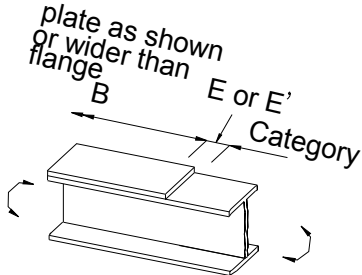
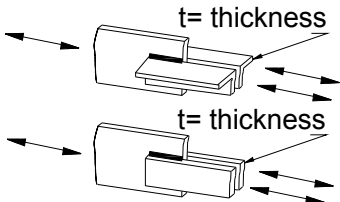
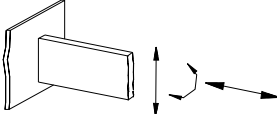
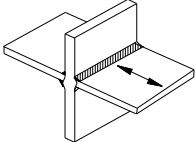
Group 1: Non-Welded Details

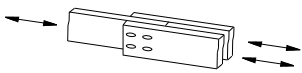
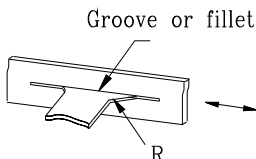
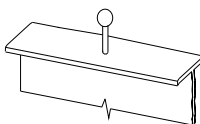
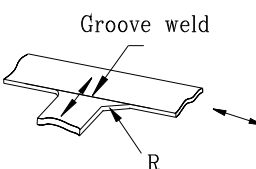
Description	Illustration	Class
1.1. Base metal with rolled or cleaned surfaces; flame cut edges with a surface roughness less than $25 \mu\text{m}$		A
1.2. Base metal with sheared or flame cut edges with a surface roughness less than $50 \mu\text{m}$		B
2.1. Base metal at gross section of high strength bolted slip resistant (friction) connections, except axially loaded joints which induce out of plane bending in connected material.		B
2.2. Base metal at net section of fully tensioned high strength bolted bearing type connections		B'
2.3. Base metal at net section of other mechanically fastened joints (ordinary bolts & rivets).		D
3. Base metal at net section of eye-bar head or pin plate.		E

Group 2: Welded Structural Elements

Description	Illustration	Class
4.1. Base metal in members without attachments, built up plates or shapes connected by continuous full penetration groove welds or by continuous fillet welds carried out from both sides without start stop positions parallel to the direction of applied stress.		B
4.2. Same as (4.1.) with welds having stop - start positions.		B'
4.3. Base metal in members without attachments, built-up plates or shapes connected by continuous full penetration groove welds with backing bars not removed, or by partial penetration groove welds parallel to the direction of applied stress.		B'
5. Base metal at continuous manual longitudinal fillet or full penetration groove welds carried out from one side only. A good fit between flange and web plates is essential and a weld preparation at the web edge such that the root face is adequate for the achievement of regular root penetration.		C
6. Base metal at zones of intermittent longitudinal welds with gap ratio $g/h < 2.5$		D
7. Base metal at zones containing copes in longitudinally welded T-joints.		D
8. Base metal at toe of welds on girder webs or flanges adjacent to welded transverse stiffeners.		C

Description	Illustration	Class
<p>9.1. Base metal and weld metal at full penetration groove welded splices (weld made from both sides) of parts of similar cross sections ground flush, with grinding in the direction of applied stress and weld soundness established by radiographic or ultrasonic inspection.</p>		B
<p>9.2. Same as (9.1.) but with reinforcement not removed and less than 0.10 of weld width.</p>		C
<p>9.3. Same as (9.2.) with reinforcement more than 0.10 of weld width.</p>		D
<p>10.1. Base metal and weld metal at full penetration groove welded splices (weld made from both sides) at transitions in width or thickness, with welds ground to provide slopes no steeper than 1 to 2.5 with grinding in the direction of applied stress, and with weld soundness established by radiographic or ultrasonic inspection.</p>		B'
<p>10.2. Same as (10.1.) but with reinforcement not removed and less than 0.10 of weld width.</p>		C
<p>10.3. Same as (10.2.) with slopes more than 1 to 2.5</p>		D
<p>10.4. Same as (10.1.) to (10.3.) but with welds made from one side only.</p>		E'

Description	Illustration	Class
11.1. Base metal and weld metal at transverse full penetration groove welded splices on a backing bar. The end of the fillet weld of the backing strip is more than 10 mm from the edges of the stressed plate		D
11.2. Same as (11.1) with the fillet weld less than 10 mm from the edges of the stressed plate.		E
12.1. Base metal at ends of partial length welded cover plates narrower than the flange having square or tapered ends, with or without welds across the ends or wider than the flange with welds at the ends. Flange thickness ≤ 20 mm		E
Flange thickness > 20 mm		E'
12.2 Base metal at ends of partial length welded cover plates wider than the flange without end welds.		E'
13. Base metal at axially loaded members with fillet welded connections. $t \leq 25$ mm		E
$t > 25$ mm		E'
14. Base metal at members connected with transverse fillet welds.		C
15.1. Base metal at full penetration weld in cruciform joints made of a special quality weld.		D
15.2. Same as (15.1) with partial penetration or fillet welds of normal quality.		E'


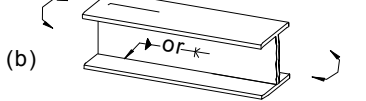
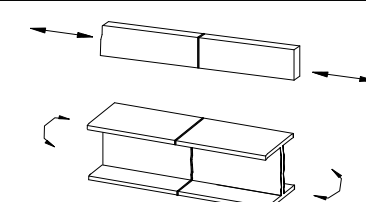
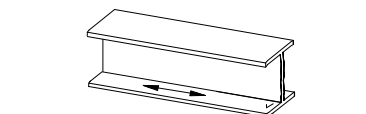
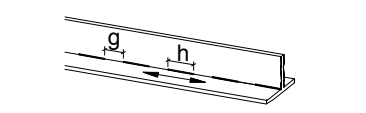
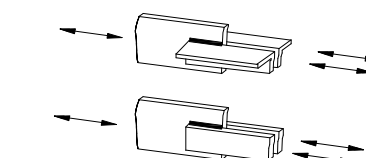
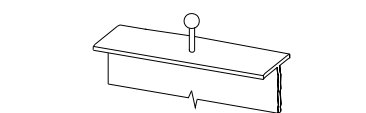
Description	Illustration	Class
16. Base metal at plug or slot welds.		E
17. Base metal and attachment at fillet welds or partial penetration groove welds with main material subjected to longitudinal loading and weld termination ground smooth R > 50 mm		D
R < 50 mm		E
18. Base metal at stud- type shear connector attached by fillet weld or automatic end weld.		C
19.1. Base metal at details attached by full penetration groove welds subject to longitudinal loading with weld termination ground smooth. Weld soundness established by radiographic or ultrasonic inspection R > 610 mm		B
610 mm > R > 150 mm		C
150 mm > R > 50 mm		D
R < 50 mm		E
19.2. Same as (19.1.) with transverse loading, equal thickness, and reinforcement removed. R > 610 mm		B
610 mm > R > 150 mm	C	
150 mm > R > 50 mm	D	
R < 50 mm	E	



Description	Illustration	Class
19.3. Same as (19.2.) but reinforcement not removed $R > 610$ mm		C
610 mm $> R > 50$ mm		C
150 mm $> R > 50$ mm		D
$R > 50$ mm		E
19.4. Same as (19.2.) but with unequal thickness		D
$R > 50$ mm		E
$R < 50$ mm		E
19.5. Same as (19.4.) but with reinforcement not removed and for all R	E	
20. Base metal at detail attached by full penetration groove welds subject to longitudinal loading $50\text{-mm} < a < 12t$ or 100 mm		D
$a > 12t$ or 100 mm ($t < 25$ mm)		E
$a > 12t$ or 100 mm ($t > 25$ mm)		E'
21. Base metal at detail attached by fillet welds or partial penetration groove welds subject to longitudinal loading $a < 50$ mm		C
50 mm $< a < 12t$ or 100 mm		D
$a > 12t$ or 100 mm ($t < 25$ mm)		E
$a > 12t$ or 100 mm ($t > 25$ mm)		E'



Group 3: Fasteners (Welds and bolts)

Description	Illustration	Class
22.1. Weld metal of full penetration groove welds parallel to the direction of applied stress (weld from both sides)	(a)  (b) 	B
22.2. Same as (22.1.) but with weld from one side only.		C
22.3. Weld metal of partial penetration transverse groove weld based on the effective throat area of the weld.		F
23.1 Weld metal of continuous manual or automatic longitudinal fillet welds transmitting a continuous shear flow.		D
23.2 Weld metal of intermittent longitudinal fillet welds transmitting a continuous shear flow.		E
23.3 Weld metal at fillet welded lap joints.		E'
24. Transversally loaded fillet welds.		E'
25. Shear on plug or slot welds.		F
26. Shear stress on nominal area of stud-type shear connectors.(Failure in the weld or heat affected zone.)		F
27.1. High strength bolts in single or double shear (fitted bolt of bearing type).		C
27.2. Rivets and ordinary bolts in shear.		D
28. Bolts and threaded rods in tension (on net area)		F

Group 4: Orthotropic Deck Bridges

Description	Illustration	Class
29.1. Base metal at continuous longitudinal rib with or without additional cutout in cross girder. (Bending stress range in the rib) $t \leq 12\text{mm}$		C
29.2. Same as (29.1.) $t > 12\text{mm}$		D
30. Base metal at separate longitudinal ribs on each side of the cross girder. (Bending stress range in the rib)		E'
31. Base metal at rib joints made of full penetration weld with backing plate. (Bending stress range in the rib)		D
32.1. Base metal at rib joints made of full penetration weld without backing plate. All welds ground flush to plate surface in the direction of stress. Slope of thickness transition < 1:4. (Bending stress range in the rib)		B'
32.2. Same as (32.1.) with weld reinforcement ≤ 0.2		C
33. Base metal at connection of continuous longitudinal rib to cross girder. (Equivalent stress range in the cross girder web).		E'
34.1. Weld metal at full penetration weld connecting deck plate to rib section.		D
34.2. Weld metal at fillet weld connecting deck plate to rib section.		E'



CHAPTER 4

STABILITY AND SLENDERNESS RATIOS

4.1 GENERAL

4.1.1 General stability shall be checked for the structure as a whole and for each individual member.

4.1.2 The slenderness ratio of a member shall be taken as:

$$\lambda = \frac{K \cdot L}{r} \quad \dots\dots\dots 4.1$$

where;

- λ = The slenderness ratio,
- K = The buckling length factor:
For a compression member, K depends on the rotational restraint at the member ends and the means available to resist lateral movements.
For tension members, K = 1.0
- L = The unsupported length for tension or compression members.
- r = The radius of gyration corresponding to the member's effective buckling length (KL).

4.2 MAXIMUM SLENDERNESS RATIOS λ_{max}

4.2.1 The slenderness ratio of a compression member, shall not exceed λ_{max} of Table 4.1

Table(4.1) Maximum Slenderness Ratio for Compression Members

Member	λ_{max}
Buildings:	
Compression members	180
Bracing systems and secondary members	200
Bridges:	
Compression members in railway bridges	90
Compression members in roadway bridges	110
Bracing systems	140

4.2.2 The slenderness ratio of a tension member shall not exceed λ_{\max} of Table 4.2

Table (4.2) Maximum Slenderness Ratio for Tension Members *

Member	λ_{\max}
Buildings:	
Tension members	300
Bridges:	
Tension members in railway bridges	160
Tension members in roadway bridges	180
Vertical hangers	300
Bracing systems	200

* The use of rods and cables in bracing systems or as a main tension member is prohibited in this code.

4.3 BUCKLING FACTOR (K)

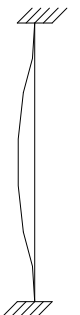
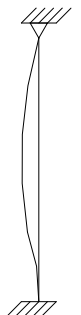
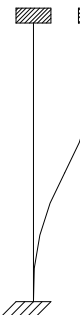
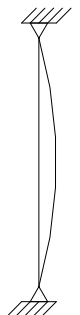
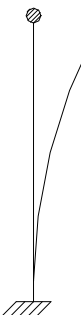





4.3.1 The recommended values for the buckling length factor (K - Equation 4.1) are given in Table 4.3 for members with well-defined (idealized) end conditions.

4.3.2 Trusses

4.3.2.1 The effective buckling length (KL) of a compression member in a truss is either obtained from Tables 4.4 and 4.5 for buildings and bridges respectively, or determined from an elastic critical buckling analysis of the truss.

4.3.2.2 For a simply supported truss, with laterally unsupported compression chords and with no cross-frames but with each end of the truss adequately restrained (Figure 4.1), the effective buckling length (KL), shall be taken equal to 0.75 of the truss span.

Table (4.3) Buckling Length Factor for Members with Well Defined End Conditions

BUCKLING MODE						
k	0.65	0.80	1.20	1.00	2.10	2.00
END CONDITIONS		ROTATION PREVENTED, TRANSLATION PREVENTED				
		ROTATION PERMITTED, TRANSLATION PREVENTED				
		ROTATION PREVENTED, TRANSLATION PERMITTED				
		ROTATION PERMITTED, TRANSLATION PERMITTED				

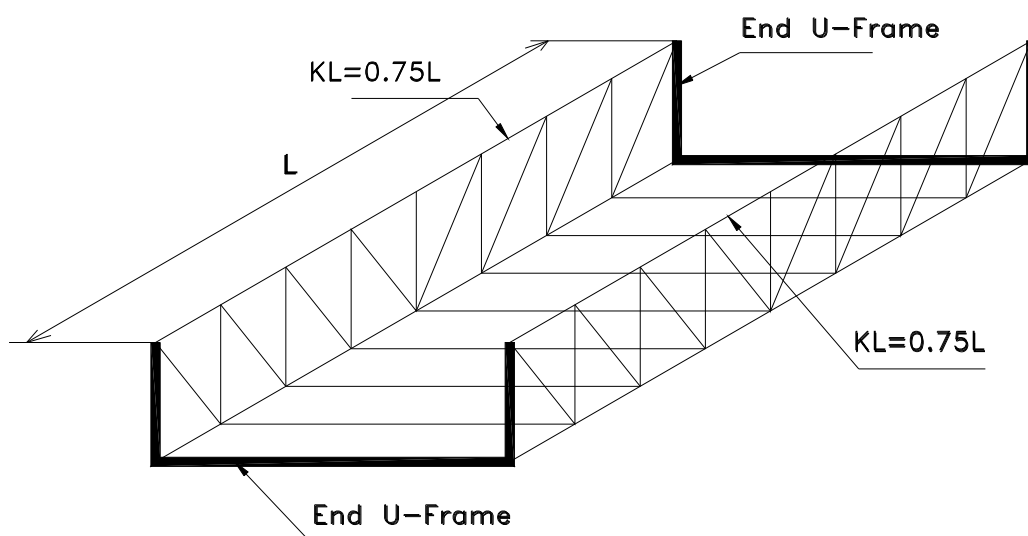


Figure (4.1) Truss with a Compression Member Laterally Unbraced



4.3.2.3 For a bridge truss where the compression chord is laterally restrained by U-frames composed of the cross girders and verticals of the trusses, the effective buckling length of the compression chord (l_b) is

$$l_b = 2.5 \cdot \sqrt[4]{E \cdot I_y \cdot a \cdot \delta} \geq a \dots\dots\dots 4.2$$

Where,

- E** = The Young's modulus (t/cm²).
- I_y** = The moment of inertia of the chord member about the Y-Y axis shown in Figure 4.2 (cm⁴).
- a** = The distance between the U-frames (cm).
- δ** = The flexibility of the U-frame: the lateral deflection near the mid-span at the level of the considered chord's centroid due to a unit load acting laterally at each chord connected to the U-frame. The unit load is applied only at the point at which δ is being calculated. The direction of each unit load shall produce a maximum value for δ (cm).

The U-frame is considered to be free and unconnected at all points except at each point of intersection between cross girder and vertical of the truss where this joint is considered to be rigidly connected.

In case of symmetrical U-frame with constant moment of inertia for each of the cross girder and the verticals through their own length, δ may be taken from:

$$\delta = \frac{d_1^3}{3EI_1} + \frac{d_2^2 B}{2EI_2} \dots\dots\dots 4.3$$

Where:

- d₁** = The distance from the centroid of the compression chord to the nearest face of the cross girder of the U-frame.

- d_2 = The distance from the centroid of the compression chord to the centroidal axis of the cross girder of the U-frame.
- I_1 = The second moment of area of the vertical member forming the arm of the U-frame about the axis of bending.
- I_2 = The second moment of area of the cross girder about the axis of bending
- B = The distance between centres of consecutive main girders connected by the U-frame.

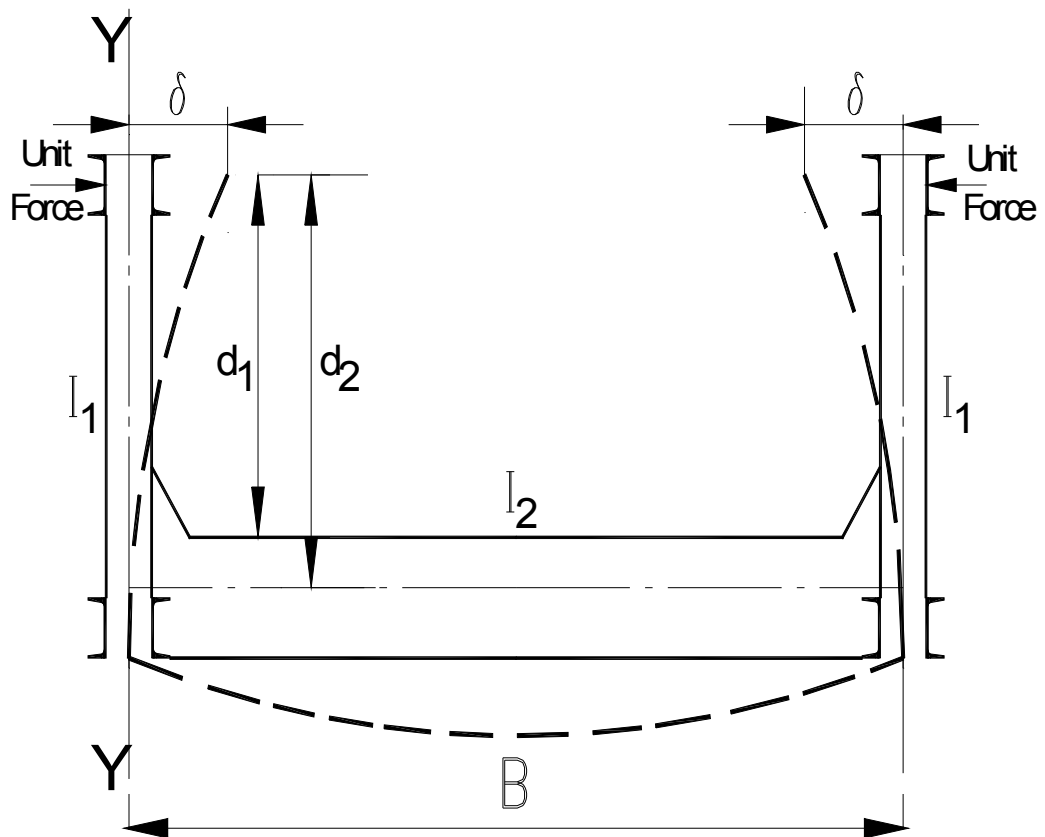


Figure (4.2) Lateral Restraint of Truss Chords by U-Frame

Table (4.4) Buckling Length of Compression Members in Buildings and in Bridge Bracing Systems

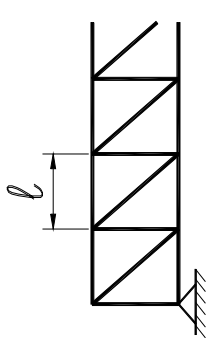
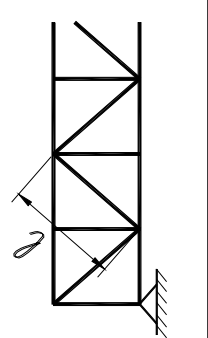
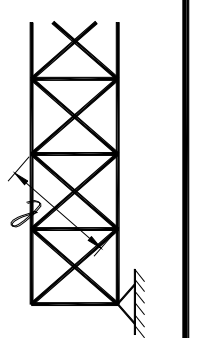
Member	In-Plane	Out-of-Plane	
		Compression Chord Effectively Braced	Compression Chord Unbraced
<p><u>Chords</u></p> 	l	l	0.75 span (Clause 4.3.2.2)
<p><u>Diagonals</u></p> <p>-Single Triangulated web system</p> 	l	l	$1.2 l$
<p>-Multiple Intersected web rectangular system adequately connected</p> 	$0.5 l$	$0.75 l$	l

Table (4.4) Buckling Length of Compression Members in Buildings and in Bridge Bracing Systems (Cont.)

Member	In-Plane	Out-of-Plane	
		Compression Chord Effectively Braced	Compression Chord Unbraced
<p>Diagonals</p> <ul style="list-style-type: none"> - Multiple Intersected web trapezoidal system adequately connected 	l	$0.8 l_d$	—
<ul style="list-style-type: none"> - K-system 	l	$1.2 l$	$1.5 l$
<p>Vertical members</p> <ul style="list-style-type: none"> - Single triangulated web system 	l	l	$1.2 l$
<ul style="list-style-type: none"> - K-intersected web system 	$0.5 l$	$(0.75 + 0.25 \frac{N_s}{N_L}) l$	$(0.90 + 0.30 \frac{N_s}{N_L}) l$

N_s = Smaller value of compression force

N_L = Larger value of compression force

Table (4.5) Buckling Length of Compression Members in Bridges

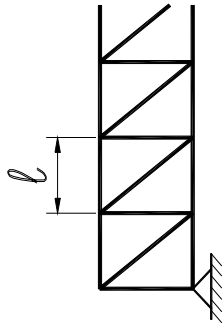
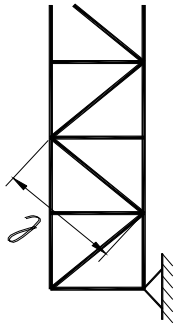
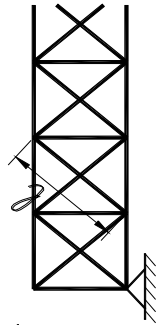
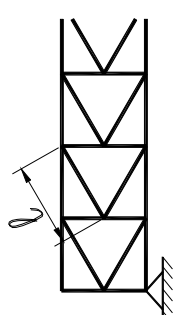
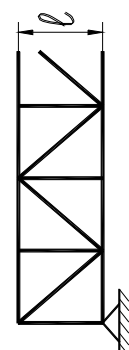
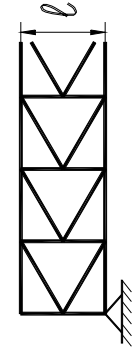
Member	In-Plane	Out-of-Plane	
		Compression Chord Effectively Braced	Compression Chord Unbraced
<p><u>Chords</u></p> 	0.85ℓ	0.85ℓ	<p>0.75 Span (Clause 4.3.2.2) or Equation 4.2 if using U-Frames</p>
<p><u>Diagonals</u></p> <p>-Single Triangulated web system</p> 	0.70ℓ	0.85ℓ	1.2ℓ
<p>-Multiple Intersected web rectangular system adequately connected</p> 	$0.85 \ell/2$	0.75ℓ	ℓ

Table (4.5) Buckling Length of Compression Members in Bridges (Cont.)

Member	In-Plane	Out-of-Plane	
		Compression Chord Effectively Braced	Compression Chord Unbraced
- K-system 	0.9 l	1.2 l	1.5 l
<u>Vertical members</u> -Single triangulated web system 	0.7 l	0.85 l	1.2 l
-K-intersected web system 	0.35 l	$(0.75+0.25 \frac{N_s}{N_L})l$	$(0.90+0.30 \frac{N_s}{N_L})l$

N_s = Smaller value of compression force

N_L = Larger value of compression force

4.3.3 Columns in Rigid Frames

4.3.3.1 The buckling factor (K) for a column or a beam-column in a rigid frame is obtained from the alignment charts given in Figure 4.3.

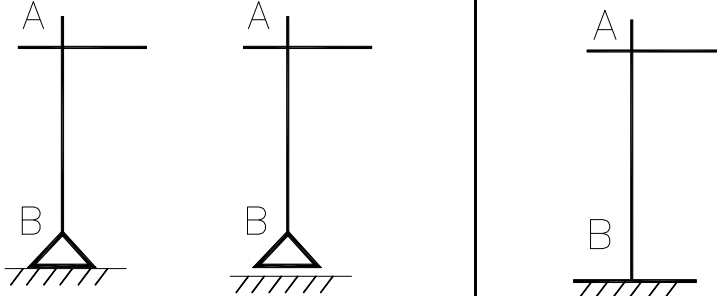
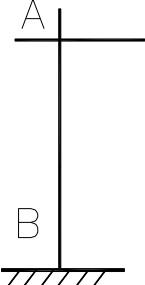
4.3.3.2 The alignment charts are function of the ratio of the moment of inertia to length of members (I/L). Conservative assumption is made that all columns in the portion of the frame under consideration reach their individual buckling loads simultaneously. The charts are based on a slope deflection analysis. In Figure 4.3, the two subscripts A and B refer to the points at the two ends of the column or beam-column under consideration, while G is defined by:

$$G = \frac{\sum (I/L) \text{ columns}}{\sum (I/L) \text{ girders}} \dots\dots\dots 4.4$$

Where, the Σ indicates a summation of (I/L) for all members rigidly connected to that joint (A or B) and laying in the plane in which buckling of the column is being considered. L is the unsupported length and I is the moment of inertia perpendicular to the plane of buckling of the columns and the beams.

4.3.3.3 For a column base connected to a footing or foundation by a frictionless hinge, G is theoretically infinite, but shall be taken as 10 in design practice. If the column base is rigidly attached to a properly designed footing, G theoretically approaches 0.0, but shall be taken as 1.0 in design practice (Table 4.6).

Table (4.6) G values for Columns with Special End Conditions

Column Base Condition		
G_B	$G_B = 10.0$	$G_B = 1.0$

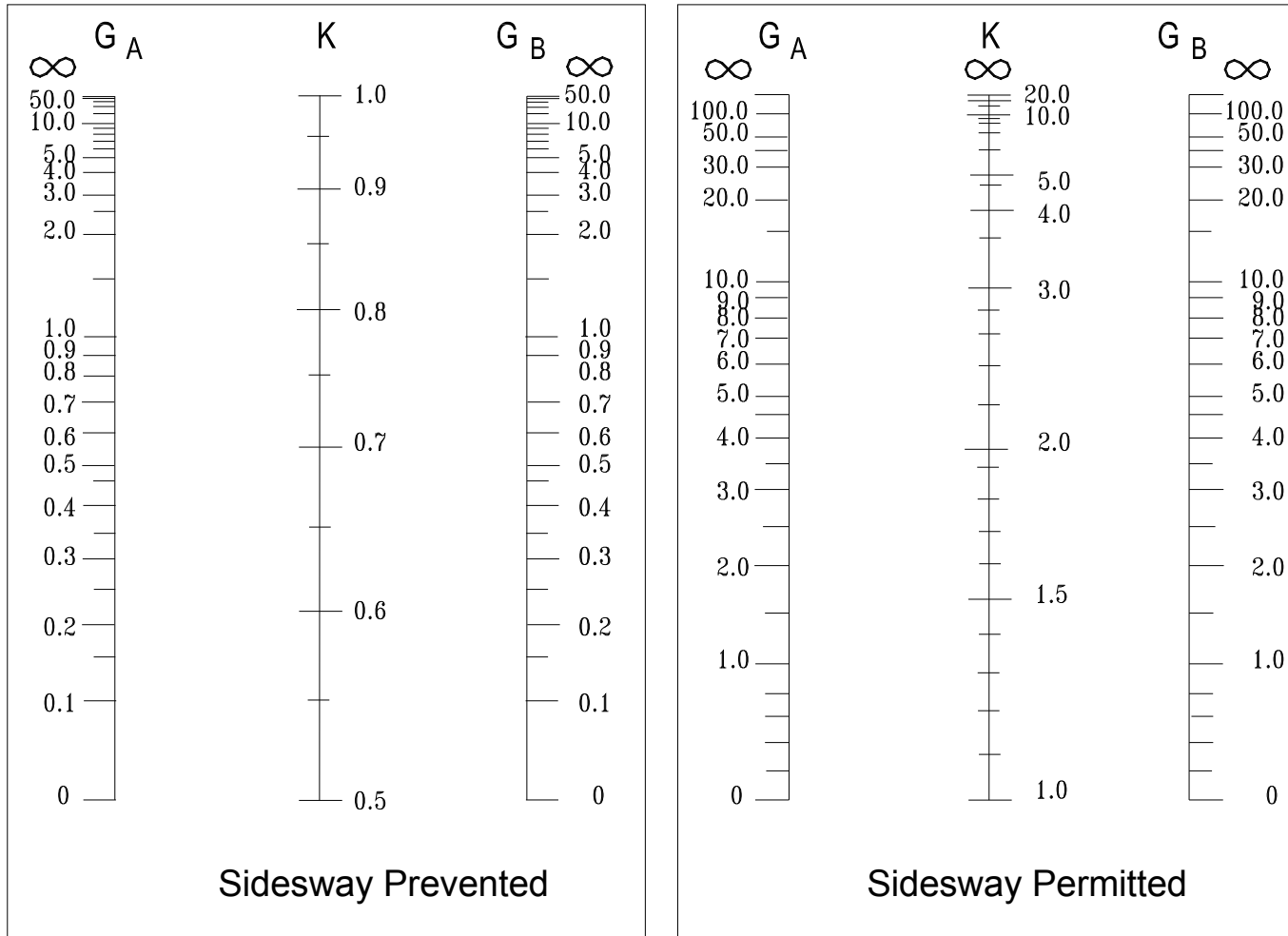
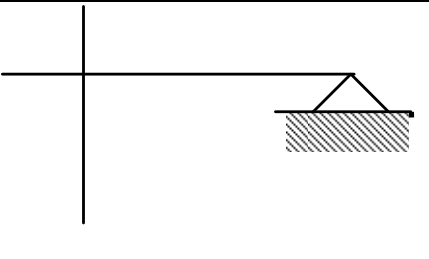
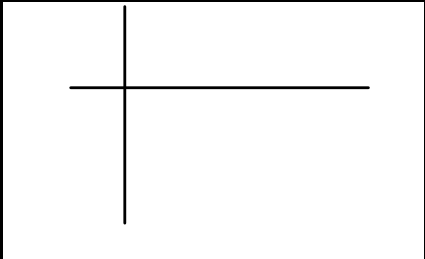


Figure (4.3) Alignment Charts for Buckling Length Factor (K) of Columns in Rigid Frames
 Figure (5.2) Alignment Charts for Effective Length of Columns in Rigid Frames .

4.3.3.4 For beams with the far end hinged, the beam stiffness $(I/L)_g$ is multiplied by a factor equals 1.5 for sidesway prevented and 0.5 for side sway permitted. For beams with the far end fixed the beam stiffness $(I/L)_g$ is multiplied by a factor of 2.0 for sidesway prevented and 0.67 for sidesway permitted (Table 4.7).

Table (4.7) Beams With Special End Conditions

Beam End Condition		
Sidesway prevented	$(I/L)_g \times 1.5$	$(I/L)_g \times 2.0$
Sidesway permitted	$(I/L)_g \times 0.5$	$(I/L)_g \times 0.67$

4.3.3.5 To account for the fact that a strong column (or column with low axial force) will brace a weak column (or column with high axial force) a modification for the K factor shall be considered as follows:

$$K'_i = \sqrt{\frac{\sum P_c}{P_{ci}} \frac{I_i}{\sum \frac{I_i}{K_i^2}}} \geq \sqrt{\frac{5}{8}} K_i \quad \dots\dots\dots 4.5$$

$$P_{ci} = A_i F_c$$

Where:

K'_i and K_i = The modified value and the value determined from the alignment charts for the buckling length factor respectively.

A_i and I_i = The cross sectional area and moment of inertia respectively of the considered column.

F_c = The allowable axial compressive stress.

- P_{ci} = The axial compressive strength of the i^{th} rigidly connected column.
- ΣP_c = The axial compressive strength of all columns in a storey.

4.3.4 Buckling Length of Compression Flange of Beams

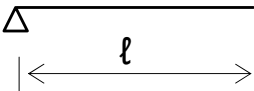
4.3.4.1 Simply Supported Beams

The effective buckling length of compression flange of simply supported beams shall be considered as follows :

4.3.4.1.1 Compression Flange With No Intermediate Lateral Support

The following Table 4.8 defines the effective buckling length of compression flange of simply supported beams having no intermediate supports

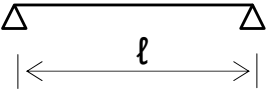
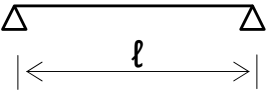
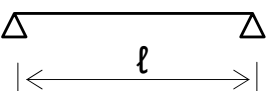
Table (4.8) Buckling Length of Compression Flange of Simply Supported Beams Having no Intermediate Lateral Supports

Compression Flange End Restraint Conditions	Beam Type	Buckling Length ($K\ell$)
End of compression flange unrestrained against lateral bending		ℓ
End of compression flange partially restrained against lateral bending	ℓ	0.85ℓ
End of compression flange fully restrained against lateral bending	ℓ	0.70ℓ

4.3.4.1.2 Compression Flange with Intermediate Lateral Support

Table 4.9 defines the effective buckling length of compression flange of simply supported beams having intermediate supports.

Table (4.9) Buckling Length of Compression Flange of Simply Supported Beams Having Intermediate Lateral Supports

Compression Flange End Restraint Conditions	Beam Type	Buckling Length ($K\ell$)
Beams where there is no bracing to support the compression flange laterally, but where cross beams and stiffeners forming U-frames provide lateral restraint		The effective buckling length is according to clause 4.3.2.3
Beams where there is an effective lateral bracing to the compression flange		Distance between centers of intersection of the bracing with the compression chord
Beams where the compression flange is unbraced but supported by rigid cross girders		Distance between centers of cross girders
Beams where the compression flange is supported by continuous reinforced concrete or steel deck, where the frictional or connection of the deck to the flange is capable to resist a lateral force of 2% of the flange force at the point of the maximum bending moment	ℓ	$K = 0$

4.3.4.2 Cantilever Beams with Intermediate Lateral Supports

The effective buckling length of compression flange of cantilever beams with intermediate lateral supports shall be similar to that of simply supported beams having lateral supports as given in Clause 4.3.4.1.2.

4.3.4.3 Cantilever Beams Without Intermediate Lateral Supports

The effective buckling length of compression flange of cantilever beams without intermediate lateral supports shall be according to Table 4.10. The loading condition (normal or destabilizing) is defined by the point of application of the load. Destabilizing load conditions exist when a load is applied to the top flange of a beam or cantilever and both the load and the flange are

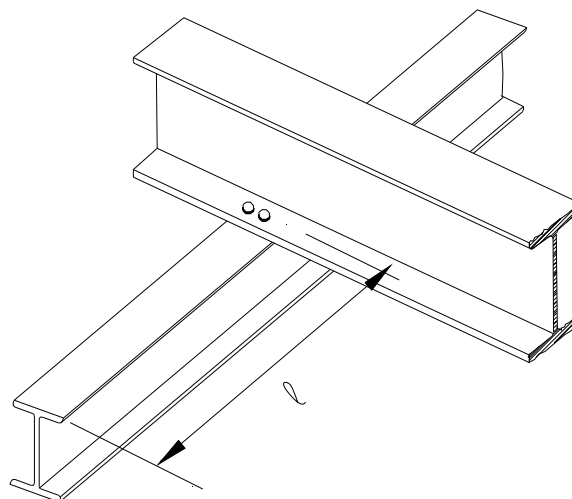


Figure (4.4) Continuous Cantilever with Lateral Restraint Only

Table (4.10) Effective Buckling Length of Compression Flange of Cantilever Beams Without Intermediate Supports

Restraint Conditions		Loading Conditions	
At support	At tip	Normal	Destabilizing
Continuous with lateral restraint only (see Fig. 4.4)	Free	3.0 l	7.5 l
	Laterally restrained on top flange only	2.7 l	7.5 l
	Torsionally restrained only	2.4 l	4.5 l
	Laterally and torsionally restrained	2.1 l	3.6 l
Continuous with lateral and torsional restraint (see Fig. 4.5)	Free	1.0 l	2.5 l
	Laterally restrained on top flange only	0.9 l	2.5 l
	Torsionally restrained only	0.8	1.5 l
	Laterally and torsionally restrained	0.7 l	1.2 l
Built-in laterally and torsionally (see Fig. 4.6)	Free	0.8 l	1.4 l
	Lateral restraint on top flange only	0.7 l	1.4 l
	Torsionally restrained only	0.6 l	0.6 l
	Laterally and torsionally restrained	0.5 l	0.5 l

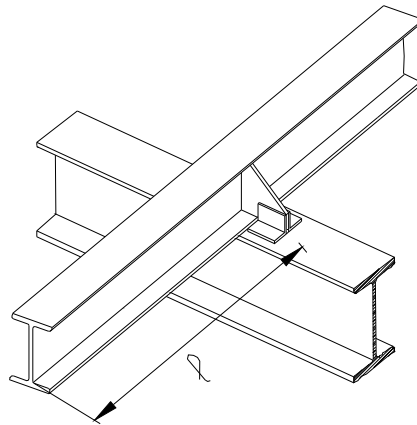


Figure (4.5) Continuous Cantilever with Lateral and Torsional Restraint

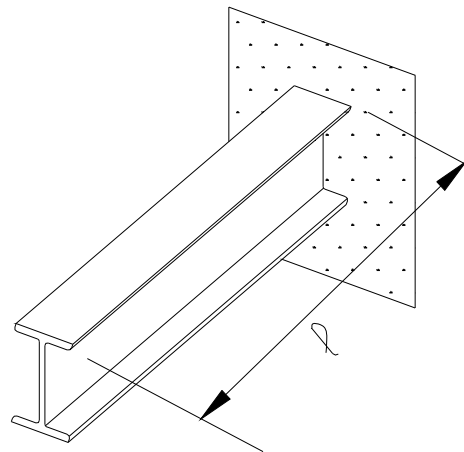


Figure (4.6) Cantilever Built-in Laterally and Torsionally

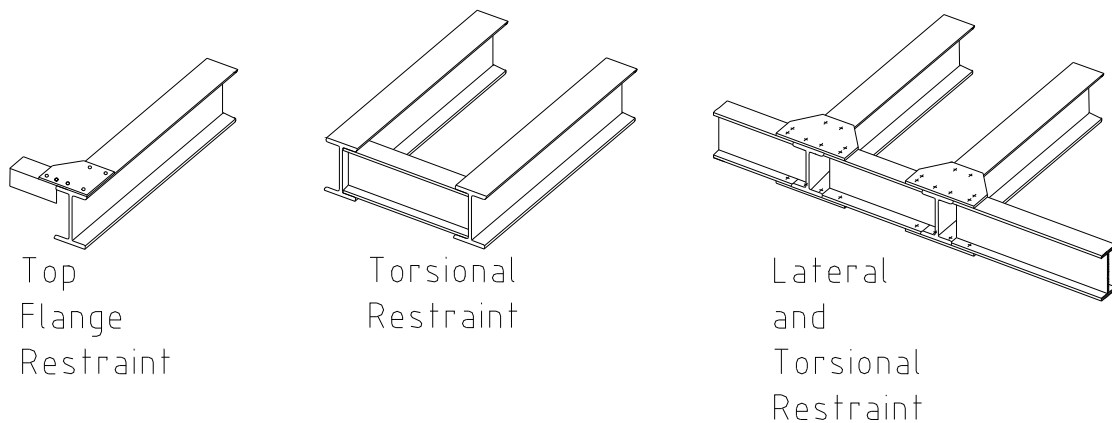


Figure (4.7) Type of Restraint Provided to the Cantilever Tip

CHAPTER 5

STRUCTURAL WELDING

The following Clauses regarding the welded connections are applicable to structures loaded with predominantly static loads, while for fatigue loadings refer to Chapter 3.

5.1 WELDABILITY AND STEEL PROPERTIES

“ Weldability “ is the capacity of a metal to be welded under the fabrication conditions imposed, into a specific, suitably designed structure, and to perform satisfactorily in the intended service.

Weldability is enhanced by low carbon, fine grain size and restricted (low) thickness. Conversely, it is reduced by high carbon, coarse grain, and heavy thickness. Table 5.1 abstracts the requirements covering weldability related variables.

5.2 STRUCTURAL WELDING PROCESS, WELDING POSITIONS AND ELECTRODES REQUIREMENTS

5.2.1 Welding Positions

The different welding positions are shown in Fig. 5.1 where:

- i- In the flat position weld metal can be deposited faster because gravity is working with the welder, so large electrodes and high currents can be used.
- ii- In the vertical and overhead positions, electrodes diameters below 4 mm (or at most 5 mm) are to be utilized otherwise weld metal runs down.
- iii- For arc welding the weld metal is deposited by the electromagnetic field, the welder is not limited to the flat or horizontal position.

Table (5.1) Requirements for Properties Affecting Weldability of Steel Shapes, Plates, and Bars

Grade of Steel	Nominal Values of Yield Stress F_y and Ultimate Strength F_u				Maximum Thickness of Statically Loaded Structural Elements (mm)	Charpy V-notch Test Temperature T_{cv}		
	Thickness t					T_{cv} Test Temperature (°C)	Minimum Energy J (joules) for Thickness (mm)	
	$t \leq 40$ mm		$40 \text{ mm} < t \leq 100$ mm				$> 10\text{mm} \leq 150\text{mm}$	$> 150\text{mm} \leq 250\text{mm}$
	F_y (t/cm ²)	F_u (t/cm ²)	F_y (t/cm ²)	F_u (t/cm ²)				
St 37	2.40	3.60	2.15	3.40	250	-20°	27	23
St 44	2.80	4.40	2.55	4.10	150	-20°	27	23
St 52	3.60	5.20	3.35	4.90	130			

iv- The designer should avoid whenever possible the overhead position, since it is the most difficult one.

v- Welds in the shop are usually in the flat position, where manipulating devices can be used to rotate the work in a flat position.

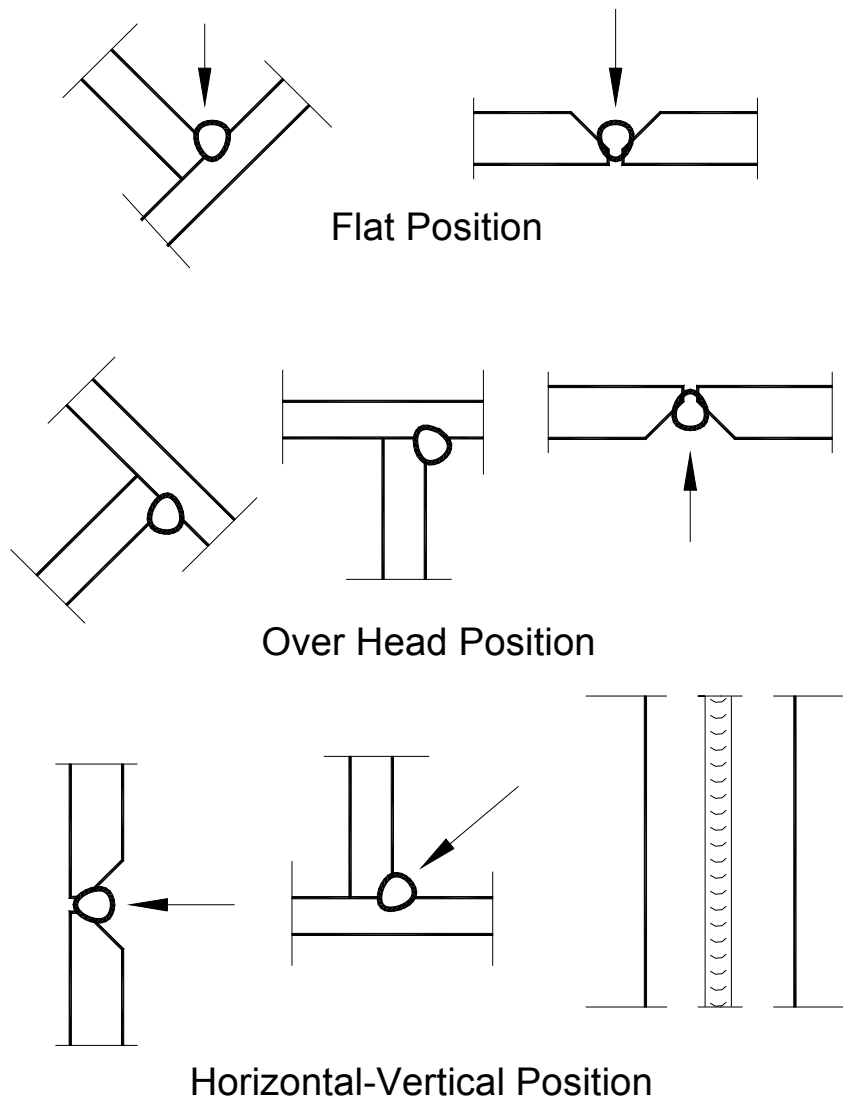


Figure (5.1) Welding Positions



5.2.2 Electrode Requirements

- i- The common size of electrodes for hand welding are 4 and 5 mm diameter. For the flat welding position 6 mm can be used.
- ii - 8 mm fillet weld size is the maximum size that can be made in one run with 5 mm coated electrodes.
- iii- For large sizes several runs of electrode in arc welding are to be made, while for gas processes any size can be made in one run.

The appropriate electrode type regarding the weld process as well as their yield and maximum tensile strength are given in Table 5.2.

The different welding processes and the important requirements for each is as outlined in Clause 5.2.3.

5.2.3 Welding Processes

Weldable structural steels meeting the requirements of Table 5.1 are welded by one of the following welding processes:

- Shielded Metal Arc Welding (S.M.A.W.)
- Submerged Arc Welding (S.A.W.)
- Gas Metal Arc Welding (G.M.A.W.)
- Flux Cored Arc Welding (F.C.A.W.)

The electrode properties matching the welding process as well as the appropriate welding position is as given in Table 5.2.

5.3 THERMAL CUTTING

Two cutting systems are available:

- i- Oxyfuel gas, which can cut almost any plate thickness used commercially.
- ii- Plasma arc which will cut almost up to about 40 mm thickness is much faster than Oxyfuel.

Table (5.2) Electrodes Used for Welding

Process	Electrode Strength *		Chemical Composition	Weld Position	Remarks
	Min. Yield Stress (t/cm ²)	Min. Tensile Strength (t/cm ²)			
Shield Metal Arc WELDING (S.M.A.W.)	3.45 – 6.75	4.25 – 7.6	<u>Electrode</u> : Low Carbon <u>Coating</u> : Aluminium, Silicon, other deoxidizers	All weld positions	Storage of electrodes in drying ovens near the points is a must.
Submerged Arc WELDING (S.A.W.)	3.45 – 6.75	4.25 – 8.95	<u>Electrode</u> : Medium Mn (1.0%) Nominal Carbon (0.12%) <u>Flux</u> : Finely powdered constituents glued together with silitalas.	Flat or horizontal weld position	-Fluxes must be kept in storage. - usually used in shop.
Gas Metal Arc WELDING (G.M.A.W.)	4.15 – 6.75	4.95 – 7.6	<u>Electrode</u> : Uncoated mild steel, dioxidized carbon manganese steel <u>Shielding Gas</u> : 75% Argon + 25% CO ₂ or 10% CO ₂	Flat or horizontal weld position	CO ₂ is the least shielding used in buildings and bridges.
Flux Cored Arc WELDING (F.C.A.W.)	3.45 – 6.75	4.25 – 8.6	<u>Electrode</u> : Low Carbon (0.05% Max.) <u>Flux</u> : Filled inside the electrode core (Self Shielded)	All weld positions	Useful for field welding in severe cold weather conditions.

* The minimum stress depends on type of electr



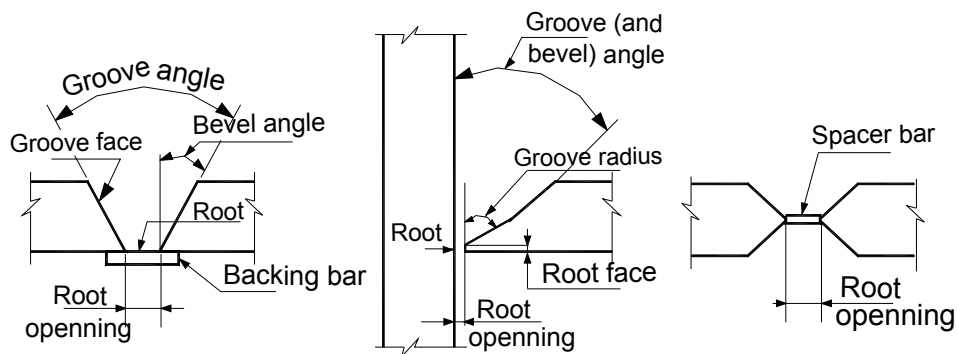
5.4 DISTORTION

Non- uniform rate of cooling after welding cause shrinkage which may cause distortion in the welded steel elements. In order to minimize distortion the following recommendations are to be taken into consideration.

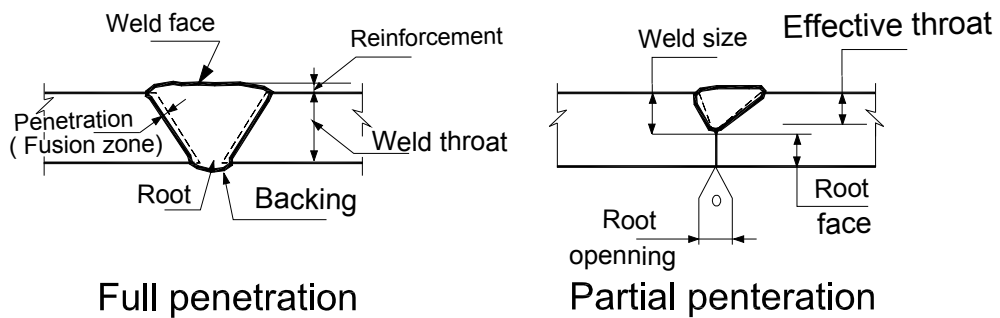
- i- Use the minimum weld metal no larger than is necessary to achieve the design strength.
- ii- Use symmetrical simultaneous welds.
- iii- Use minimum preheat. The rate of preheating must be slow and uniform, it is desirable to maintain the preheat temperature during the whole welding process.
- iv- For welds requiring more than one pass of welding, the interpass temperature is to be maintained to the temperature of the deposited welds when the next pass is begun.
- v- Use intermittent staggered welds.
- vi- Use clamps, jigs, etc., this forces weld metal to stretch as it cools.

5.5 DESIGN, STRENGTH AND LIMITATIONS OF BUTT (GROOVE) WELDED CONNECTIONS

5.5.1 Nomenclature Of The Common Terms

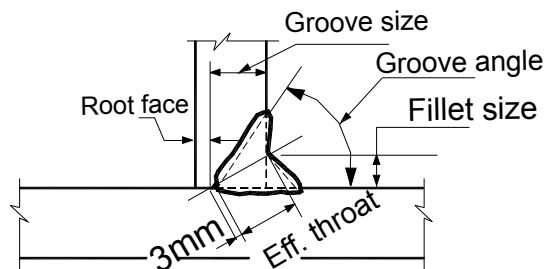


Preparation



Full penetration

Partial penetration



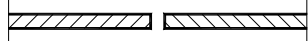


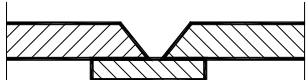
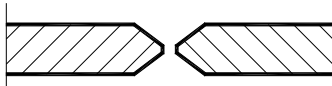
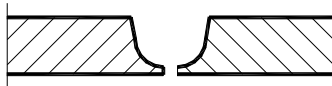
Partial penetration
(When reinforcing fillet
is specified)

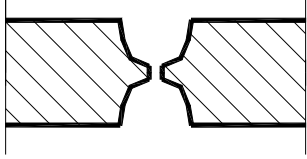
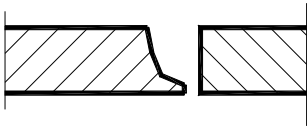
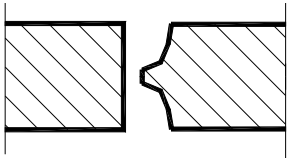
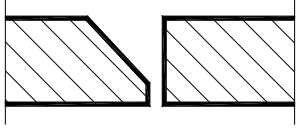
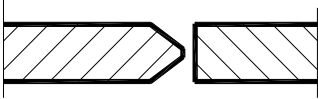
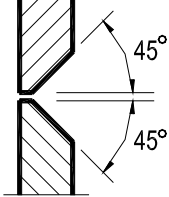
Figure (5.2) Butt (Groove) Weld Nomenclature

5.5.2 Different Types Of Groove (Butt) Welds

Table 5.3 shows the different types of groove (butt) welds classified according to their particular shape and named according to their specific edge penetration requirement.

Table (5.3) Types of Groove Butt Welding

<p>1. </p> <p><u>Square - Butt</u></p> <ul style="list-style-type: none"> • <u>Welded from one side:</u> up to 1.5 mm thick-no gap. • <u>Welded from both sides using Normal Electrodes :</u> up to 3 mm. thick-no gap. up to 5 mm. thick-take 1.5 mm gap. • <u>Welded from both sides using deep penetration electrodes:</u> up to 16 mm. -no gap. 	<p>2. </p> <p><u>Square Butt with Backing Bar</u></p> <ul style="list-style-type: none"> • <u>Normal Electrodes :</u> up to 5 mm. thick. 5mm gap. up to 13mm. thick. 8mm gap. • <u>Deep Penetration Electrodes :</u> up to 13mm. thick. 6mm gap.
<p>3. </p> <p><u>Single "V" Butt Weld</u></p> <ul style="list-style-type: none"> • <u>Included Angle :</u> 60° for flat position . 70° for vertical position . 80° for over head position . • <u>Root Thickness:</u> 0-3 mm . • Thickness up to 25 mm . • Gap 1.5 mm - 3 mm . 	<p>4. </p> <p><u>Single "V" Butt Weld With Backing Bar</u></p> <ul style="list-style-type: none"> • Included angles as(3). • Gap 3 mm. - 5 mm . • Thickness up to 25 mm .
<p>5. </p> <p><u>Double "V" Butt Weld</u></p> <ul style="list-style-type: none"> • Included angle gap and root thickness as(3) • Thickness 13 mm. - 50 mm. 	<p>6. </p> <p><u>Single "U" Butt Weld</u></p> <ul style="list-style-type: none"> • Included angle 20° - 40° • Gap 3 mm. - 5 mm . • Root thickness 3mm.-5mm. • Root radius 3mm.-10mm. • Thickness 25mm.-50mm.

<p>7. </p> <p><u>Double "U" Butt Weld</u></p> <ul style="list-style-type: none"> • Dimensions as(6). • Thickness 38 mm. upwards. 	<p>8. </p> <p><u>Single "J" Butt Weld</u></p> <ul style="list-style-type: none"> • Included angle $20^{\circ} - 30^{\circ}$. • Gap 3mm. - 5mm. • Root thickness 3mm.-5mm. • Root radius 5mm.-10mm. • Thickness 25mm - 50mm.
<p>9. </p> <p><u>Double "J" Butt Weld :</u></p> <ul style="list-style-type: none"> • Dimensions as(8). • Thickness 38 mm upwards . 	<p>10. </p> <p><u>Single Bevel Butt Weld</u></p> <ul style="list-style-type: none"> • Included angle $45^{\circ} - 50^{\circ}$. • Gap 3 mm. - 6 mm. • Root thickness 1.5mm-3mm. • Thickness up to 25 mm.
<p>11. </p> <p><u>Double Bevel Butt Weld</u></p> <ul style="list-style-type: none"> • Dimensions as 10 . • Thickness 25 mm. upwards . 	<p>12. </p> <p><u>Double Bevel Butt Weld</u></p> <ul style="list-style-type: none"> • Angles as shown . • Gap 1.5 mm - 3 mm . • Root thickness 1.5mm-3mm. • Thickness up to 38 mm.



Regarding the advantages, the economy, and the defects of each type, the following remarks are to be considered:

i- Double – bevel, double – vee, double J and double- V groove welds are more economical than single welds of the same type because of less contained volume.

ii- Bevel or Vee grooves can be flame cut and therefore are less expensive than J and V grooves which require planning or arc- air gouging.

iii- Single V welding is achieved from one side, it is difficult to prevent distortion, this type is usually economical over 25mm thickness.

iv- Single U welding is achieved from one side, the distortion is less than the single – Vee and is not economical under 19 mm thickness.

v- Double –Vee is a balanced welding with reduced distortion, requires reversals and is not recommended below 38 mm thickness.

vi- Double – U is a balanced welding with reduced distortion, requires reversals and is not recommended below 38mm thickness.

vii- Groove welds joining plates of different thicknesses shall preferably be made with a gradual thickness change not exceeding 1:4 as shown in Fig. 5.3a. for tension members. In compression members there is no need for a gradual thickness transition. The difference in thickness may be balanced by a slope in the weld metal rather than machining the parent metal as shown in Fig. 5.3b.

viii- Tee-Groove welds are accepted even if they are not completely welded achieving a partial penetration groove weld if the total weld thickness is greater than the parent metal thickness, see Fig.5.3c.

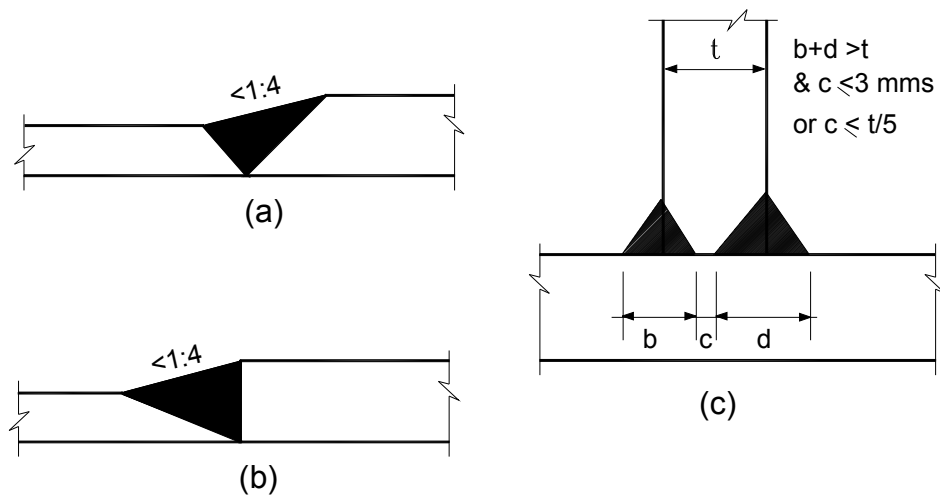


Figure (5.3) Groove Welds for Plates of Different Thicknesses

If these requirements are not fulfilled the Tee-Groove welds are to be analysed as being fillet welds according to the provisions of Section 5.6.

5.5.2.1 The Groove Weld Effective Area

The effective area is the product of the effective thickness dimension times the length of the weld. The effective thickness dimension of a full penetration groove weld is the thickness of the thinner part joined as shown in Fig. 5.4a.

Incomplete penetration groove welds and unsealed groove welds are not recommended, but when it is impossible to avoid their use, the effective thickness of weld is taken as the sum of the actual penetrated depths as shown in Fig. 5.4b,c and d.

5.5.2.2 Strength Of Butt (Groove) Welds

The complete joint penetration groove weld is of the same strength on the effective area as the piece being joined. For permissible stresses two values are considered; the first for good welds fulfilling the requirements of the specifications, the second value for excellent

welding where all welds are examined to guarantee the efficiency of the joint as given in Clause 5.9 :

- i- Permissible stresses for static loading are shown in Table 5.4 :

Table (5.4) Permissible Stresses for Static Loading in Groove (Butt) Welds

Type of Joint	Kind of Stress	Permissible Stress For	
		Good Weld	Excellent Weld

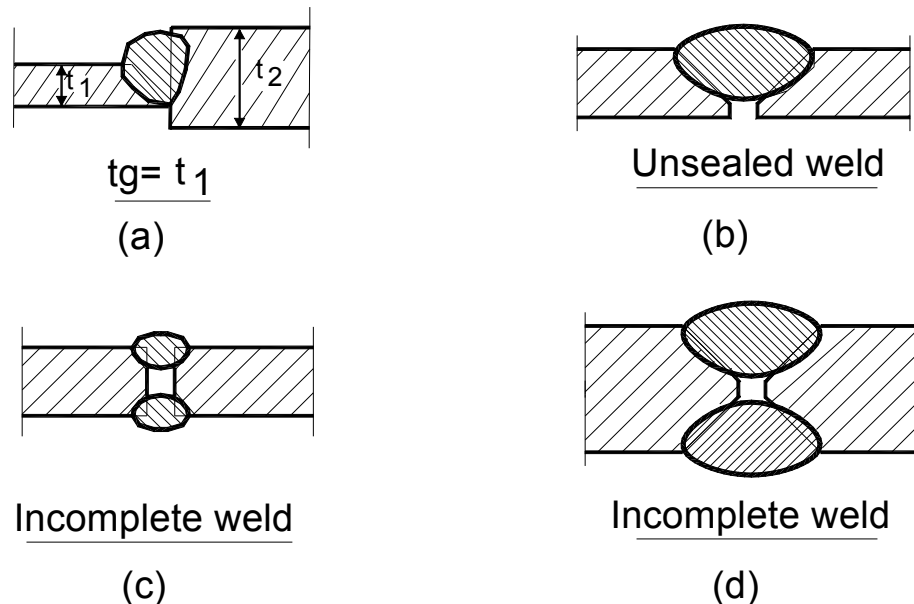


Figure (5.4) Incomplete Penetration and Unsealed Welds

5.5.2.3 Constructional Restrictions And Remarks

1. Single V and U groove welds shall be sealed, whenever possible by depositing a sealing run of weld metal on the back of the joint. Where this is not done, the maximum stress in the weld shall be (except as provided otherwise below) not more than one half of the corresponding permissible stresses indicated in Clause 5.5.2.2.

2. In the case of single and double V and U butt weld 18 mm , and over in size, in dynamically loaded structures, the back of the first run shall be cut out to a depth of at least 4 mm , prior to the application of subsequent runs. The grooves thus formed and the roots of single V and U groove welds shall be filled in and sealed.

3. When it is impossible to deposit a sealing run of weld metal on the back of the joint, then provided that backing material is in contact with the back of the joint, and provided also that the steel parts are beveled to an edge with a gap not less than 3 mm and not more than 5 mm, to ensure fusion into the root of the V and the backing material at the back of the joint, the permissible stresses may be taken as specified in Clause 5.5.2.2.

4. Possible defects that may result in discontinuities within the weld are to be avoided. Some of the more common defects are: incomplete fusion, inadequate joint penetration, porosity, undercutting, inclusion of slag and cracks (refer to Section 5.8)

5.a- Butt welds shall be built up so that the thickness of the reinforcement at the center of the weld is not less than the following:

- Butt welds \leq 30 mm in size reinforce by 10%
- Butt welds $>$ 30 mm in size reinforce by 3mm.

b- Where flush surface is required, specially in dynamic loading, the butt weld shall be built up as given in (a) and then dressed flush.

5.6 DESIGN, STRENGTH AND LIMITATIONS OF FILLET WELDED CONNECTIONS

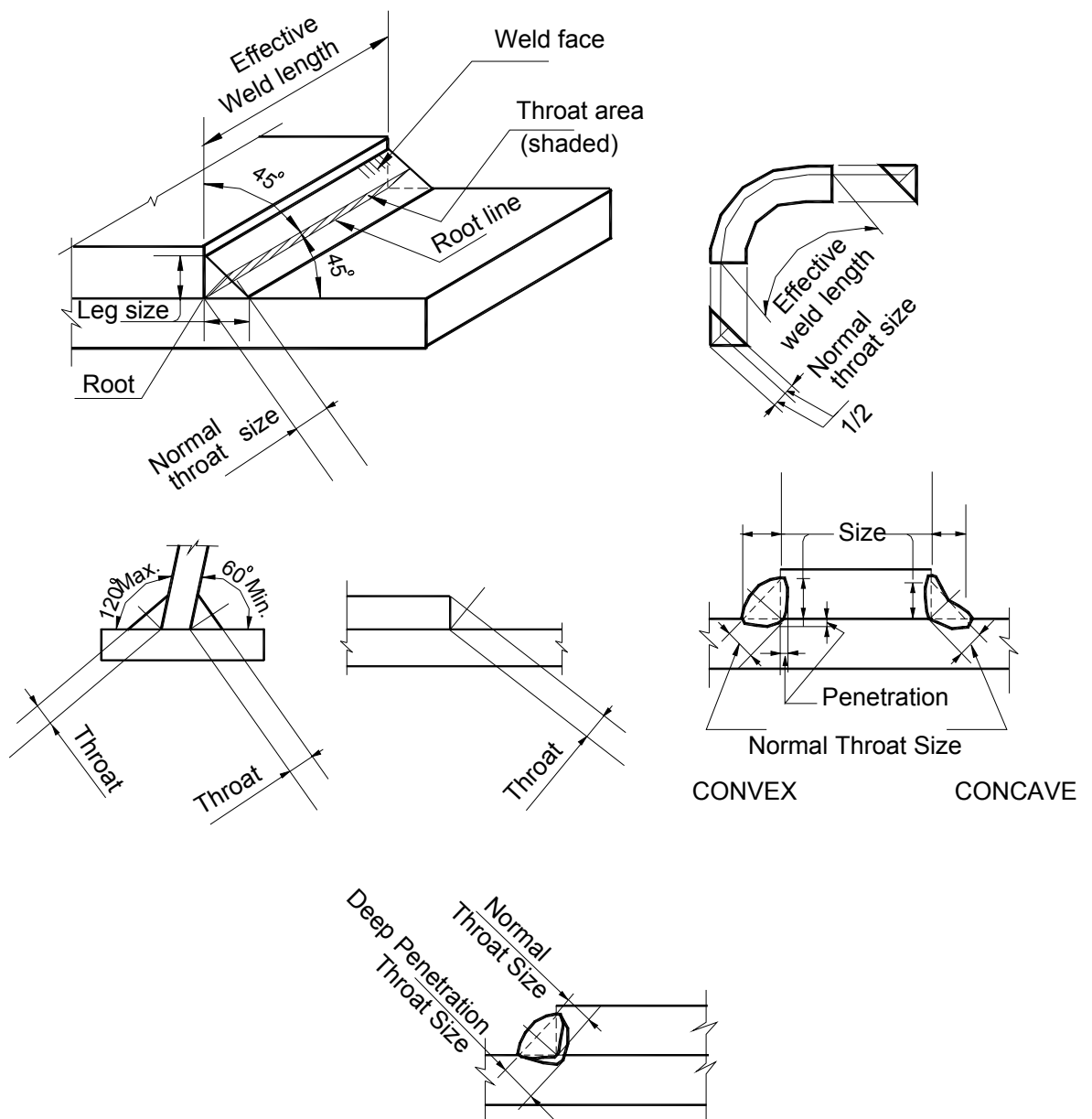


Figure (5.5) Fillet Weld Nomenclature

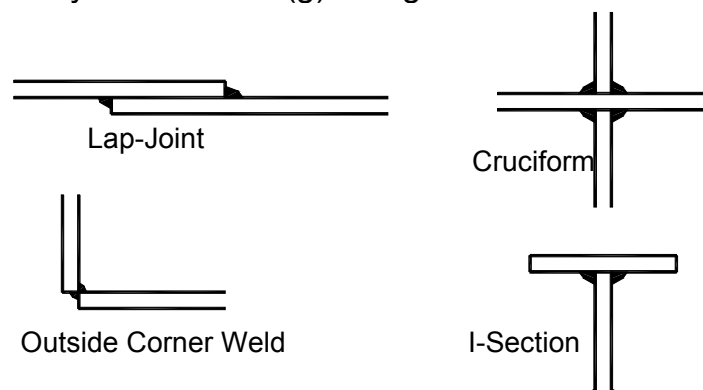
5.6.2 Different Types of Fillet Welded Connections

Fillet welds are made between plates surfaces which are usually at right angles, but the angle between the plates may vary from 60° to 120° . Tee joints, corner welds and cruciform joints are all combinations of fillet welds and are as shown in Fig. 5.6.

The ideal fillet is normally of the mitre shape which is an isosceles triangle as shown in Fig. 5.7. (h). The mitre and convex welds are stronger than a concave fillet weld of the same leg length when the weld is subject to static loadings, but the concave is stronger when subject to dynamic loadings.

Vertical welds made upwards in one run, are generally convex. Usually low currents produce the convex welds.

The penetration of the weld should reach the root where the contour of penetration is usually as shown in (g) of Fig. 5.7.



Fig

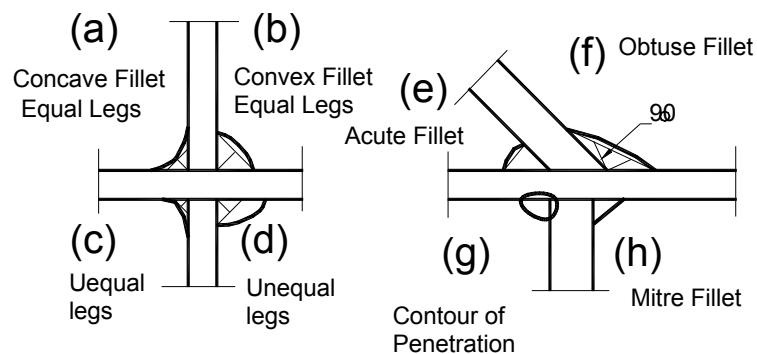


Figure (5.7) Fillet Weld Configurations

5.6.3 Strength of Fillet Welds

5.6.3.1 Effective Area of Fillet Welds

The effective weld section is equal to the largest triangle which can be inscribed between the fusion surfaces and the weld surface, provided there is as a minimum root penetration, this penetration is not taken into account. The effective throat (t) is then the distance from the root to the surface of the isosceles triangular weld along the line bisecting the root angle as shown in Fig. 5.8.

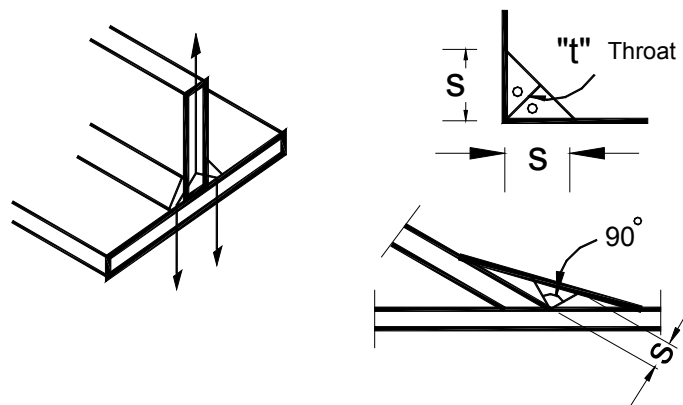


Figure (5.8) Dimensions of Size and Throat of Fillet Weld

Fillet welds are stressed across the throat (t) of the weld, while their size is specified by the leg length (s) where:

$$t = K \cdot s \quad \text{5.1}$$

The value of “K” depends on the angle between the fusion faces and it may be taken as follows:

Degree	60° – 90°	91° – 100°	101° – 106°	107° – 113°	114° – 120°
K	0.7	0.65	0.6	0.55	0.5



5.6.3.2 Strength and Permissible Stresses

The stress in a fillet weld loaded in an arbitrary direction can be resolved into the following components :

- f_{\perp} = the normal stress perpendicular to the axis of the weld.
- $q_{//}$ = the shear stress along the axis of the weld.
- q_{\perp} = the shear stress perpendicular to the axis of the weld.

These stresses shall be related to the size (s) of the legs of the isosceles triangle inscribed in the weld seam if the angle between the two surfaces to be welded is between 60° and 90° . When this angle is greater than 90° the size of the leg of the inscribed rectangular isosceles triangle shall be taken.

The permissible stresses F_{pw} for all kinds of stress for fillet welds must not exceed the following:

$$\text{All kind of stresses } F_{pw} \leq 0.2 F_u \quad \mathbf{5.2}$$

.....

Where F_u is the ultimate strength of the base metal (see table 5.1).

In case where welds are simultaneously subject to normal and shear stresses, they shall be checked for the corresponding principal stresses. For this combination of stresses, an effective stress value f_{eff} may be utilized and the corresponding permissible weld stress is to be increased by 10 % as follows:

$$f_{eff} = \sqrt{f_{\perp}^2 + 3(q_{\perp}^2 + q_{//}^2)} \quad \text{.....} \leq 1.1 F_{pw} \quad \mathbf{5.3}$$

The effective length of a fillet weld is usually taken as the overall length of the weld minus twice the weld size (s) as deduction for end craters.

5.6.3.3 Different Limitations Regarding Fillet Welds

a- Deposited Fillet Weld Metal

i- The limiting angles between fusion faces for load transmission shall not be greater than 120° and not less than:-

- 60° for flat, and down hand welding
- 70° for vertical welding
- 80° for overhead welding

ii- The minimum leg length of the fillet weld as deposited shall not be less than the specified size. The throat of a fillet weld as deposited shall be not less than $6/10$ and $9/10$ of the minimum leg length in the case of concave and convex fillets respectively as shown in Fig. 5.9.

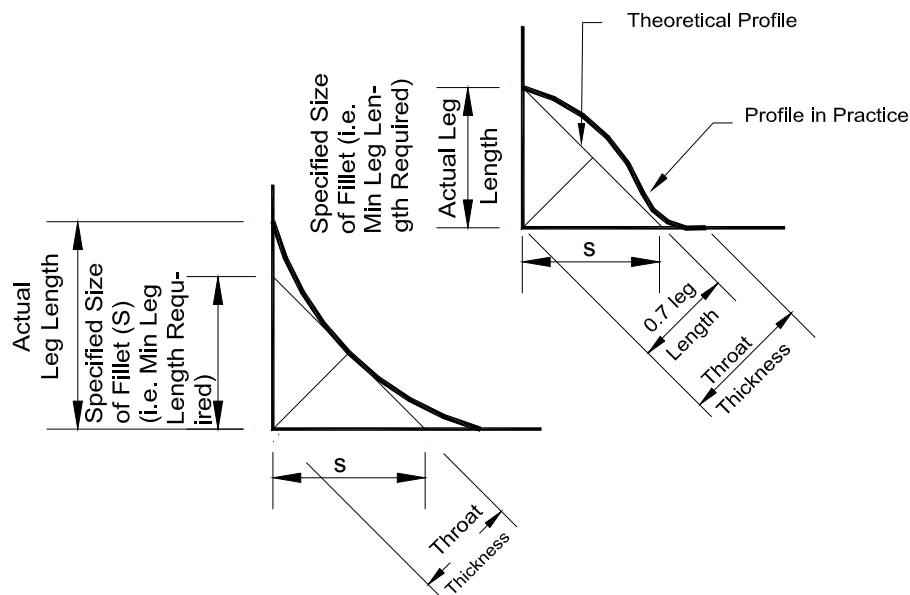


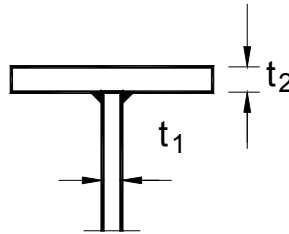
Figure (5.9) Definition of Throat in a Fillet Weld

b- Size of Fillet Welds

i- The maximum size of fillet weld should not exceed the thickness of the thinner plate to be welded.

- iii- It is recommended that the following limitations in sizes of fillet welds as related to the thickness of the thicker part to be joined should be observed as shown in Fig. 5.10.

t (max. of t ₁ or t ₂) (mm)	Size s (mm)
≤ 10	≥ 4
10-20	≥ 5
20-30	≥ 6
30-50	≥ 8
50-100	≥ 10



Figure(5.10) Thickness of Plates to be Welded

- iii- The minimum size of fillet welds is 4 mm for buildings and 6 mm for bridges.

c- Fillet Weld Length

- i- The effective length for load transmission should not be less than 4 times the weld size (s) or 5 cm whichever is largest.

- ii- The maximum effective length of fillet welds should not exceed 70 times the size. Generally in lap joints longer than 70 s a reduction factor β allowing for the effects of non- uniform distribution of stress along its length is to be utilized where:

$$\beta = 1.2 - 0.2 L / (70 s) \dots\dots\dots 5.4$$

Where

L = overall length of the fillet weld.

$$\beta \leq 1$$

iii- There are no limitations for the length of fillet weld for beam- to column connections as well as for the flange to web weld in welded bu

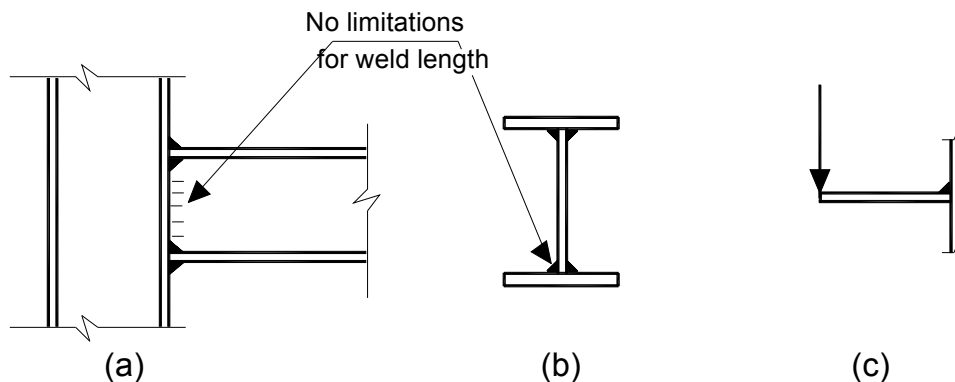


Figure (5.11) Different Locations of Fillet Welds

d- Single Fillet Weld

i- Single fillet weld subjected to normal tensile stress perpendicular to the longitudinal direction of the weld is not to be utilized, (Fig. 5.11c.) .

ii- The single side fillet weld between the flanges and web in I girders shall be made with a penetration of at least half the web thickness.

iii- For the single side fillet flange – to- web weld, this fillet weld shall be completed on the other side of the web and made symmetrical at supports, and at the position of concentrated loads where the web is not stiffened by vertical stiffeners.

iv- Single side fillet welds may be utilized only for static loads.

e- Intermittent Fillet Weld

i- Intermittent welds shall not be used in parts intended to transmit stresses in dynamically loaded structures.

ii- The clear distance between effective lengths of consecutive intermittent fillet welds, whether chained (L_1) or staggered (L_2), shall not exceed 12 times the thickness of the thinner part in compression or 16 times in tension and in no case shall it exceed 20 cm. (See Fig.



5.12) .

iii- In a line of intermittent fillet welds, the welding shall extend to the ends of the connected parts.

For staggered welds this applies generally to both edges but need not apply to subsidiary fittings or components such as intermediate stiffeners.

iv- For a member in which plates are connected by means of intermittent fillet welds, a continuous fillet weld shall be provided on each side of the plate for a length (L_o) at each end equal to at least three quarters of the width of the narrower plate connected (see Fig. 5.12) .

v- Bridge stiffeners and girder connections are permitted to be directly welded with the compression flange. In the case of the tension flange, intermediate plates (not welded to the flange) shall be inserted between the flange and the stiffener in order to prevent weakening of the flange by transverse welds. Where intermittent welds are used, the clear distance between consecutive welds, whether chained or staggered shall not exceed 16 times the thickness of the stiffener. The effective length of such weld shall not be less than 10 times the thickness of the stiffener in the case of staggered welds and 4 times in the case of chained welds, or one quarter the distance between stiffeners whichever is smallest.

5.7 PLUG AND SLOT WELDS

The stress transfer of plug and slot welds is limited to resisting shear loads in joints at planes parallel to the faying surface. The shear capacity is calculated as the product of the area of the hole or slot and the design shear stress as is previously mentioned in Clause 5.6.3.2. (Equations 5.2 and 5.3)

The proportions and spacing of holes and slots and the depth are illustrated in Fig. 5.13.

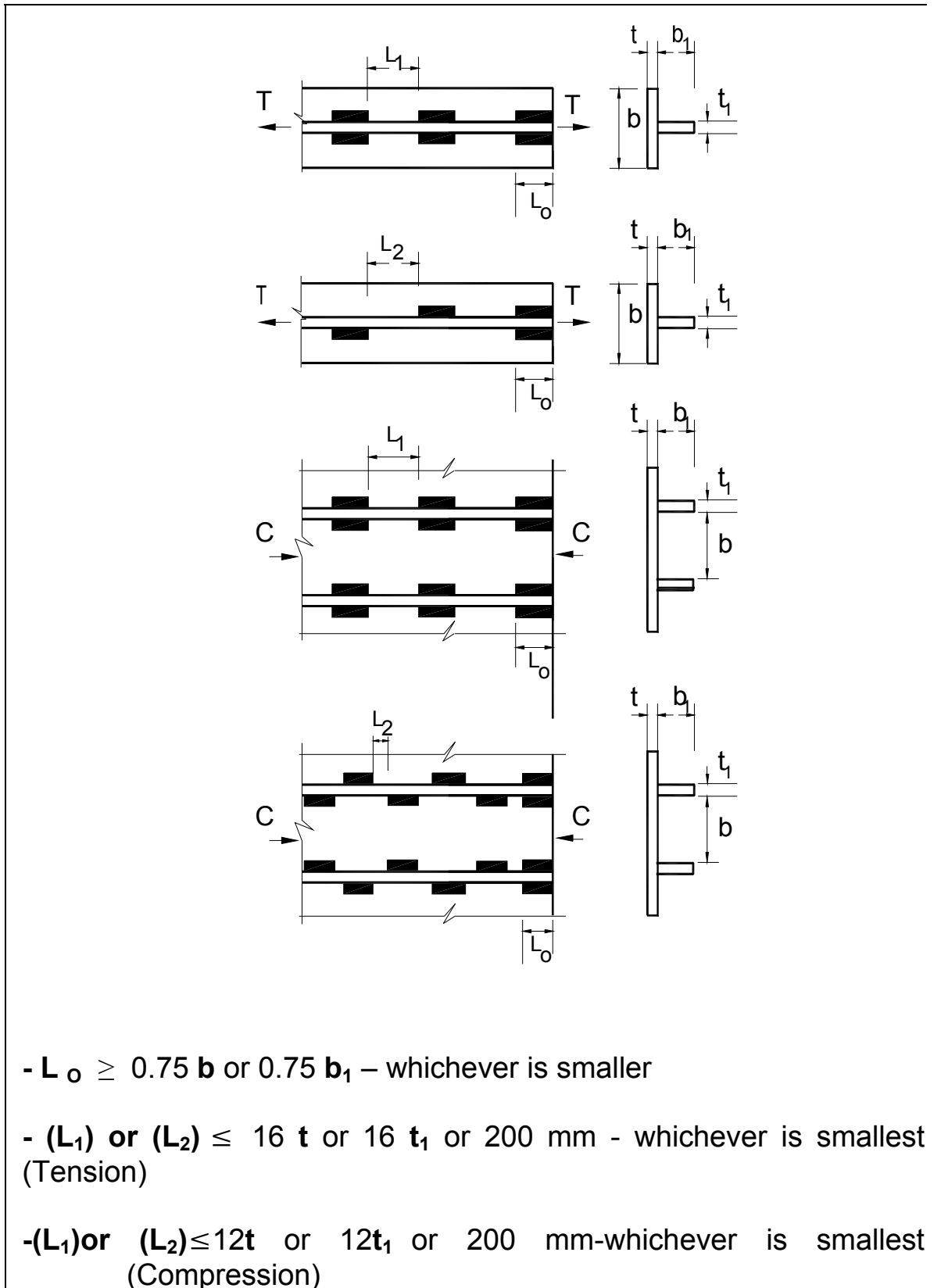


Figure (5.12) Intermittent Fillet Welds

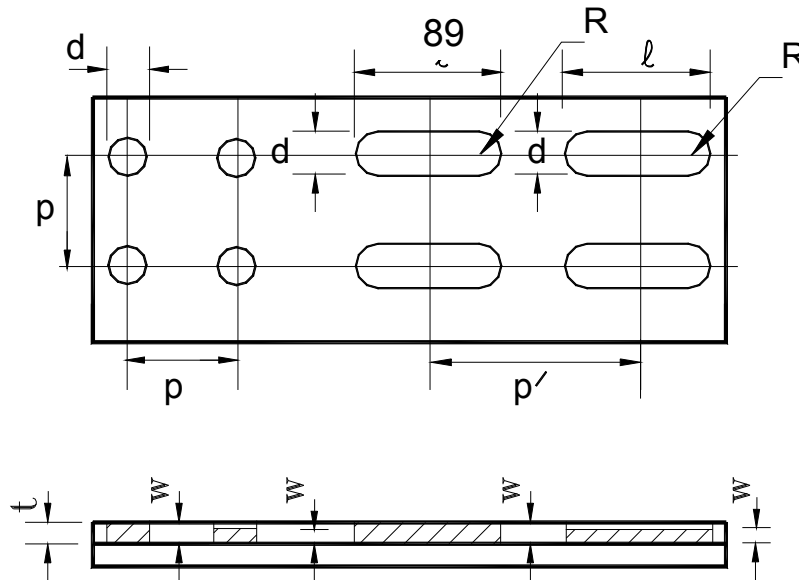


Figure (5.13) Definition of Plug and Slot Welds

Plate Thickness t (mm)	Min. Hole dia or Slot width d_{min} (mm)	Hole and Slot Proportions Spacing and Depth of Weld	
5 & 6	14	$d \geq (t+8)$ mm preferably rounded to next higher odd 2 mm; also $d \leq 2.25 t$ or $d_{min} + 3$ mm whichever is greater	
7 & 8	16	$p \geq 4d$	<u>Depth of filling of plug and slot welds (w):</u> Where $t \leq 16$ mm, $w = t$ Where $t \geq 16$ mm, $w = t/2$ but not less than 16 mm.
9 & 10	18	$p' \geq 2l$	
11 & 12	20	$l \leq 10 w$	
13 & 14	22	$R = d/2$	
15 & 16	24	$R \geq t$	

N.B. There are no limitations for the edge distances.

5.8 GENERAL RESTRICTIONS TO AVOID UNFAVOURABLE WELD DETAILS

5.8.1 Lamellar Tearing

Lamellar tearing is a separation (or crack) in the base metal, caused by through – thickness weld shrinkage strains. The probability of this failure can be minimized by:

- i- Using small weld size providing the shrinkage to be accommodated.
- ii- The welding procedure should also establish a welding sequence such that the component restraint and the internal restraints in the weldment are held to a minimum.
- iii- The use of a welding procedure with low hydrogen weld and an effective preheating minimize lamellar tear.

Some joints susceptible to lamellar tearing can be improved by careful detailing as shown in Fig. 5.14.

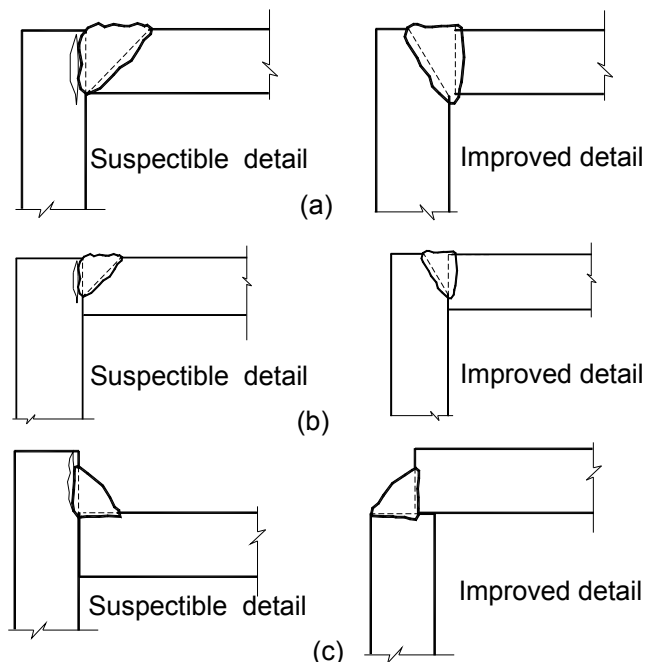


Figure (5.14) Improved Welded Connections to Reduce Lamellar Tear

5.8.2. Notches and Brittle Fracture

i- The one sided fillet welds can result in severe notches as shown in Fig. 5.15a. The remedy is to use two fillets one on each side. A similar condition arises with partial penetration groove welds.

ii- Backing bars can cause a fatigue weld notch if they are welded as shown in Fig. 5.15b. A remedy would be to weld in the groove as in Fig. 5.15c, where any undercut would be filled, or at least backed up by the final weld joint. The backing bars should also be continuous throughout its length.

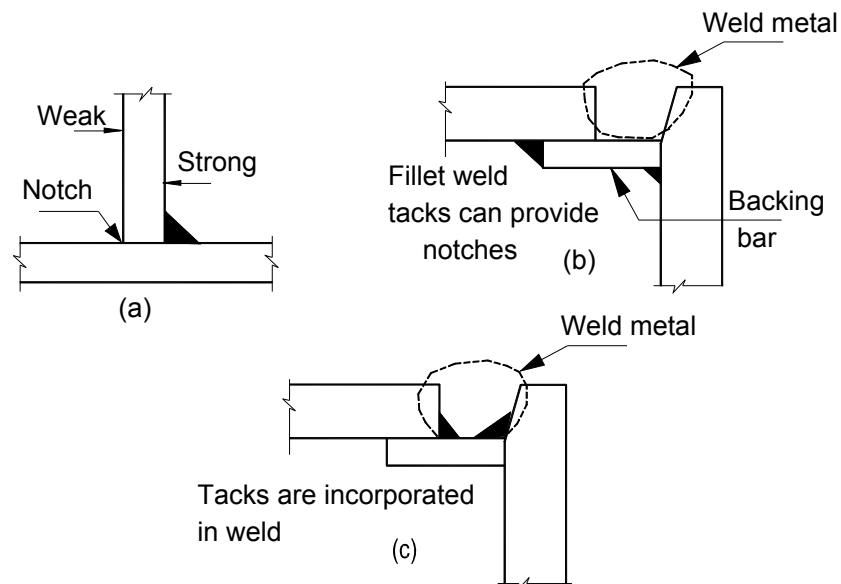


Figure (5.15) Notches and Brittle Fracture

5.9 WELD INSPECTION METHODS

The designer must specify in the contract document the type of weld inspection required as well as the extent and application of each type of inspection.

Table 5.5 summarizes the characteristics and capabilities of the five most commonly used methods for welding inspection.

Table (5.5) Characteristics of Common Weld Inspection Methods

Inspection Method	Characteristics and Applications	Limitations
Visual (VT)	Most common, most economical. Particularly good for single pass.	Detects surface imperfections only.
Dye Penetrant (DPT)	Will detect tight cracks, open to surface.	Detects surface imperfections only. Deep weld ripples and scratches may give false indications.
Magnetic Particle (MT)	Will detect surface cracks and subsurface cracks to about 2 mm depth with proper magnetization. Indications can be preserved on clear plastic tape.	Requires relatively smooth surface. Careless use of magnetization prods may leave false indications.
Radiographic (RT)	Detects porosity, slag, voids, irregularities, lack of fusion. Film negative is permanent record.	Detects must occupy more than about 1 1/5 % of thickness to register. Only cracks partial to impinging beam register. Radiation hazards Exposure time increases with thickness.
Ultrasonic (UT)	Detects cracks in any orientation, Slag, lack of fusion, inclusions, lamellar tears, voids. Can detect a favorably oriented planar reflector smaller than 1mm. Regularly calibrate on 1 ½ mm dia drilled hole. Can scan almost any commercial thickness.	Surface must be smooth, Equipment must be frequently calibrated. Operator must be qualified. Exceedingly coarse grains will give false indications. Certain geometric configurations give false indication of flaws.



CHAPTER 6

BOLTED CONNECTIONS

6.1 MATERIAL PROPERTIES

6.1.1 Non- Pretensioned Carbon and Alloy Steel Bolts

For non – pretensioned bolts, where the forces acting transverse to the shank of the bolt are transmitted either by shear or bearing, the nominal values of the yield stress F_{yb} and the ultimate tensile strength F_{ub} are as given in Table 6.1 :-

Table (6.1) Nominal Values of Yield Stress F_{yb} and Ultimate Tensile Strength F_{ub} for Bolts

Bolt grade	4.6	4.8	5.6	5.8	6.8	8.8	10.9
F_{yb} (t/cm ²)	2.4	3.2	3.0	4.0	4.8	6.4	9.0
F_{ub} (t/cm ²)	4.0	4.0	5.0	5.0	6.0	8.0	10.0

These bolt grades are used in conjunction with structural components in steel up to St 52.

Bolts of grades lower than 4.6 or higher than 10.9 shall not be utilized.

Bolts of grades 4.6 up to 6.8 are made from low or mild carbon steel, and are the least expensive type of bolts for light structures.

Grade 8.8 is of heat - treated high strength steel and Grade 10.9 is also of heat – treated, but is of alloy steel.



6.1.2 Pretensioned High Strength Bolts

High strength bolts of grade 8.8 and 10.9 are mainly used as pretensioned bolts with controlled tightening, where the forces acting transverse to the shank are transmitted by friction (slip), and must conform with requirements of section 6.5.

6.1.3 Rivets

The rivet steel is a mild carbon steel and is available in two grades namely grade 1 and grade 2 where the corresponding ultimate tensile strength (F_{ur}) is 5.0 t/cm² and 6.0 t/cm², respectively.

Structural riveting has essentially been replaced by welding and bolting. Taken space to the rivet is given for reference to dimensions for assistance in modifying older existing buildings.

6.2 HOLES, CLEARANCES, WASHERS AND NUTS REQUIREMENTS

6.2.1 Holes

- i- Holes for bolts may be drilled or punched unless specified.
- ii- Where drilled holes are required, they may be sub- punched and reamed.
- iii- Slotted holes shall either be punched in one operation, or else formed by punching or drilling. Two round holes are completed by high quality flame cutting, and dressing to ensure that the bolt can freely travel.

6.2.2 Clearances in Holes for Fasteners

- i- Except for fitted bolts or where low- clearance or oversize holes specified, the nominal clearance in standard holes shall be:-
 - 1 mm for M12 and M14 bolts
 - 2 mm for M16 up to M24 bolts
 - 3 mm for M27 and larger



ii- Holes with 2 mm nominal clearance may also be specified for M12 and M14 bolts provided that the design meets the requirements specified in Clauses 6.4.1 and 6.4.2.

iii- Unless special clearances are specified, the clearance of fitted bolts shall not exceed 0.3 mm.

6.2.3 Nuts Constructional Precautions

i- For structures subject to vibration, precautions shall be taken to avoid any loosening of the nuts.

ii- If non- pretensioned bolts are used in structures subject to vibrations, the nuts should be secured by locking devices or other mechanical means.

iii- The nuts of pretensioned bolts may be assumed to be sufficiently secured by the normal tightening procedure.

6.2.4 Washers Utilities

i- Washers may not required for non-pretensioned bolts except as follows:-

- A taper washer shall be used where the surface is inclined at more than 3° to a plane perpendicular to the bolt axis.

- Washers shall be used where this is necessary due to a requirement to use longer bolt in order to keep the bolt threads out of a shear plane or out of a fitted hole.

ii- Hardened washers shall be used for pretensioned bolts under the bolt head as well as under the nut, whichever is to be rotated.

6.2.5 Tightening of Bolts

i- Non-pretensioned bolts shall be tightened sufficiently to ensure that sufficient contact is achieved between the connected parts.



ii- It is not necessary to tighten non-pretensioned bolts to the maximum tightening value given in Clause 6.5.3. However as an indication, the tightening required should be :

- That which can be achieved by one man using a normal prodger spanner or
- Up to the point where an impact wrench first starts to impact.

iii- Pretensioned bolts shall be tightened in conformity with Clause 6.5.3 .

6.3 POSITIONING OF HOLES FOR BOLTS AND RIVETS

6.3.1 Basis

i- The positioning of the holes for bolts and rivets shall be done such as to prevent corrosion and local buckling, and to facilitate the installation of the bolts and rivets.

ii- The positioning of the holes shall be also in conformity with the limits of validity of the rules used to determine the design bearing strength of the bolts and the rivets as given in Clause 6.4.2.

6.3.2 Minimum End Distance

i- The end distance e_1 from the center of a fastener to the adjacent end of any steel element, measured in the direction of load transfer (Fig. 6.1) should not be less than $1.5d$, where d is the nominal bolt diameter.

ii- The end distance should be increased if necessary to provide adequate bearing resistance (Clause 6.4.2) .

6.3.3 Minimum Edge Distance

The edge distance e_2 from the center of a fastener to the adjacent edge of any steel element, measured at right angles to the direction of load transfer (Fig. 6.1) should not be less than $1.5d$.

6.3.4 Maximum End or Edge Distance

The maximum end or edge distance shall be 12 times the thickness (t) of the smallest connected part under consideration.

6.3.5 Minimum Spacing

i- The spacing (s) between centers of fasteners in the direction of load transfer (Fig. 6.1) should not be less than 3d.

ii- The spacing (g) between rows of fasteners, measured perpendicular to the direction of load transfer (Fig. 6.1) should normally be not less than 3d.

6.3.6 Maximum Spacing in Compression Members

The spacing (s) of the fasteners in each row and the spacing (g) between rows of fasteners should not exceed the lesser of 14t or 200 mm. Adjacent rows of fasteners may be symmetrically staggered (Fig. 6.2).

6.3.7 Maximum Spacing in Tension Members

In tension members the center – to – center spacing $s_{1,i}$ of fasteners in inner rows may be twice that given in Clause 6.3.6. for compression members, provided that the spacing $s_{1,0}$ in the outer row along each edge does not exceed that given in Clause 6.3.6 (Fig. 6.3).

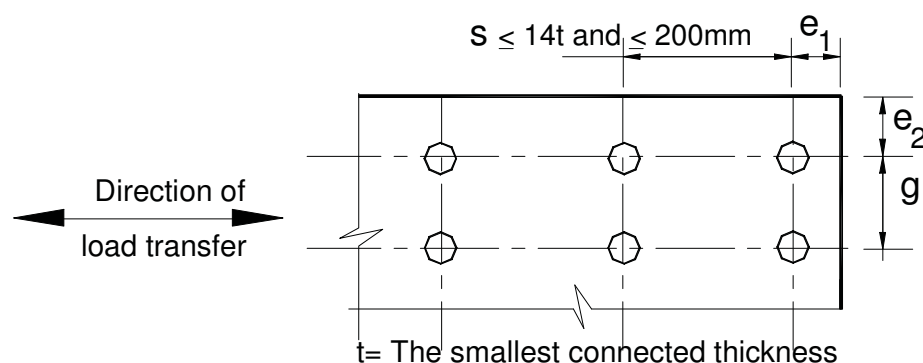


Figure (6.1) Spacing in Tension or Compression Members

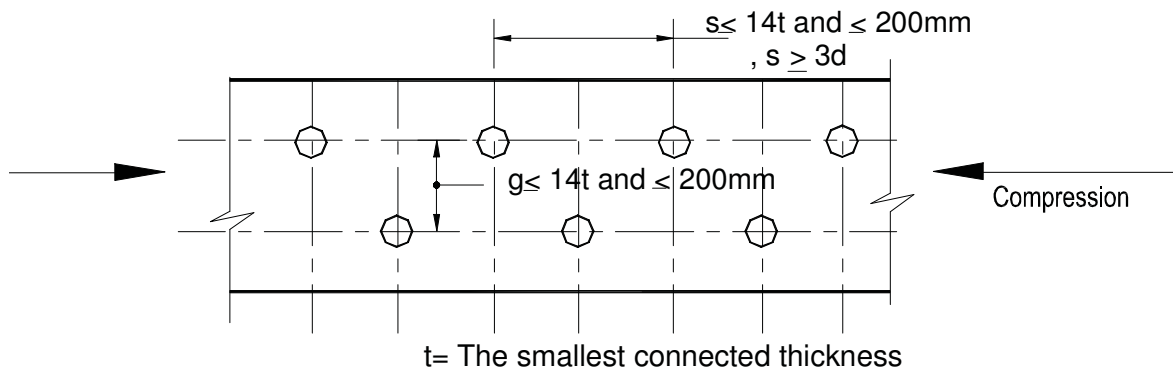


Figure (6.2) Staggered Spacing - Compression

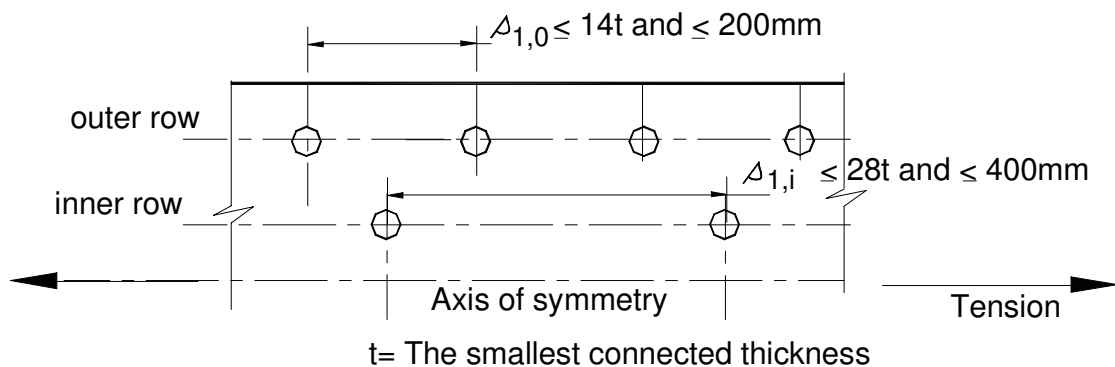


Figure (6.3) Maximum Spacing in Tension Members

6.3.8 Slotted Holes

i- The minimum distance (e_3) from the axis of a slotted hole to the adjacent end or edge of any steel element should not be less than $1.5d$ (Fig. 6.4).

ii- The minimum distance (e_4) from the center of the end radius of a slotted hole to the adjacent end or edge of any steel element should not be less than $1.5d$ (Fig. 6.4).

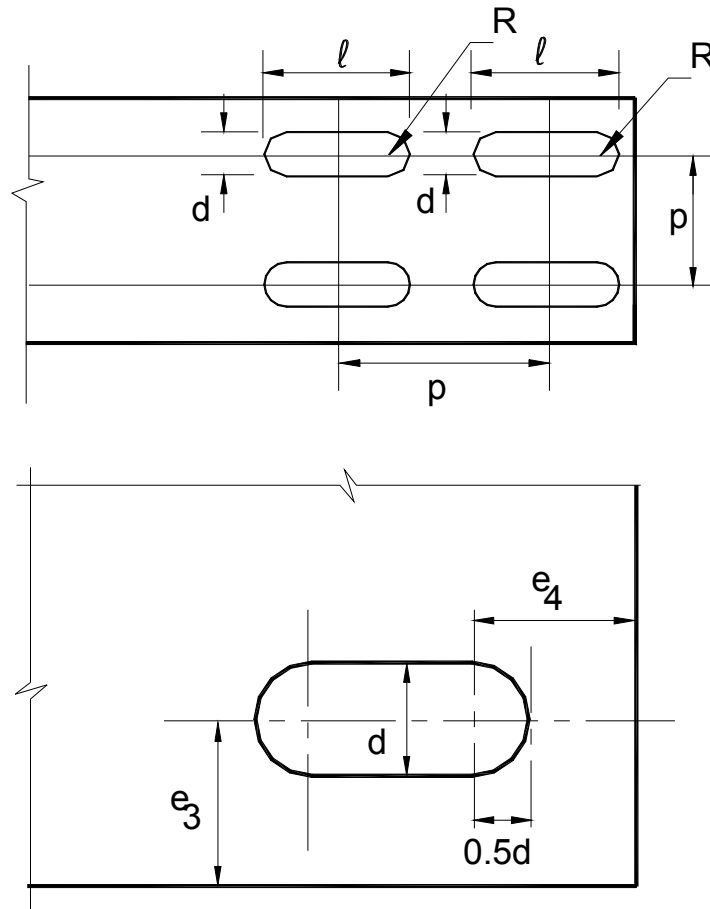


Figure (6.4) End and Edge Distances for Slotted Holes

6.4 STRENGTH OF NON-PRETENSIONED BOLTED CONNECTIONS OF THE BEARING TYPE

In this category ordinary bolts (manufactured from low carbon steel) or high strength bolts, from grade 4.6 up to and including grade 10.9 can be used. No pre-tensioning and special provisions for contact surfaces are required. The design load shall not exceed the shear resistance nor the bearing resistance obtained from Clauses 6.4.1 and 6.4.2.

6.4.1 Shear Strength R_{sh}

i- The allowable shear stress q_b for bolt grades 4.6, 5.6 and 8.8 shall be taken as follows:

$$q_b = 0.25 F_{ub} \dots\dots\dots 6.1$$



ii- For bolt grades 4.8, 5.8, 6.8, and 10.9, the allowable shear stress q_b is reduced to the following:-

$$q_b = 0.2 F_{ub} \dots\dots\dots 6.2$$

iii- For the determination of the design shear strength per bolt (R_{sh}), where the shear plane passes through the threaded portion of the bolt:-

$$R_{sh} = q_b \cdot A_s \cdot n \dots\dots\dots 6.3$$

Where :

- A_s = The tensile stress area of bolt.
- n = Number of shear planes.

iv- For bolts where the threads are excluded from the shear planes the gross cross sectional area of bolt (A) is to be utilised.

v- The values for the design of shear strength given in Equations 6.1 and 6.2 are to be applied only where the bolts used in holes with nominal clearances not exceeding those for standard holes as specified in Clause 6.2.2.

vi- M12 and M14 bolts may be used in 2mm clearance holes provided that for bolts of strength grade 4.8., 5.8, 6.8 or 10.9 the design shear stress is to be reduced by 15%.

6.4.2 Bearing Strength R_b

i- The bearing strength of a single bolt shall be the effective bearing area of bolt times the allowable bearing stress at bolt holes:-

$$R_b = F_b \cdot d \cdot \min \sum t \dots\dots\dots 6.4$$

Where :

- F_b = Allowable bearing stress.
- d = Shank diameter of bolt.
- $\min \sum t$ = Smallest sum of plate thicknesses in the same direction of the bearing pressure.



ii- For distance center- to center of bolts not less than 3d, and for end distance in the line of force greater than or equal to 1.5 d, the allowable bearing stress F_b (t/cm²):

$$F_b = \alpha F_u \dots\dots\dots 6.5$$

Where :

F_u = The ultimate tensile strength of the connected plates.

As the limitation of deformation is the relevant criteria the α -values of Equation 6.5 are given in Table 6.2.

Table (6.2) Values of α for Different Values of End Distance

	End distance in direction of force			
	$\geq 3d$	$\geq 2.5d$	$\geq 2.0d$	$\geq 1.5d$
α	1.2	1.0	0.8	0.6

6.4.3 Tensile Strength R_t

When bolts are externally loaded in tension, the tensile strength of a single bolt (R_t) shall be the allowable tensile bolt stress (F_{tb}) times the bolt stress area (A_s)

$$R_t = F_{tb} \cdot A_s \dots\dots\dots 6.6$$

With $F_{tb} = 0.33 F_{ub} \dots\dots\dots 6.7$

6.4.4 Combined Shear and Tension in Bearing-Type Connections

When bolts are subjected to combined shear and tension, the following circular interaction Equation is to be satisfied:

$$\dots\dots\dots 6.8$$



Where :

- $R_{sh.a}$ = The actual shearing force in the fastener due to the applied shearing force.
- $R_{t.a}$ = The actual tension force in the fastener due to the applied tension force.
- R_{sh} and R_t = The allowable shear and tensile strength of the fastener as previously given in Equations (6.3) and (6.6) respectively.

6.5 HIGH STRENGTH PRETENSIONED BOLTED CONNECTIONS OF THE FRICTION TYPE

6.5.1 General

In this category of connections high strength bolts of grades 8.8 and 10.9 are only to be utilized. The bolts are inserted in clearance holes in the steel components and then pretensioned by tightening the head or the nut in accordance with Clause 6.5.3 where a determined torque is applied. The contact surfaces will be firmly clamped together particularly around the bolt holes.

Any applied force across the shank of the bolt is transmitted by friction between the contact surfaces of the connected components, while the bolt shank itself is subjected to axial tensile stress induced by the pretension and shear stress due to the applied torque.

6.5.2 Design Principles of High Strength Pretensioned Bolts

6.5.2.1 The Pretension Force

The axial pretension force T produced in the bolt shank by tightening the nut or the bolt head is given by:-

$$T = (0.7) F_{yb} A_s \dots\dots\dots 6.9$$

Where :

- F_{yb} = Yield (proof) stress of the bolt material, (Table 6.1).
- A_s = The bolt stress area.



6.5.2.2 The Friction Coefficient or The Slip Factor “ μ ”

i- The friction coefficient between surfaces in contact is that dimensionless value by which the pretension force in the bolt shank is to be multiplied in order to obtain the frictional resistance P_S in the direction of the applied force.

ii- The design value of the friction coefficient depends on the condition and the preparation of the surfaces to be in contact. Surface treatments are classified into three classes, where the coefficient of friction μ should be taken as follows:-

$\mu = 0.5$ for class A surfaces.

$\mu = 0.4$ for class B surfaces.

$\mu = 0.3$ for class C surfaces.

iii- The friction coefficient μ of the different classes is based on the following treatments:

In class A:

- Surfaces are blasted with shot or grit with any loose rust removed, no painting.
- Surfaces are blasted with shot or grit and spray metallized with Aluminium.
- Surfaces are blasted with shot or grit and spray metallized with a Zinc based coating.

In class B:

- Surfaces are blasted with shot or grit and painted with an alkali-zinc silicate painting to produce a coating thickness of 50-80 μm .

In class C:

- Surfaces are cleaned by wire brushing, or flame cleaning, with any loose rust removed.

iv- If the coatings other than specified are utilized, tests are required to determine the friction coefficient. The tests must ensure that the creep deformation of the coating due to both the clamping force of the



bolt and the service load joint shear are such that the coating will provide satisfactory performance under sustained loading.

6.5.2.3. The Safe Frictional Load (P_s)

The design frictional strength for a single bolt of either grade 8.8 or 10.9 with a single friction plane is derived by multiplying the bolt shank pretension T by the friction coefficient μ using an appropriate safety factor γ as follows:-

$$P_s = \mu T / \gamma \dots\dots\dots 6.10$$

Where :

- T = Axial pretensioning force in the bolt.
- μ = Friction coefficient.
- γ = Safety factor with regard to slip .
 - = **1.25** and **1.05** for cases of loading **I** and **II** respectively for ordinary steel work.
 - = **1.6** and **1.35** for case of loading **I** and **II** respectively for parts of bridges, cranes and crane girders which are subjected mainly to dynamic loads.

Table 6.3 gives the pretension force (T) and the permissible frictional load (P_s) per one friction surface for bolts of grade 10.9.

6.5.2.4 Design Strength In Tension Connections

Where the connection is subjected to an external tension force (T_{ext}) in the direction of the bolts axis, the induced external tension force per bolt($T_{ext,b}$) is to be calculated according to the following relation:-

$$T_{(ext,b)} = T_{(ext)} / n \leq 0.6 T \dots\dots\dots 6.11$$

Where :

- n = The total number of bolts resisting the external tension force $T_{(ext)}$.



Table (6.3) Properties and Strength of High Strength Bolts (Grade 10.9*)

Bolt Diameter (d) mm	Bolt Area (A) cm ²	Stress Area (A _s) cm ²	Pretension Force (T) tons	Required Torque (M _a) kg.m	Permissible Friction Load of One Bolt Per One Friction Surface (P _s) tons									
					Ordinary Steel Work					Bridges and Cranes				
					St. 37&42-44 (μ=0.4)		St. 50-55 (μ=0.5)		St. 37&42-44 (μ=0.4)		St. 50-55 (μ=0.5)			
					Cases of Loading									
I		II		I		II		I		II				
M12	1.13	0.84	5.29	12	1.69	2.01	2.11	2.52	1.32	1.56	1.65	1.95		
M16	2.01	1.57	9.89	31	3.16	3.37	3.95	4.71	2.47	2.92	3.09	3.66		
M20	3.14	2.45	15.43	62	4.93	5.90	6.17	7.36	3.85	4.56	4.82	5.71		
M22	3.80	3.03	19.08	84	6.10	7.27	7.63	9.10	4.77	5.65	5.96	7.06		
M24	4.52	3.53	22.23	107	7.11	8.45	8.89	10.60	5.55	6.58	6.94	8.22		
M27	5.73	4.59	28.91	157	9.25	11.03	11.56	13.78	7.22	8.55	9.03	10.70		
M30	7.06	5.61	35.34	213	11.30	13.48	14.13	16.86	8.83	10.46	11.04	13.07		
M36	10.18	8.17	51.47	372	16.47	19.64	20.58	24.55	12.86	15.24	16.08	19.05		

$$T = (0.7) F_{yb} \cdot A_s \quad M_a = 0.2 \text{ d.T.} \quad P_s = \mu T / \gamma$$

* For HSB grade 8.8 , the above values shall be reduced by 30%

In addition to the applied tensile force per bolt $T_{(ext,b)}$, the bolt shall be proportioned to resist the additional induced prying force (P) (Fig. 6.5).

The prying force (P) depends on the relative stiffness and the geometrical configuration of the steel element composing the connection. The prying force should be determined according to Clause 6.9 and hence the following check is to be satisfied:-

$$T_{(ext,b)} + P \leq 0.8 T \quad \dots\dots\dots 6.12$$

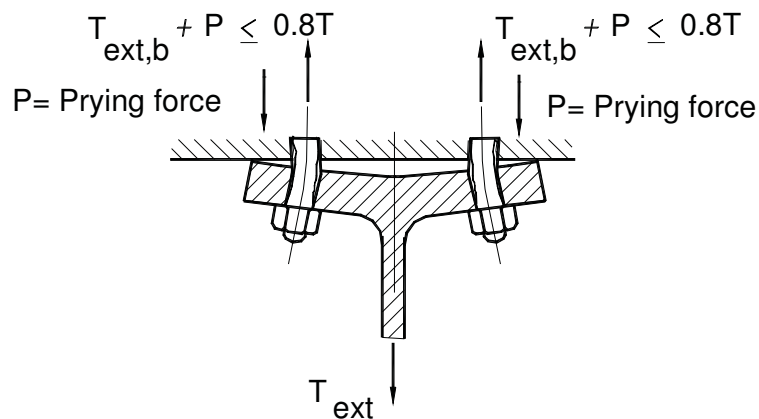


Figure (6.5) Prying Force

6.5.2.5 Design Strength in Connections Subjected to Combined Shear and Tension

In connections subjected to both shear (Q) and tension (T_{ext}), the design strength for bolt is given by the following formulae:-

$$\left. \begin{aligned} Q_b &\leq \frac{\mu (T - T_{ext,b})}{\gamma} \\ T_{(ext,b)} + P &\leq 0.8 T \end{aligned} \right\} \dots\dots\dots 6.13$$

6.5.2.6 Design Strength in Connections Subjected to Combined Shear and Bending Moment

In moment connections of the type shown in Fig. 6.6, the loss of clamping forces in region “A” is always coupled with a corresponding increase in contact pressure in region “B”. The clamping force remains unchanged and there is no decrease of the frictional resistance as given by the following :-

$$P_s = \mu T / \gamma \quad \dots\dots\dots 6.14$$

The induced maximum tensile force $T_{(ext,b,M)}$ due to the applied moment (M) in addition to the prying force P that may occur, must not exceed the pretension force as follows:-

$$T_{(ext,b,M)} + P \leq 0.8T \quad \dots\dots\dots 6.15$$

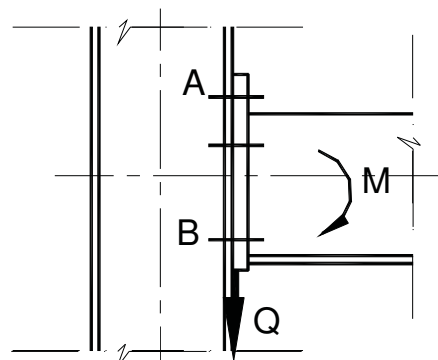


Figure (6.6) Connections Subjected to Combined Shear and Bending Moment

6.5.2.7 Design Strength in Connections Subjected to Combined Shear, Tension, and Bending Moment

When the connection is subjected to shearing force (Q), a tension force (T_{ext}) and a bending moment (M), the design strength per bolt is to be according to the following formulae:-



$$\left. \begin{aligned}
 Q_b &\leq \frac{\mu (T - T_{ext,b})}{\gamma} \\
 T_{(ext,b)} + T_{(ext,b,M)} + P &\leq 0.8T
 \end{aligned} \right\} \dots \dots \dots \quad \mathbf{6.16}$$

6.5.3 Bolting Procedure and Execution

Bolts may be tightened by calibrated wrenches, which can indicate either the applied torque or the angle of rotation of the nut.

i- For the first method, torque wrenches which have a cut-out-device to limit the required amount of the applied torque must be employed. Wrenches may be of the manual , pneumatic, or electric-type. The torque “*M_a*” (Table 6.3) required to induce the pretensioning force “*T*” shall be calculated as follows:

$$\mathbf{M_a = k.d.T} \quad \dots \dots \dots \quad \mathbf{6.17}$$

Where :

- M_a* = Applied torque.
- k* = Coefficient (about **0.2** for all bolts diameters)
- d* = Diameter of bolt.
- T* = Bolt pretension force.

ii- The second method of tightening is based on a predetermined rotation of the nut. The tightening can be achieved in different ways as follows:

- a-** The parts to be joined are first brought into contact by making the bolts snug tight by a few impacts of an impact wrench. Following this initial step each nut is tightened one half turn.
- b-** The bolt is first tightened using a wrench until the several plies of the joint achieve a “ snug fit” after which the nut is further turned by the amount:-



$$\alpha = 90^{\circ} + t + d \dots\dots\dots 6.18$$

Where :

- α = Rotation in degrees.
- t = Total thickness of connected parts in mm .
- d = Bolt diameter in mm.

6.5.4 Preparation of Contact Surfaces

The contact surfaces must be free from dust, oil, paint, etc. Spots of oil cannot be removed by flame cleaning without leaving harmful residues, and must be removed by chemical means. It is sufficient to remove any film of rust or other loose material by brushing with a soft steel brush.

6.5.5 Protection Against Corrosion

Parts to be joined with high strength bolts of the friction type must be protected against corrosion, by suitable protection against entry of humidity between the contact surfaces as well as the bolt holes.

For structural components, where the contact surfaces have been prepared for a prestressing process, and are stored for long periods, there is a risk of rusting. An inspection regarding the coefficient of friction is essential.

6.5.6 Inspection

6.5.6.1 Tensioning Force

One of the following two procedures may be adopted to check that the specified torque “ M_a ” has been applied:-

i- The bolt is turned a further 10° for which at least the specified torque has to be applied.

ii- The position of the nut on the bolt which is to be checked is marked. The bolt is then held firmly and the nut is unscrewed by 1/6 of a complete turn. To turn the nut back to its original position, it must be necessary to apply the specified torque.

6.5.6.2 Friction Coefficient Check

It is desirable to make random checks of the friction coefficient achieved by surface preparation .

6.6 ALLOWABLE SHEAR RUPTURE STRENGTH

At beam end connections , where the top flange is coped and for similar situations where failure might occur by shear along a plane through the fasteners or by a combination of shear along a plane through the fasteners plus tension along any perpendicular plane A_t such as the end of a beam web or as thin bolted gusset plates in single or double shear (Fig. 6.7) the allowable shear stress of Chapter (2) acting on the net shear area A_{sh} is to be increased by 15% :

$$\sigma_s = 0.4 F_u$$

6.19

P=

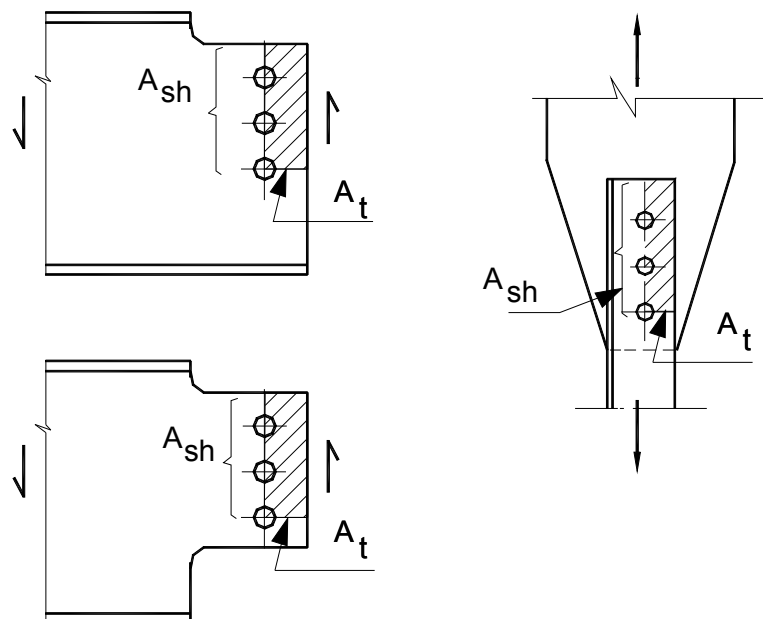


Figure (6.7) Failure by Tearing Out of Shaded Area



6.7 ADDITIONAL REMARKS

6.7.1 Long Grip

i- Bolts of grade 4.6 and 4.8, which carry calculated stresses fulfilling section 6.4 with a grip exceeding 5 times the bolt diameter (**d**) shall have their number increased 1% for each 1 mm increase in the grip.

ii- This provision for other grades of bolts shall be applicable only with grip exceeding **8d**.

6.7.2 Long Joints

i- Where the distance L_i between the centers of end fasteners in a joint, measured in the direction of the transfer of force (Fig. 6.8) is more than $15d$, the allowable shear and bearing stresses q_b and F_b of all the fasteners calculated as specified in Clauses 6.4.1 and 6.4.2 shall be reduced by a reduction factor B_L given by the following:

$$B_L = 1 - \frac{L_i - 15d}{200 d} \dots\dots\dots 6.21$$

Where $0.75 \leq B_L \leq 1.0$

ii- This provision is not to be applied, where there is a uniform distribution of force transfer over the length of the joint such as the transfer from the web of I section to the column flange.

6.7.3 Single Lap Joints with One Bolt

i- In single lap joints with only one bolt, (Fig. 6.9) the bolt shall be provided with washers under both the head and the nut to avoid pull-out failure.

ii- The bearing strength determined in accordance with Clause 6.4.2 shall be limited to :

$$R_b \leq 0.75 F_u \cdot d \cdot t \dots\dots\dots 6.22$$

iii- In case of high strength bolts of grades 8.8 and 10.9 hardened

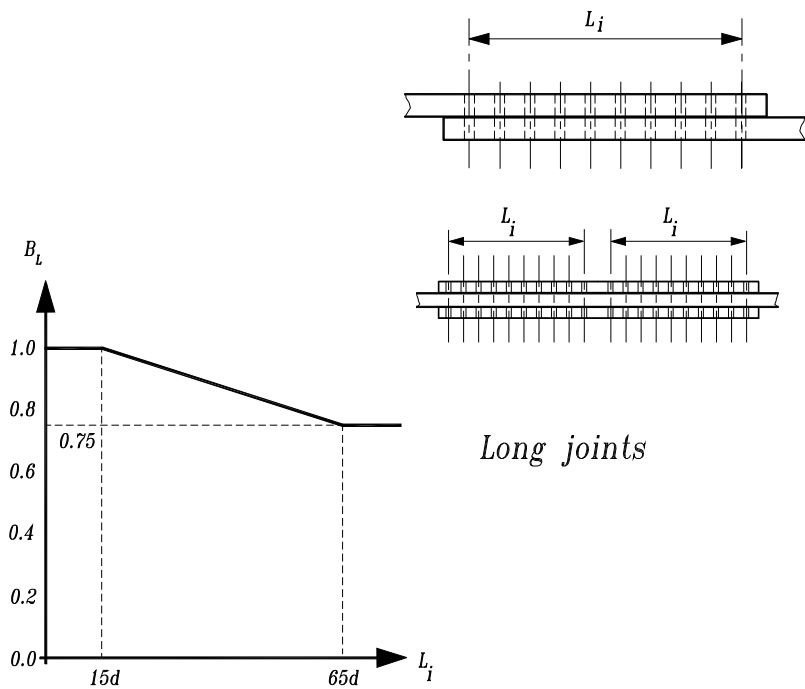


Figure. 6.10. Long joints

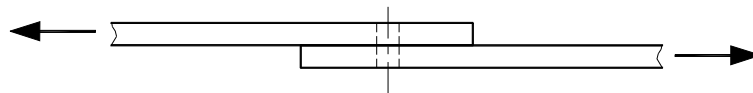


Figure (6.9) Single Lap Joint With One Bolt

Figure. 6.11.

6.7.4 Fasteners Through Packings

i- Where bolts transmitting load in shear and bearing pass through packings of total thickness t_p greater than one-third of the bolt diameter d , the allowable shear stress calculated as specified in Clause 6.4.1 shall be reduced using a reduction factor B_b as follows:-

$$\text{Where } B_b \leq 1 \quad \dots\dots\dots \quad \mathbf{6.23}$$

ii- For double shear connections with packings on both sides of a splice, t_p should be taken as the thickness of the thicker packing.



6.7.5 Anchor Bolts and Tie Rods

The allowable shear and tensile stresses through the threaded portion as prescribed in Clauses 6.4.1 and 6.4.3 are restricted to bolts of different grades.

For other threaded parts with cut threads as anchor bolts or threaded tie rods fabricated from round steel bars, where the threads are cut by the steelwork fabricator and not by a specialist bolt manufacturer, the allowable shear and tensile stresses given by Equations 6.1 and 6.7 are to be decreased by 15% .

6.8 HYBRID CONNECTIONS

i- When different forms of fasteners are used to carry a shear load, or when welding, and fasteners are used in combination, then one form of connector shall normally be designed to carry the total load.

ii- As an exception to this provision, prestressed high- strength bolts in connections designed as a friction type may be assumed to share load with welds, provided that the final tightening of the bolts is carried out after the welding is completed.

6.9 THE DETERMINATION OF THE PRYING FORCE (P) FOR PRESTRESSED HIGH STRENGTH BOLTED CONNECTIONS SUBJECTED TO TENSION AND /OR BENDING MOMENT

6.9.1 Configuration

(Fig. 6.10a, b and c) illustrate the most common types of connections, where the outer overhangings may press on their corresponding supports causing the prying force “P”. The prying action depends on the flexibility of the Tee stub flange, and the end plate which is denoted in (Fig. 6.10a, b and c) by the thickness (t_p).

6.9.2 Determination of The Prying Force P

In order to determine the prying force P, the connection is to be transformed to an equivalent Tee stub connection as shown in Fig. 6.11. The prying force P can be determined using the following relation :-

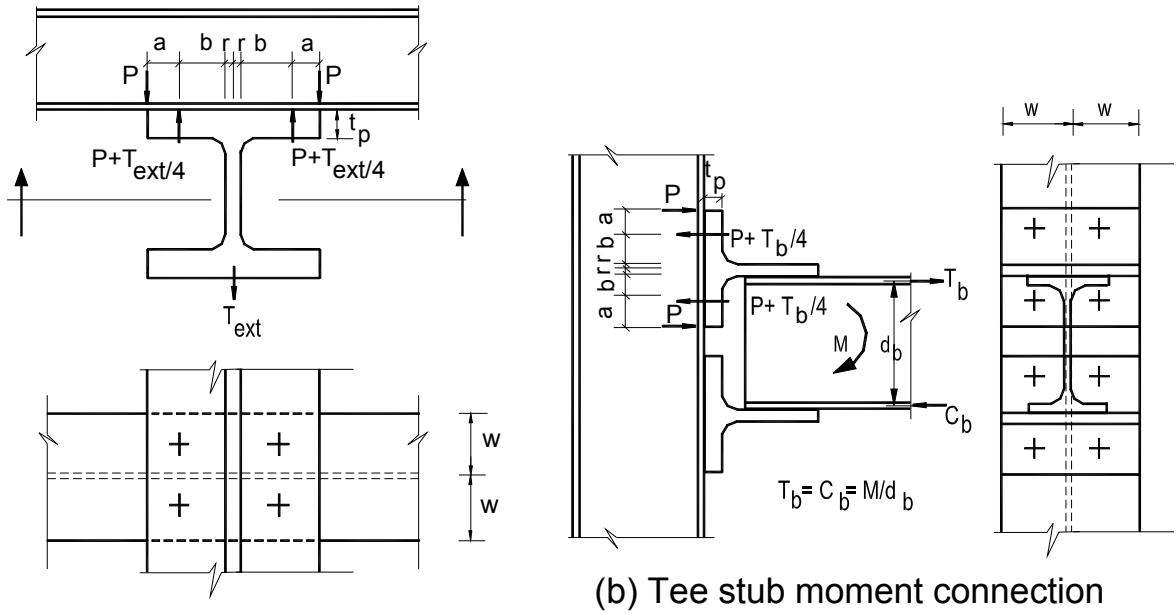
$$P = \left[\frac{\frac{1}{2} - \frac{wt_p^4}{30ab^2 A_s}}{\left(\frac{3a}{4}\right)\left(\frac{a}{4b} + 1\right) + \frac{wt_p^4}{30ab^2 A_s}} \right] \cdot T_{\text{ext,b,M}} \text{ Or } T_{\text{ext,b}} \dots \quad 6.24$$

Where :

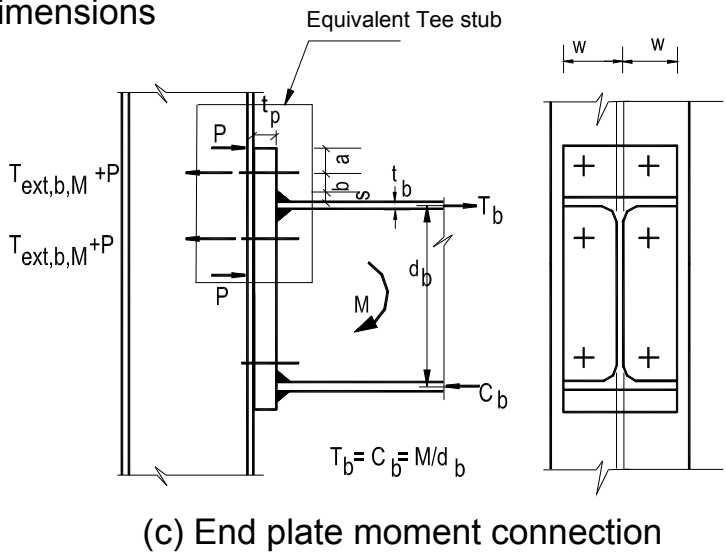
- a,b = Bolt outer overhanging and inner bolt dimension with respect to the stem Tee stub respectively in cm.
- w = Flange Tee stub breadth with respect to one column of bolts.
- A_s = Bolt stress area.
- $T_{\text{ext,b}}$, $T_{\text{ext,b,M}}$ = Applied external tension force on one bolt column due to either an applied external tension force T_{ext} (Fig. 6.10a) or due to the replacement of the applied moment (M) by two equal external and opposite forces $T_b = C_b = \frac{M}{d_b}$ (Fig. 6.10b) or due to an exact analysis of an end plate moment connection (Fig. 6.10c)

Where $T_{\text{ext,b}} = \frac{T_{\text{ext}}}{4}$ (Fig. 6.10a)

$$T_{\text{ext,b,M}} = \frac{T_b}{4} \quad (\text{Fig. 6.10b})$$

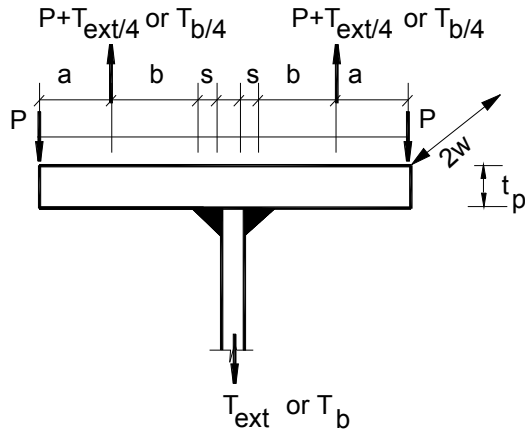


(a) Beam to beam connection in orthogonal dimensions

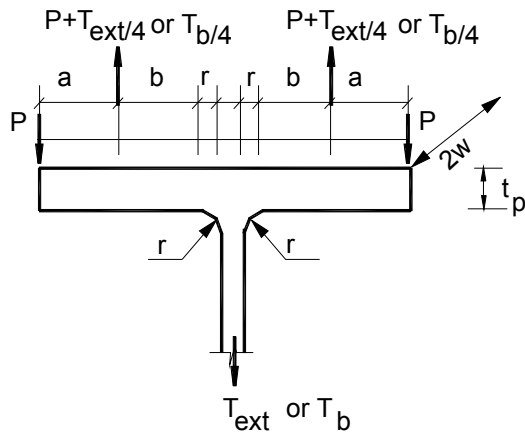


(c) End plate moment connection

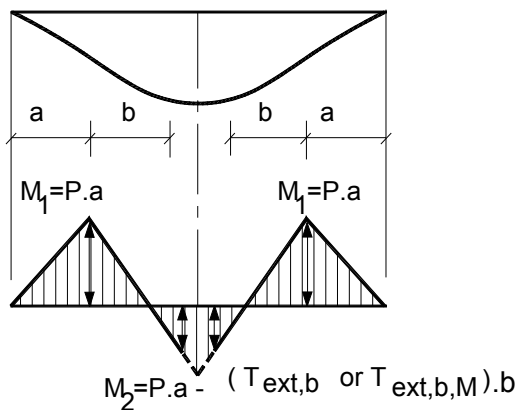
Figure (6.10) Common Types of Connections Producing Prying Forces



(a) Welded flange



(b) Tee- Stub



(c) Deflected Shape

(d) Corresponding Bending Moment

Figure (6.11) Equivalent Tee Stub Connection

6.9.3 Determination of The Tee Stub or The End Plate Thickness

(t_p)

a- The ideal situation shown in Fig. 6.12 is to place the rows of bolts at A-A and B-B as close as possible to the tension flange with not



more than two bolts per row otherwise the uniform distribution of forces can no longer be valid.

b- A row of bolts near the beam compression flange at C-C is to be utilized in order to prevent this part from springing.

c- Compute an approximate end plate thickness using the model shown in (Fig. 6.12b) or using the following relation:

$$t_p = 0.613 \sqrt{\frac{M(2b + 2s + t_b)}{d_b w F_b}} \dots\dots\dots 6.25$$

Where :

- M = Beam moment
- b = Internal distance with respect to the Tee- stub web or to the beam flange.
- s = Fillet weld size.
- t_b, d_b = Flange beam thickness and depth. (d_b = h – t_b)
- h = Height of beam cross section
- F_b = Allowable bending stress of end plate steel material.

d- Compute the induced prying force P using Equation 6.24 where the end plate thickness corresponds to step (c).

e- Compute the exact induced bending moment in the end plate as follows (Fig. 6.12c)

$$\left. \begin{aligned} M_1 &= P.a \\ M_2 &= P.a - T_{ext,b,M} .b \end{aligned} \right\} \dots\dots\dots 6.26$$

f- Hence compute the exact required end plate thickness and the safety of bolts, using the following two Equations:

$$t_p = \sqrt{\frac{6(\text{greater of } M_1 \text{ or } M_2)}{2\bar{w} F_b}} \dots\dots\dots 6.27$$



Where

\bar{w} = Half breadth of end plate = half breadth of Tee-stub flange.

w = \bar{w} for case of two columns of bolts .

$$T_{ext,b,M} + P \leq 0.8 T \quad \dots\dots\dots 6.28$$

6.9.4 Safety Requirements for Beam to Column Connections

i. Column web at the vicinity of the compression beam flange “ crippling of the column web “ :

Crippling of the column web is prevented if :

$$t_{wc} \geq \frac{b_b t_b}{t_b + 2t_p + 5k} \quad \dots\dots\dots 6.29$$

If Equation 6.29 is not satisfied, use a pair of horizontal stiffeners fulfilling the following condition :

$$2b_{st} t_{st} \geq b_b t_b - (t_b + 2t_p + 5k)t_{wc} \quad \dots\dots\dots 6.30$$

In order to prevent the local buckling of these stiffeners:

$$b_{st} / t_{st} \leq 25 / \sqrt{F_y} \quad \dots\dots\dots 6.31$$

ii. Column flange at the location of the tension beam flange “ bending of the column flange “:

Bending of the column flange is prevented if:

$$\dots\dots\dots 6.32$$

If Equation 6.32 is not satisfied, use a pair of horizontal stiffeners fulfilling the condition of Equation 6.30:



iii. Distortion of the web at beam to column connection:

Distortion of the column web is prevented if:

$$t_{wc} \geq (M / d_b) / [(0.35 F_y) h_c] \dots\dots\dots 6.33$$

If Equation 6.33 is not satisfied, use either **a** or **b** :

a- a doubler plate to lap over the web to obtain the total required thickness.

b- a pair of diagonal stiffeners in the direction of the diagonal compression having the following dimensions:

$$2b_{st}t_{st} = [(M / d_b) - (0.35 F_y) h_c t_{wc}] / (0.58 F_y \cos \theta) \dots\dots\dots 6.34$$

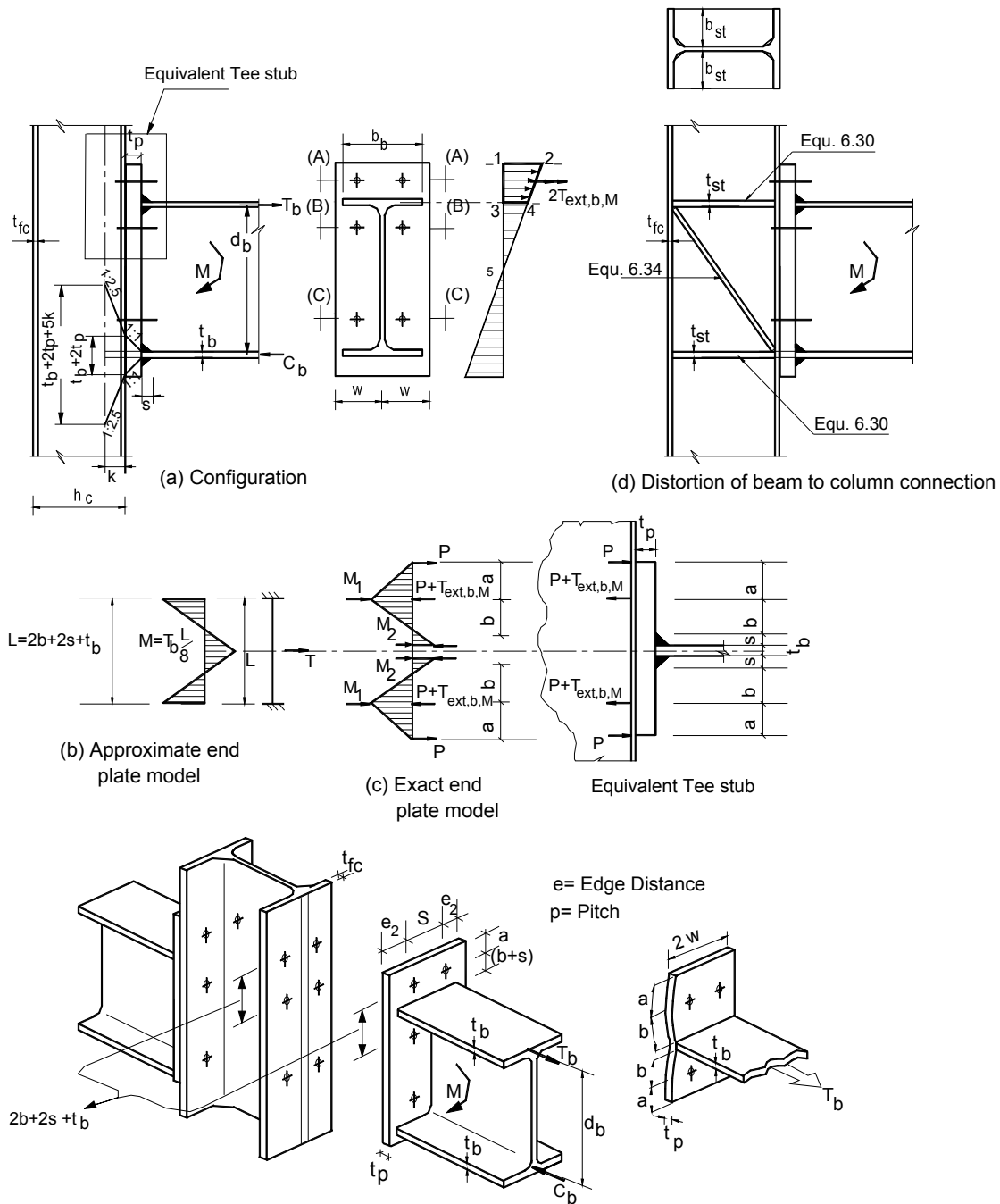


Figure 6.9.
Figure (6.12) Determination of The Tee Stub or The End Plate Thickness (t_p)



CHAPTER 7

PLATE GIRDERS FOR BUILDINGS AND BRIDGES

7.1 GENERAL

Plate girder sections with no-large openings shall be designed using the moment of inertia method. The web height-to-thickness ratio (d/t_w) should not exceed $830/F_y$, where F_y is the yield stress in t/cm^2 , and the minimum thickness of component plate is 5 mm for buildings and 8 mm for bridges.

7.2 ALLOWABLE STRESSES & EFFECTIVE CROSS-SECTIONS

The allowable stresses used for design of plate girder sections are as specified in Clause 2.6. The effective cross-sectional area of slender elements shall be calculated according to Clause 2.6.5.5.

7.3 WEB PLATE THICKNESS

7.3.1 Girders with Transverse Stiffeners

a- Transverse intermediate stiffeners shall be used when the average calculated shear stress in the gross section of the web plate is larger than the value obtained from Equations 2.8, 2.9, and 2.10 with $k_q = 5.34$; i.e.,

$$\begin{aligned}
 & \text{- for } (d/t_w) \leq 159/\sqrt{F_y} \\
 q_b &= [1.5 - (d/t_w) \sqrt{F_y} / 212] [0.35 F_y] \leq 0.35F_y \quad 7.1
 \end{aligned}$$

$$\begin{aligned}
 & \text{- for } (d/t_w) > 159/\sqrt{F_y} \\
 q_b &= \{119 / [(d/t_w) \sqrt{F_y}] \} \{0.35 F_y\} \dots\dots\dots 7.2
 \end{aligned}$$

b- When transverse stiffeners are used, their spacing shall be such that the actual shear stress will not exceed the value given by Equations 2.8, 2.9 and 2.10.



c- If a girder panel is subjected to simultaneous action of shear and bending moment with the magnitude of the shear stress higher than $0.6 q_b$, according to Equations 2.8, 2.9 and 2.10, the allowable bending stress shall be limited to :

$$F_b = [0.8 - 0.36 (q_{act} / q_b)] F_y \dots\dots\dots 7.3$$

Alternatively, the cross section may be designed assuming the flanges alone can resist the total bending moment in the girder without reducing the allowable bending stress.

7.3.2 Girders not Stiffened Longitudinally

a- The web plate thickness of plate girders without longitudinal stiffeners (with or without transverse stiffeners) shall not be less than that determined from:

$$t_w \geq d \sqrt{f_{bc}} / 145 > d/120 \dots\dots\dots 7.4$$

b- Where the calculated compressive stress f_{bc} equals the allowable bending stress F_{bc} , the thickness of the web plate shall not be less than:

$$t_w \geq d \sqrt{F_y} / 190 \dots\dots\dots 7.5$$

Grade of Steel	$t_w \geq$	
	$t \leq 40$ mm	40 mm $< t \leq 100$ mm
St 37	d/120	d/130
St 44	d/110	d/120
St 52	d/100	d/105

7.3.3 Girders Stiffened Longitudinally

a- The web plate thickness of plate girders with longitudinal stiffeners (with or without transverse stiffeners), placed at $d/5$ to $d/4$ from compression flange, shall not be less than that determined from:



$$t_w \geq d \sqrt{f_{bc}} / 240 > d/240 \dots\dots\dots 7.6$$

b- Where the calculated compressive stress f_{bc} equals the allowable bending stress F_{bc} , the thickness of the web plate shall not be less than:

$$t_w \geq d \sqrt{F_y} / 320 \dots\dots\dots 7.7$$

Grade of Steel	$t_w \geq$	
	$t \leq 40$ mm	40 mm $< t \leq 100$ mm
St 37	d/206	d/218
St 44	d/191	d/200
St 52	d/168	d/175

7.4 WEB STIFFENERS

7.4.1 Transverse Stiffeners

i- Intermediate transverse stiffeners, Fig. 7.1, may be in pairs, i.e.; one stiffener connected on each side of the web plate, with a tight fit at the compression flange. They may, however, be made of a single stiffener connected on one side of the web plate.

ii- Bearing stiffeners at points of concentrated loading shall be placed in pairs with tight fit at both flanges, and should be designed as columns on the applied force or reaction at the stiffener position.

iii- The outstand of the stiffeners should not be less than:

- $d/30 + 5$ cm for stiffeners on both sides; or
 - $d/30 + 10$ cm for stiffeners on one side only,
- where d is the web height in cm.

iv- Intermediate transverse stiffeners should be designed to resist a force C_s equal to:



$$C_s = 0.65 \left(\frac{0.35 F_y}{q_b} - 1 \right) Q_{act} \dots\dots\dots 7.8$$

Where:

- Q_{act} = Maximum vertical shear at the stiffener position
- q_b = The buckling shear stress

v- A part of the web equals to 25 times the web thickness and 12 times the web thickness may be considered in the design of the intermediate and the end stiffeners, respectively.

vi- Transverse stiffeners, bearing and/or intermediate should be designed as a column with a buckling length of **0.8d** and meet the requirements of the compression elements given in Chapter 2.

vii- The connection between the transverse stiffener and the web should be designed on the stiffener design force. For intermediate stiffeners, this connection is designed in such a way that the fasteners in either the upper or the lower thirds of the stiffeners should transfer the design force.

7.4.2 Longitudinal Stiffeners

The moment of inertia of the longitudinal stiffener about the axis parallel to the web transverse direction should not be less than:

$4 d(t_w)^3$ for longitudinal stiffeners provided at a distance of **d/5** to **d/4** from the compression flange; and

$d(t_w)^3$ for longitudinal stiffeners provided at the neutral axis of the girder.

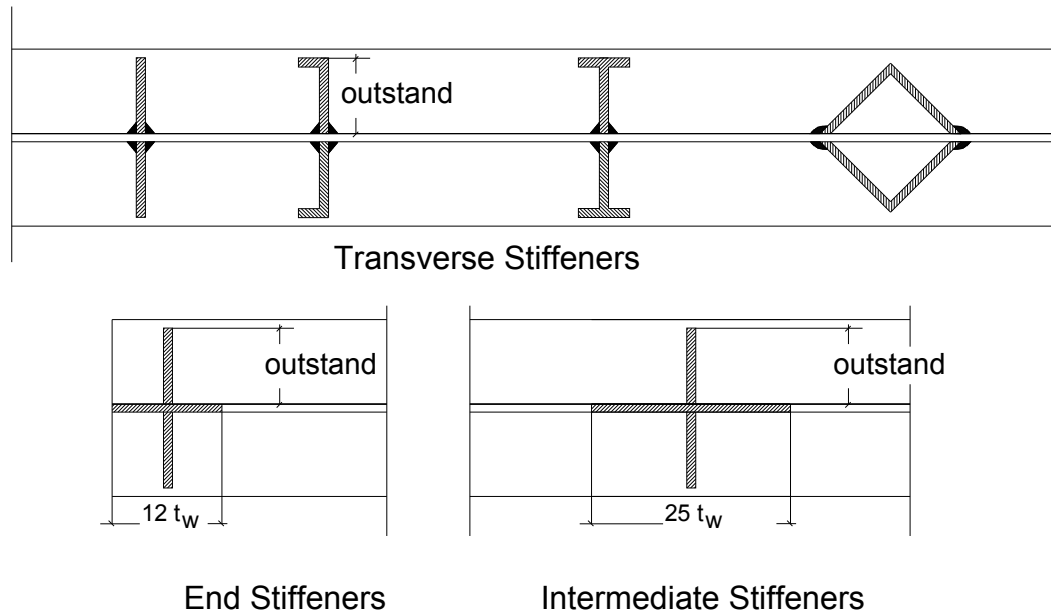


Figure (7.1) Intermediate Transverse Stiffeners

7.5 SPLICES

SplICES should be designed on the maximum bending resistance of the girder section and the actual shearing force at the splice location.

7.6 UNSUPPORTED LENGTH OF COMPRESSION FLANGE

The unsupported length of compression flange of plate girders shall be according to Clause 4.3.4.

7.7 DEFLECTION

The allowable deflection of plate girders shall be according to Clause 9.1.3.



CHAPTER 8

TRUSS BRIDGES

8.1 GENERAL

For triangulated frames designed on the assumption of pin jointed connections, members meeting at a joint should, where practicable, have their centroidal axes meeting at a point; and wherever practicable the center of resistance of a connection shall lie on the line of action of load so as to avoid any moment due to eccentricity on the connection.

Where the design is based on non-intersecting members at a joint, all stresses arising from the eccentricity of the members shall be calculated and the stresses kept within the limits specified in Clause 2.6.7.

The centroidal axes of the different chord sections shall be replaced with an average axis for the whole chord.

Foot or pedestrian bridges shall be designed under the building requirements as given in section 9.2.

8.2 SPACING AND DEPTH OF TRUSSES

The spacing between centers of main trusses should be sufficient to resist overturning with the specified wind pressure and loading conditions, otherwise provision must be specially made to prevent such overturning. In no case, shall this width be less than $1/20$ of the effective span, not less than $1/3$ of the depth. The depth of trusses shall be chosen such that the elastic deflection due to live load without dynamic effect shall not exceed the values specified in Clause 9.1.3.

For simply supported parallel chord trusses, the depth shall preferably be not less than $1/8$ of the span for railway bridges or $1/10$ of the span for roadway bridges.



8.3 MINIMUM THICKNESS

The thickness of elements shall satisfy at least the requirements of non-compact elements as given in Table 2.1.

The minimum thickness of gusset plates and other plates shall be according to Clause 9.1.4.

The critical sections of the gusset plates should be checked to resist safely the forces transmitted to the gusset plates from the web members.

8.4 COMPRESSION MEMBERS

8.4.1 Slenderness Ratios

The maximum slenderness ratios of compression members shall be according to Clause 4.2.1.

8.4.2 Effective Buckling Length ($K\ell$)

The effective buckling length ($K\ell$) of a compression member may be taken from Table 4.5, or obtained from an elastic critical buckling analysis of the truss.

8.4.3 Unbraced Compression Chords

8.4.3.1 For simply supported trusses where there is no lateral bracing between the trusses and no cross frames but with each end of the truss adequately restrained, the effective buckling length ($K\ell$) shall be taken according to Clause 4.3.2.2.

8.4.3.2 For a bridge where the compression chord is laterally restrained by U-frames composed of cross girders rigidly connected to the verticals of the truss, the effective buckling length of the compression chord ($K\ell$) shall be according to Clause 4.3.2.3. The design of such U-frames will be according to Clause 9.3.2.3.



8.4.3.3 For continuous bridges, the effective buckling length of the compression chord (Kl) shall be determined from an elastic critical analysis of the truss.

8.4.4 Depth of Compression Chord Members

Compression chord members shall have a depth in plane of the truss of $1/12 - 1/15$ of the panel length. The maximum depth may be $1/10$ of the panel length; if this value is exceeded, secondary stresses will have to be considered in the design. The recommended width shall be $0.75 - 1.25$ times the depth.

8.4.5 Depth of Compression Web Members

For inclined compression web members the minimum depth in plane of the truss shall be determined to satisfy the buckling and slenderness ratio requirements. The depth may not be more than $1/15$ of the unsupported length for these members; if this value is exceeded, secondary stresses will have to be considered in the design.

8.5 TENSION MEMBERS

8.5.1 Slenderness Ratios

The maximum slenderness ratios of tension members shall be according to Clause 4.2.2.

8.5.2 Effective Area

The properties of the cross section shall be computed from the effective net sectional area, if bolts are used at splices or connections of the member to other members. Effective net area shall be according to Clause 2.7.1.

8.5.3 Depth of Tension Members

For horizontal and inclined tension members the depth in plane of the truss shall not be less than $1/30$ of the unsupported length of these members in railway bridges and $1/35$ of the said length in roadway bridges. The depth shall preferably not be more than $1/10$



of the unsupported length for chord members or $1/15$ of the unsupported length for web members.

8.6 LACING BARS, BATTEN PLATES AND DIAPHRAGMS

In double gusset sections of a truss the two component parts of a member shall be connected together by lacing bars, batten plates and diaphragms. The details of such elements are presented in Chapter 9.

8.7 SPLICES AND CONNECTIONS

Splices in compression or tension members shall be designed on the maximum strength of the member.

Except as otherwise provided, connections for main members shall be designed for a capacity based on not less than the average of the actual force in the member at the point of connection and the maximum strength of the member at the same point but- In any event- not less than 75 % of the maximum strength in the member.



CHAPTER 9

COMPLEMENTARY REQUIREMENTS FOR DESIGN AND CONSTRUCTION

9.1 GENERAL FOR BUILDINGS AND BRIDGES

The following Clauses shall apply equally to buildings and bridges.

9.1.1 Symmetry and Concentricity of Sections

9.1.1.1 All sections shall, as far as possible, be symmetrical about the central plane of girder or truss. Web members shall preferably have two planes of symmetry.

9.1.1.2 All welded, bolted, riveted, or pinned connections should be symmetrically arranged so as to avoid eccentricity as far as possible.

9.1.1.3 Members meeting at a joint should, as a rule, have their center of gravity lines intersecting at a point.

9.1.1.4 If connected on one side of a gusset plate, the effective area of sections in tension shall be taken as given in Clause 9.2.2.3 .

9.1.2 Combined Use of Mild Steel and High Tensile Steel (Hybrid Sections)

Ordinary grade steel and high tensile steel may be used jointly in a structure or in any member of a structure provided that the maximum stress in each element does not exceed the appropriate permissible stress.

9.1.3 Deflection of Beams, Portal Frames and Trusses

The calculated deflection due to live load only without dynamic effect of any beam or truss shall not be greater than the values shown in Table 9.1. The deflection shall not, however, be such as to impair the strength or efficiency of the structure or lead to damage to the finishings.

Table (9.1) Maximum Deflection in Buildings and Bridges

Member	Max. Deflection
Beams and trusses in buildings carrying plaster or other brittle finish	L/300
All other beams	L/200
Cantilevers	L/180
Horizontal deflection at tops of columns in single-storey buildings other than portal frames	Height / 300
Horizontal deflection in each storey of a building with more than one storey	Height of storey under consideration / 300
Horizontal deflection at the top of a building with more than one storey	Total height of building / 500
Horizontal deflection at tops of columns in portal frames without gantry cranes	Height / 150
Horizontal deflection at tops of columns in portal frames with gantry cranes	To be decided according to the recommendations of the gantry crane manufacturer, but should not exceed the height / 150
Crane track girders	L/800
Railway bridges	L/800
Roadway bridges	L/600
Overhanging portions of bridges	L/300

Where L is the span.



9.1.4 Minimum Thickness of Plates

The minimum thickness (in mm) to be used in structural steelwork (except cold-formed steel sections) shall be as given in the following Table.

Sections	Railway Bridges	Roadway Bridges	Buildings
-Plates	8	8	5
-Gusset plates for main trusses	12	10	8

An addition shall be made to the sectional areas required to resist the computed stress, so as to allow for corrosion, when climate influences or other conditions may set up such a corrosion or when the steelwork is not accessible for painting on both sides. In such cases the minimum thickness as given above shall be increased by at least 1 mm.

9.1.5 Lacing Bars, Batten Plates and Diaphragms

9.1.5.1 Lacing of Compression Members

As far as practicable, the lacing system shall not be varied throughout the length of the compression member.

Lacing bars shall be inclined at an angle of 50° to 70° to the axis of the member where a single intersection system is used and at an angle of 40° to 50° where a double intersection system is used.

Lacing bars shall be connected such that there will be no appreciable interruption of the triangulation of the system.

The maximum unsupported length of the compression member between lacing bars (l_z) whether connected by welding, bolting or riveting, shall be such that the slenderness ratio of each component



part between consecutive connections (l_z/r_z) shall not be more than 50 in bridges and 60 in buildings or $2/3$ times the slenderness ratio of the member as a whole about the x-x axis, whichever is the lesser.

The required section of lacing bars shall be determined by using the permissible stresses for compression and tension members given in Chapter 2 .

The ratio (kl/r) of the lacing bars shall not exceed 140. For this purpose the effective length (kl) shall be taken as follows:

i- In bolted or riveted connections: the length between the inner end bolts or rivets of the lacing bar in single intersection lacing and 0.7 of this length for double intersection lacing effectively connected at the intersection.

ii- In welded connections: the distance between the inner ends of effective lengths of welds connecting the bars to the components in single intersection lacings, and 0.7 of the length for double intersection lacing effectively connected at the intersection.

Laced compression members shall be provided with batten plates at the ends of the lacing system, at points where the lacing system is interrupted, and where the member is connected to another member.

The length of end batten plates measured between end fastenings along the longitudinal axis of the member shall be not less than the perpendicular distance between the centroids of the main components, and the length of intermediate batten plates shall not be less than $3/4$ of this distance, see Figure 9.1.

The thickness of the plates shall not be less than $1/50$ of the distance between the innermost lines of welds, bolts or rivets.

Batten plates and their fastenings shall be capable of carrying the forces for which the lacing system is designed, (considered as 2% of the force in the member under design).

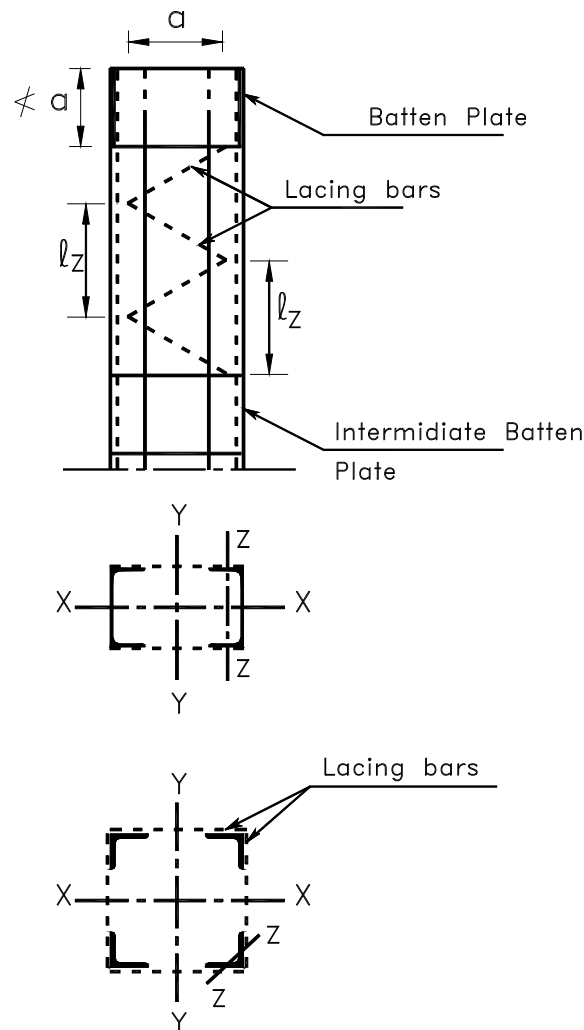


Figure (9.1) Laced Compression Members

9.1.5.2 Battening of Compression Members

The battens shall, as far as practicable, be spaced and proportioned uniformly throughout. The number of battens shall be such that the member is divided into not less than three bays within



its actual center to center of connections. Battens may be plates, channels or other sections.

In battened compression members, the slenderness ratio l_z/r_z of the main component shall not be greater than 50 in bridges and 60 in buildings or $2/3$ times the maximum slenderness ratio of the member as a whole, whichever is the lesser.

The member as a whole can be considered as a vierendeel - girder, or intermediate hinges may be assumed at mid distances to change the system into a statically determinate system. Battens and their connections shall be designed to resist simultaneously a longitudinal shear force = $(Q.d / n.a)$ and a moment = $(Q.d / 2n)$ as shown in Fig. 9.2.

Where :

The longitudinal distance center to center of battens.

The minimum transverse distance between the centroids of welding, bolt groups, or rivets.

The transverse shear force (considered as 2% of the force in the member under design).
e number of parallel planes of battens.

The effective length for each component of the main member between two consecutive battens parallel to the axis of the member shall be taken as the longitudinal distance between the end fasteners, (l_z). End battens shall have an effective length of not less than the perpendicular distance between the centroids of the main components, and intermediate battens shall have an effective length of not less than $3/4$ of this distance, but in no case shall the length of any batten be less than twice the width of the smaller component in the plane of the battens, see Fig. 9.2.

The thickness of batten plates shall be not less than $1/50$ of the minimum distance between the innermost lines of connecting welds, bolts, or rivets.

Battened compression members not complying with these

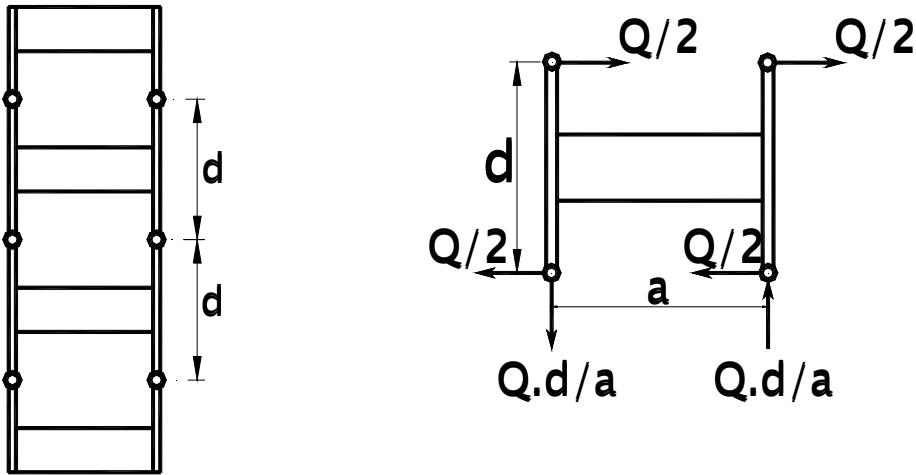
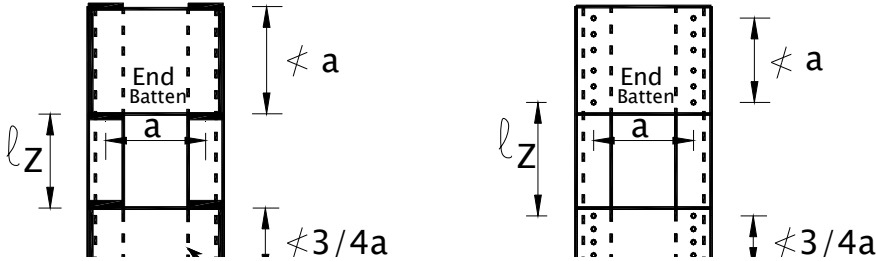


Figure (9.2) Battened Compression Members

9.1.5.3 Equivalent Slenderness Ratio of Battened or



Latticed Compression Members

For battened or latticed compression members, the slenderness ratio ($k\ell$) shall be modified as given below:

a- For buckling in plane (**y-y**) Figure 9.2, the permissible stress for members shall be obtained by using the slenderness ratios and the formulae for solid members given in Chapter 2.

b- For buckling in the plane (**x-x**), the slenderness ratio (ℓ_y/r_y) in these formulae shall be replaced by the values given hereunder.

i. For members with lacing bars and batten plates at their ends:

$$\sqrt{\left(\frac{\ell_y}{r_y}\right)^2 + \left(\frac{\ell_z}{r_z}\right)^2} \dots\dots\dots 9.1$$

ii. For members with batten plates only:

$$\sqrt{\left(\frac{\ell_y}{r_y}\right)^2 + \left(1.25 \frac{\ell_z}{r_z}\right)^2} \dots\dots\dots 9.2$$

Where :

- Unsupported length of each separate part as defined before.
- Radius of gyration for one part for the axis (z-z).

c- Members connected in both directions by lacing bars or batten plates shall be designed similarly by calculating the value indicated in Equations 9.1 and 9.2 for the axis (x-x) or (y-y) giving the smallest moment of inertia for the total section and (r_z) for the axis (z-z) giving the least moment of inertia for one separate part.



9.1.5.4 Diaphragms in Members

Diaphragms are transverse plates or channels connected to the two webs of the box section. They are necessary to ensure the rectangular shape of the box section. In the chords, at least one diaphragm between the two panel points of the member is to be provided. In the diagonals, at least one diaphragm near each end is also to be provided.

In addition to the diaphragms required for the proper functioning of the structure, diaphragms shall be provided as necessary for fabrication, transportation and erection.

9.1.5.5 Lacing or Battening of Tension Members

In double gusset plane trusses, the two component parts of tension members shall be connected together by diaphragms as well as lacing bars or batten plates similar to those of the compression members, but their thicknesses may be reduced by 25 %.

9.1.6 Camber

a. Main girders of bridges more than 15 m in length of truss or plate girder construction shall be provided with such a camber that, under the effect of the dead load and half the live load (without dynamic effect), the said camber shall be taken out by the deflection. Rolled beams and plate girders 15 m or less in length, need not to be cambered.

b. Structural buildings may also be provided with an erection camber, as indicated in the project specifications or the plans.

c. Camber diagrams and fabrication details shall be shown on the project drawings and fabrication details.

d. Camber may be required to maintain clearance under all conditions of loading, or it may be required on account of appearance. Camber may also result from prestressing.



9.2 STEEL BUILDINGS

9.2.1 Depth – Span Ratios

The depth of rolled beams in floors shall preferably be not less than $1/24$ of their span. Where floors are subject to shocks or vibrations, the depth of beams and girders shall preferably be not less than $1/20$ of their span. The depth of simply supported roof purlins shall preferably be not less than $1/40$ of their span. Beams, girders and trusses supporting plastered ceilings and all other beams shall be so proportioned that the maximum deflection due to live load without dynamic effect shall not exceed the values in Clause 9.1.3.

9.2.2 Trusses

Provisions for bridge trusses Chapter 8 shall apply except as otherwise prescribed herein.

9.2.2.1 General

The gross sectional area shall be taken as the area of cross-section as calculated from the specified size.

The net sectional area shall be taken as the gross sectional area less deductions for bolt holes, rivet holes and open holes, or other deductions specified herein.

In taking deductions for bolt and rivets holes, refer to Clause 6.2.2 for details about the excess to the nominal diameter of the bolt or rivet that should be deducted.

For calculation of the effective net sectional area, refer to Clause 2.7.1.



9.2.2.2 Compression Members

In case of compression members unsymmetrically connected to the gusset plate, the effect of eccentricity must be taken into account, see Clause 2.6.4.

9.2.2.3 Tension Members

a. Tension members should preferably be of rigid cross sections, and when composed of two or more components these shall be connected by batten plates or lacing bars.

For horizontal and inclined members, the depth shall be not less than $1/60$ of the unsupported length of these members.

b. The properties of the cross section shall be computed from the effective sectional area.

When plates are provided solely for the purposes of lacing or battening, they shall be ignored in computing the radius of gyration of the section.

c. The effective sectional area of the member shall be the gross sectional area with the following deduction as appropriate:

- i** - Deductions for bolt and rivet holes; Chapter 2.
- ii**- Deductions for members unsymmetrically connected to the gusset plates.

9.2.2.3.1 Effective Area of Unsymmetrical Simple Tension Members

i- Single Angles, Channels and T-sections

For single angle sections connected through one leg only, single channel sections connected only through the web, and T-sections connected only through the flange, the effective area should be taken as the net area of the connected leg, plus the area of the unconnected leg multiplied by:

$$\frac{3A_1}{3A_1 + A_2}$$

9.3

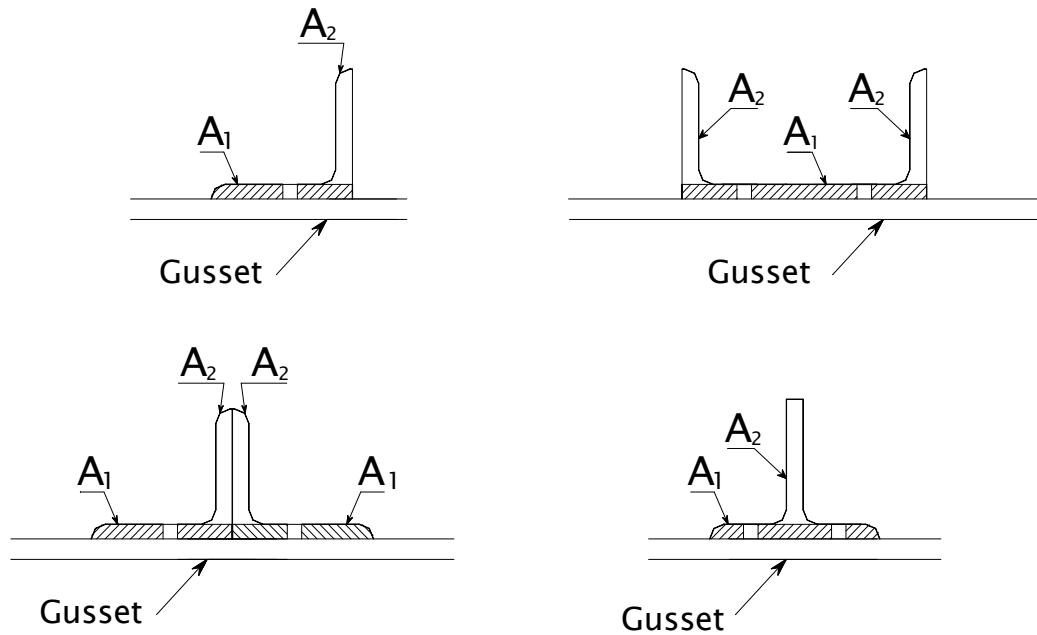


Figure (9.3) Single Angles, Channels and T-Sections Connected to Gusset Plates

Where :

Net area of connected leg.
Area of unconnected leg.

For back to back double angles connected to one side of a gusset or section, the angles may be designed individually as given above.

Where lug angles are used in the connection of single angle the net area of the whole member shall be taken as effective.

ii- Double Angles

For back to back double angles connected to one side of a gusset or section which are:

1. In contact or separated by a distance not exceeding the thickness of the parts with solid packing pieces, or

2. Col
the in

of

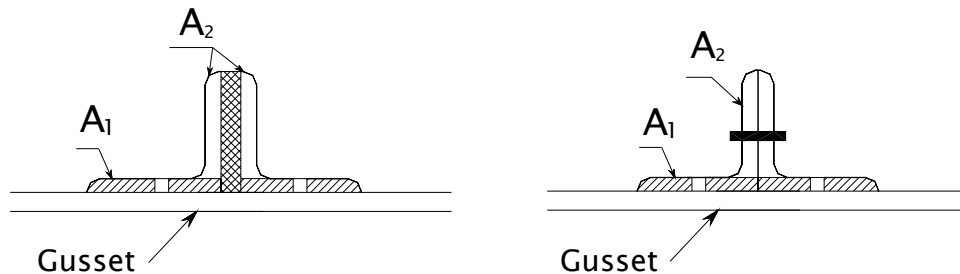


Figure (9.4) Double Angles Connected to Gusset Plates

then the effective area may be taken as the net area of the connected legs plus the area of the outstanding legs multiplied by :

$$\frac{5A_1}{5A_1 + A_2} \dots\dots\dots 9.4$$

Where :

- Net area of connected leg.
- Area of unconnected leg.

9.2.2.4 Connections and Splices

The connections at ends of tension or compression members in trusses shall be designed on the actual forces in the members.

The full splices of members of the section shall be designed on the maximum strength.

9.2.3 Columns and Column Bases

Proper provision shall be made to transfer the column loads and moments, if any, to the foundations.



When the end of the column shaft and the base components are not planed flush, the fasteners connecting them to the base plate shall be sufficient to transmit the forces to which the base is subjected.

Where the end of the column shaft and the base components are planed flush for bearing, not less than 60 % of the transferable load shall be considered as taken by the fasteners.

9.2.4 Bracing Systems

When floors, roofs, or walls are incapable of transmitting horizontal forces to the foundations, the said forces shall be transmitted to the foundation through the steel framework. Triangulated bracing and/or portal construction shall be provided to that purpose.

In buildings where high speed travelling cranes are supported by the structure or where a building may be otherwise subject to vibrations or sway, additional bracing shall be provided to reduce the vibrations or sway to a suitable minimum. Bracing systems have to be provided to support compression members against buckling outside the plane of the frame and to reduce the slenderness ratio of tension chord members.

9.3 STEEL BRIDGES

9.3.1 Bridge Floors

9.3.1.1 Types

Floors of railway bridges may be of the open timber floor type, the ballasted floor type, or the steel plate type with rails directly seated on the steel plate.

Floors of roadway bridges may be constructed of reinforced concrete slab type, the steel plates type or the orthotropic plate type.



9.3.1.2 Floor beams

9.3.1.2.1 General

Floor beams shall be designed with special reference to stiffness by making them as deep as economy or the limiting under clearance will permit.

In the case of rolled steel sections the depth of stringers shall preferably be not less than 1/12 of their span. However, the deflection of such stringers should satisfy the deflection requirements as given in Clause 9.1.3.

The depth of cross girders shall preferably be not less than 1/10 of their span. However, the deflection of such cross girders should satisfy the deflection requirements as given in Clause 9.1.3.

In the calculation of continuous stringers, unless otherwise obtained by a structural analysis, the following bending moments may be assumed:

Positive moment in end span	0.9 M_0
Positive moment in intermediate spans	0.8 M_0
Negative moment at support	0.75 M_0

where M_0 is the maximum bending moment for a simply supported stringer. The same value of bending moment shall be assumed for stringers fitted between cross girders and provided with top and bottom plates resisting the full negative moment at the support. In all other cases, stringers shall be calculated as simply supported beams.

In railway bridges, the ends of deck plate girders and stringers at abutments of skew bridges shall be square to the track, unless a ballasted floor is used.

9.3.1.2.2 Cross Girders

Cross girders shall preferably be at right angles to the main girders and shall be rigidly connected thereto. Sidewalk brackets



shall be connected in such a way that the bending stresses will be transferred directly to the cross girders.

Cross girders over the supports shall be designed to permit the use of jacks for lifting the super structure. For this case, the permissible stresses may be increased by 25 % (see also Clause 2.5 - erection stresses).

9.3.2 Bridge Bracings

9.3.2.1 Lateral Bracings

In all bridges rigid lateral bracing shall extend from end to end, and be capable of transmitting, to the bearings of the bridge, the horizontal forces due to wind pressure, or earthquake load , lateral shock, or centrifugal and braking forces.

Whenever possible, two systems of lateral bracing may be used except in the case of deck spans less than 15 m long, the lower lateral bracing may be omitted. Solid floors may replace the bracing system in its plane.

If the bracing is a double web system and if its members meet the requirement for both tension and compression members, both systems may be considered acting simultaneously. It may be assumed as an approximate solution that both systems equally share the lateral forces. In such case, a further reduction for 20% in the allowable stresses (of bracing members) prescribed in Clause 2.3 shall be made in order to account for that approximation.

The depth of the compression bracing members shall be not less than 1/40 of their unsupported length.

9.3.2.2 Portal Bracing and Intermediate Transverse Bracing

In through bridges having upper and lower lateral bracings, there shall be provided at each end a portal frame capable of transmitting to the bearings, the horizontal reactions of the upper lateral bracing.



In through bridges these portals shall generally be closed frames consisting of the cross girders, the two end posts and an upper girder as deep as possible. In deck bridges end cross frames are used and shall be of the rigid type, either crossed diagonals or Warren type.

In all railway and in road deck bridges there shall be at least two intermediate transverse bracings to increase the stiffness of the bridge. These intermediate transverse bracings are made lighter, in cross section, than the end transverse bracings. Although the intermediate cross frames will release the end cross frames from part of the horizontal reaction of the upper wind bracing, yet it is recommended not to consider that release unless the bridge is treated as a space structure.

9.3.2.3 Lateral Support at Top Chords or Flanges of Through Bridges (Pony Bridges)

In truss bridges without upper lateral bracing and in plate girder pony bridges, the upper chords or flanges shall be laterally elastically supported by an open U-frame consisting of the cross girder and the two posts or stiffeners rigidly connected to each other by bracket plates as large as the specified clearance will allow. These open U-frames shall be designed to resist a horizontal force equal to $1/100$ of the maximum compressive force in the chord acting normal to the compression flange of the girder at the level of the centroid of these flanges. Generally, the U-frames are provided at every panel point or every second panel point.

9.3.2.4 Stringer Bracing and Braking Force Bracing Systems

To avoid lateral bending of stringers and cross girders in railway bridges, bracing systems shall be provided to resist the lateral shock effect and the braking forces. These bracing systems may be omitted in case of solid floors. The stringer bracing shall be provided as near as possible to the upper flanges of the stringers to support these compression flanges against lateral buckling.

Intermediate cross-frames or inverted U-frames may be provided between stringers of long spans to increase lateral stability due to torsion .

The bracing force bracing system may be arranged at each cross girder. In general two bracing force bracing systems at the quarter points of each span are sufficient.

9.3.2.5 Additional Shear for Lateral Bracing

The lateral bracing between compression chords and end posts of trusses and between compression flanges of plate girders shall be designed to resist, in addition to the effect of wind and other applied forces, a cross shear at any section equals to two per cent of the sum of the compression forces at the point considered in the members connected.

9.3.3 Expansion – Bridge Bearings

9.3.3.1 The design of bridges shall be such as to allow for the changes in length of the span, resulting from changes in temperature, live load stresses and small displacements of piers or abutments. A play of at least \pm one cm per 10 m length shall be provided to that effect.

End-bearings shall be so designed as to permit deflection of the main girders without unduly loading the edges of the bearing plates and the face of the abutment or pier.

9.3.3.2 Bearings of bridges of more than 15 m span shall be provided with rollers at the expansion end, except when the span rests on structural steel parts. In this case the structure may be arranged to slide on bearings with smooth curved surfaces, provided the frictional forces are duly accounted for.

Expansion rollers shall be not less than 12 cm in diameter, and the number of rollers shall be either 1, 2, 4, or 6. Rollers with truncated sides (rockers) may be used in special cases only.



All bearings shall be so arranged that they can be readily cleaned.

Rollers shall be coupled together by means of strong side bars and provided with ribs, grooves or flanges so as to ensure their prescribed longitudinal movement and prevent any lateral displacement.

The lower bearing plates shall rest on a 2 to 3 cm thick layer of grout or on a 3 mm sheet of lead and shall be provided with masonry ribs capable of transmitting the horizontal components of the bridge reaction.

9.3.3.3 Modern bearings can be also constructed from new developed materials such as Polytetra Fluoroethylene PTFE, known as Teflon and Synthetic Rubber, known as Neoprene. The design will be according to the specifications of the producer.

9.3.4 Track on Railway Bridges

The fixation of sleepers and rails to the stringers of railway bridges with open floors, shall preferably be as shown in Fig. 9.5 . Rail joints shall be avoided, if practicable, or they should be welded.

For standard-gauge, (1.435m) tracks, the weight of the rails, guard rails, fish plates and bolts, saddle plates, coach screws, attach-plates to sleepers, etc., shall be taken equal to 250 kg/m of track, unless otherwise specified.

The height of rail shall be measured as 15 cm unless otherwise specified.

The sleepers, preferably of oak or American pitch pine, shall be not less than 260 cm long and spaced at not more than 50 cm. Timber sleepers shall be designed on the assumption that the maximum wheel load on a rail is uniformly distributed over two sleepers, and is applied without dynamic effect. Laying of



elastomeric pads between the rails and the sleepers shall be provided for better absorption of impact effects. In ballasted floors, the rails must be levelled and the minimum thickness of ballast under the sleepers should not be less than 20 cm.

The alignment of curved tracks must be perfect. When level differences in the rails are corrected by adding wooden wedges, they present often large ply that must be eliminated. Full sloped wooden sleepers with suitable super elevation must be used.

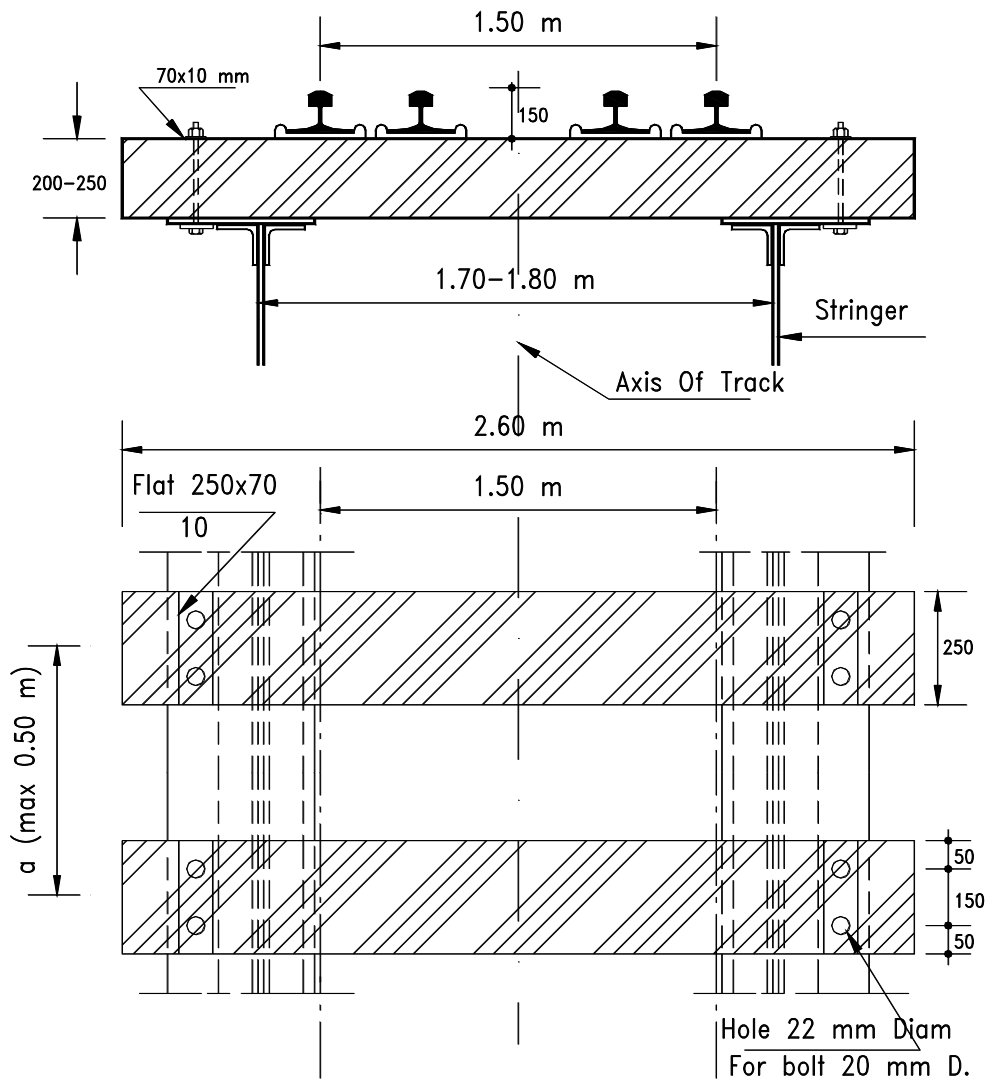


Figure (9.5) Fixation of Sleepers on Steel Bridges



CHAPTER 10

COMPOSITE STEEL – CONCRETE CONSTRUCTION

This Chapter applies to steel beams supporting concrete slabs that are interconnected such that they act together to resist bending. Provisions included herein apply to simple and continuous composite beams constructed with or without temporary shoring. Composite beams must be provided with shear connectors, or else completely encased in concrete.

This Chapter also applies to column and beam-column composite members composed of rolled or built-up structural steel shapes encased in concrete or tubing filled with concrete.

10.1 COMPOSITE BEAMS

10.1.1 Scope

This section deals with simply supported and continuous beams used in buildings and roadway bridges. It is related to beams composed of either rolled or built-up steel sections, with or without concrete encasement acting in conjunction with an in-situ reinforced concrete slab. The two elements are connected so as to form a composite section acting as one unit. Figure 10.1 shows some common cross-sections of composite beams.

10.1.2 Components of Composite Beams

10.1.2.1 Steel Beam

All steel parts used in the composite beams shall comply with their relevant specifications. The steel beam may be a rolled section, a rolled section with a cover plate attached to the tension flange, a plate girder, or a lattice girder. Composite construction is more economic when the tension flange of the steel section is larger than the compression flange. The compression flange of the steel

beam and its connection to the web must be designed for the shear flow calculated for the composite section.

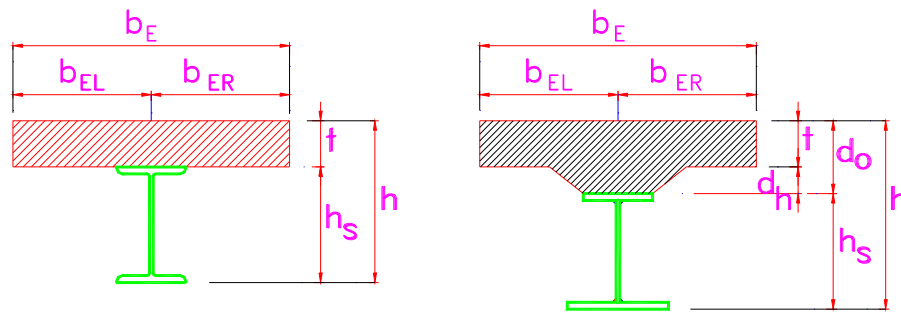


Figure (10.1) Common Cross-Sections of Composite Beams

During construction, the compression flange must satisfy local buckling and lateral torsional buckling requirements as per Clause 2.6.1 and Clause 2.6.5.2, respectively. After construction, however, the composite section shall be exempt from such requirements.

10.1.2.2 Concrete Slab

The concrete used for composite construction shall comply with the current Egyptian Code of Practice for the Design of Reinforced Concrete Structures. The minimum accepted value for the characteristic cube concrete strength, f_{cu} , is 250 kg/cm² for buildings and 300 kg/cm² for bridges. For deck slabs subjected directly to traffic (without wearing surface), the value of f_{cu} shall not be less than 400 kg/cm².

The slab may rest directly on the steel beam or on a concrete haunch to increase the moment of inertia of the composite section. It is also possible to use a formed steel deck with the deck ribs oriented parallel or perpendicular to the steel beam. The concrete slab may also be prestressed.

10.1.2.3 Shear Connectors

Since the bond strength between the concrete slab and the steel



beam is not dependable, mechanical shear connectors must be provided.

They are fastened to the top flange of the steel beam and embedded in the concrete slab to transmit the longitudinal shear and prevent any slippage between the concrete slab and the steel beam. Furthermore, they prevent slab uplift.

There are several types of the shear connectors such as: anchors, hoops, block connectors (including: bar, T-section, channel section, and horseshoe), studs, channels, and angle connectors as will be discussed in details in Clause 10.1.7.

10.1.3 Methods of Construction

Two different methods of construction are to be considered:

10.1.3.1 Without Shoring (Case I)

When no intermediate shoring is used under the steel beams or the concrete slab during casting and setting of the concrete slab, the steel section alone supports the dead and construction loads. The composite section supports the live loads and the superimposed dead loads (flooring, walls, etc.) after the slab has reached 75% of its required characteristic strength, f_{cu} .

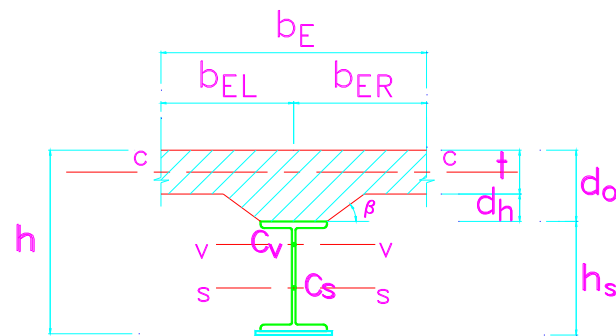
10.1.3.2 With Shoring (Case II)

When an effective intermediate shoring system is utilized during casting and setting of the concrete slab, the composite section supports both the dead and live loads. Shoring shall not be removed until the concrete has attained 75% of its required characteristic strength, f_{cu} .

10.1.4 Design of Composite Beams

Design of composite beams is based on the transformed section concept. Both steel and concrete are considered to be acting as one unit.

10.1.4.1 Span to Depth Ratio



- s-s Central axis of steel section.
- c-c Central axis of concrete slab (neglecting haunch).
- v-v Central axis of composite section.

Figure (10.2) Section Dimensions and Notations

10.1.4.2 Thickness of Concrete Slab

- **For Buildings**

The minimum concrete slab thickness is as follows:

- * For roof slabs $t \geq 8.0$ cm
- * For repeated floors $t \geq 10.0$ cm
- * For floors supporting moving loads (e.g., garages) $t \geq 12.0$ cm

Slabs can be provided with haunches inclined with a slope not steeper than 1:3 ($\tan \beta \leq 3$, Fig. 10.3). The height of the haunch proper, d_h , is normally chosen not more than one and a half times the slab thickness, t . In addition, the total depth, h , of the composite section is normally chosen not greater than two and a half times the depth of the steel beam, h_s .



- **For Roadway Bridges:**

The thickness of the deck slab shall not be less than 16 cm. If the slab is subjected directly to traffic with no wearing surface, the minimum thickness shall be 20 cm.

10.1.4.3 Effective Width of Concrete Slab

a- For Buildings

The effective width $2b_e$, Fig. 10.4, shall be taken the least of:

- 1- $(L/4)$.
- 2- Spacing between girders from center to center.
- 3- $12t_{\text{slab}} + b_{\text{flange}}$.

where L is the actual span between the supports.

Where adjacent spans in a continuous beam are unequal, the value of b_e to be used for calculating bending stress and longitudinal shears in the regions of negative bending moments shall be the mean of the values obtained for each span separately.

b- For Bridges

The effective width b_e of the concrete flange on each side of the center line of the steel beam shall be taken as the actual width b for values of b not exceeding $L/20$ of the span of the beam where b is either half the distance from the center line of the beam to the center line of the adjacent beam or the distance from the center line of the beam to the edge of the slab where there is no adjacent beam, Fig. 10.4.

In cases where b_1 , is different from b_2 , then the effective width b_{e1} will be different from b_{e2} .

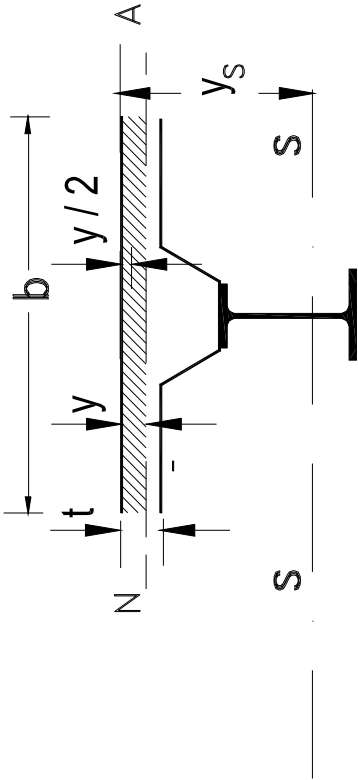


Figure (10.3) Dimensions of Haunches

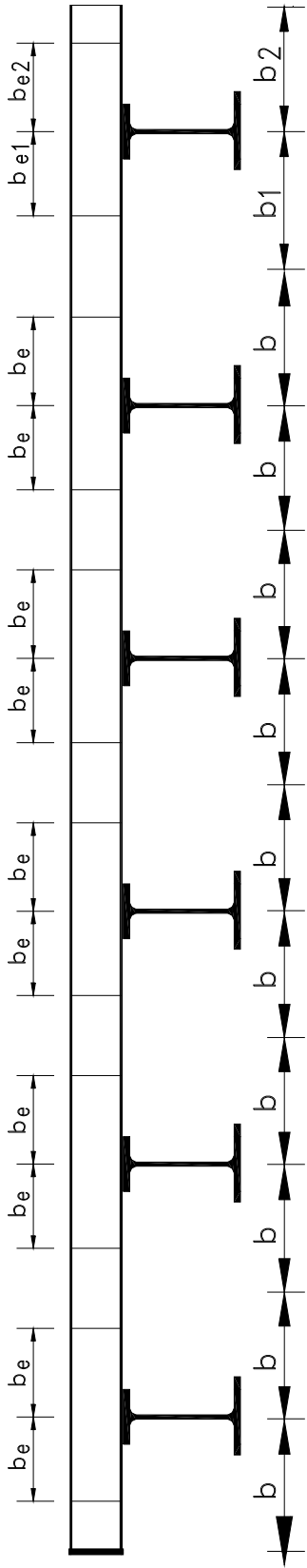


Figure (10.4) Effective Width of Concrete Flange



For values of **b** greater than **L/20** of the span, the effective width on each side of the center line of the steel beam shall be calculated from the formula:

$$b_e = \frac{b}{\sqrt{1 + 12\left(\frac{2b}{L}\right)^2}} \dots\dots\dots 10.1$$

But shall not be taken less than **L/20**.

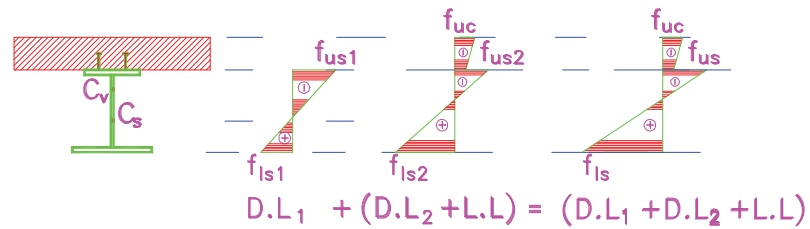
10.1.4.4 Calculation of Stresses

According to the working stress design method, the composite beam shall be transformed to an equivalent virtual section using the modular ratio, **n**. The value of **n=E_s/E_c** may be taken as the nearest whole number (but not less than 7). Table 10.1 lists the recommended values of **n** for some grades of concrete.

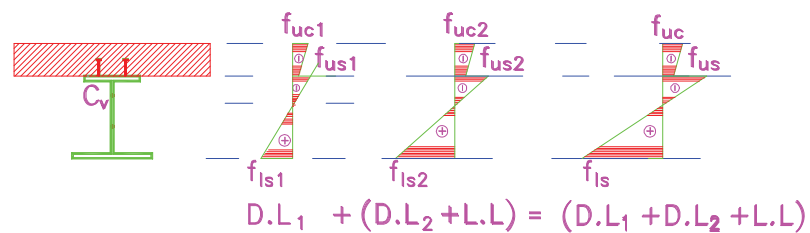
Table (10.1) Recommended Values of the Modular Ratio (n)

Concrete Characteristic Cube Strength, f_{cu} (kg/cm ²)	Modulus of Elasticity of Concrete, E_c (t/cm ²)	Modular Ratio, n
250	220	10
300	240	9
400	280	8
≥ 500	310	7

Bending stresses in the composite section (steel beam, concrete slab, and longitudinal reinforcement) shall be calculated in accordance with the elastic theory, ignoring concrete in tension and assuming no slippage between the steel beam and concrete slab. Figure 10.5 illustrates the distribution of bending stresses for composite beams constructed with or without shoring.



(a) Without Shoring (Case I)



(a) With Shoring (Case II)

D.L₁ = Dead Loads, D.L₂ = Super Imposed Dead Loads
L.L. = Live Loads

Figure (10.5) Stress Distribution

Maximum bending stresses in the steel section shall comply with Clause 2.6 except that the compression flange connected to the reinforced concrete slab shall be exempt from local and lateral buckling requirements. Whereas maximum bending stresses in the concrete slab shall not exceed the allowable limits permitted by the Egyptian Code of Practice for the Design of Reinforced Concrete Structures.

The steel web alone shall resist the vertical shear stresses of the composite beam, neglecting any concrete slab contribution.

10.1.4.5 Stress in Concrete Slab

The design of the concrete slab shall be carried out according to the latest edition of the Egyptian Code of Practice for the Design of

Reinforced Concrete Structures. If the section is in the positive moment zone, and where the neutral axis falls inside the concrete slab, the tensile stresses thus created in the concrete must not exceed the values listed in Table 10.2.

Table (10.2) Allowable Tensile Stress for Concrete

Concrete Characteristic Cube Strength, f_{cu} , kg/cm ²	250	300	400	≥ 500
Tensile Stress, kg/cm ²	17	19	23	27

If the tensile stress in concrete exceeds the above limits, cracks will initiate and the concrete in this zone shall not be considered in the calculation of the composite section inertia.

If in the zone of positive moment, the neutral axis falls inside the concrete slab, the tensile stresses thus created in the concrete must not exceed the maximum allowable stress of the used concrete otherwise the longitudinal shear stresses will not be efficiently transmitted to the dowels.

The neutral axis is to be calculated from the following formula if the cooperation of concrete in tension is neglected (Fig. 10.6).

$$y' = \frac{nA_s}{b_E} \left(\sqrt{1 + \frac{2b_E y_s}{nA_s}} - 1 \right) \dots\dots\dots 10.2$$

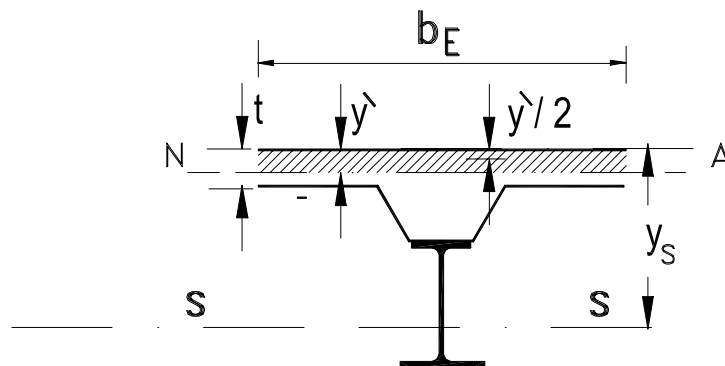


Figure (10.6) Calculation of the Neutral Axis



10.1.4.6 Continuous Beams

The composite construction of continuous beams makes it possible to further reduce the depth and deflection of the beams. Three methods may be adopted to design the section of the continuous beam at intermediate supports (i.e., zones of negative bending moments):

- a-** Steel section alone may be designed to support all loads, dead and live.
- b-** Steel reinforcement within the concrete slab effective width and extending parallel to the beam span, with an adequate anchorage length in accordance with the provisions of the Egyptian Code of Practice for the Design of Reinforced Concrete Structures, may be used as a supplementary part of the steel section. In such a case, shear connectors must be extended above supports.
- c-** Composite section may be designed to support all loads, dead and live, provided that tensile stresses in the concrete slab shall not exceed values listed in Table 10.2.

In the negative moment regions, the lower flange of the steel beam shall be checked against lateral and local buckling provisions according to Clause 2.6.5.5. The point of contraflexure may generally be treated as a brace point.

10.1.4.7 Deflections

If the construction is shored during construction, Case II, the composite section will support both the dead load and the live load deflections. However, if the construction is not shored, Case I, the total deflection will be the sum of the dead load deflection of the steel beam and the live load deflection of the composite section. Deflection allowable limits shall follow the requirements of Clause 9.1.3.



10.1.4.8 Design for Creep and Shrinkage

If shoring provides support during the hardening of concrete, i.e., Case II, the total deflection will be a function of the composite section properties. Account must be taken of the fact that concrete is subject to creep under long-time loading (i.e., dead load) and that shrinkage will occur. This inelastic behavior may be approximated by multiplying the modular ratio, n , by a factor of two. The result is a reduced moment of inertia for the composite section, which is used in computing the dead load deflections and stresses. When the live loads are expected to remain for extended periods of time, such as storage structures and garages, the conservative approach is to use the reduced composite moment of inertia (i.e., using $2n$ instead of n).

For roadway bridges, one third of the concrete modulus of elasticity, $E_c/3$ instead of E_c (i.e., using $3n$ instead of n) shall be used in computing sustained load creep deflections and stresses.

If construction is without shoring, Case I, and live loads are not of the prolonged type, creep effect may be neglected.

10.1.4.9 Design for Temperature Effect

The variation of temperature shall be assumed according to the Egyptian Code of Practice for Calculating Design Loads and Forces on Structures. In general, a 30°C uniform variation of the overall temperature of the structure is assumed. Due consideration shall be given for the fact that although the coefficient of thermal expansion for both steel and concrete is identical, the coefficient of thermal conductivity of concrete is only about 2% of that of steel. Therefore the top of the concrete slab and other levels through the depth of the beam shall be assumed as shown in Fig. 10.7c.

10.1.5 Concrete Slab Edges

Concrete slab edges shall be provided with end closures, e.g., channels, angles, or plates, as shown in Fig. 10.8. End closures have to be fixed to the steel beams before casting the concrete slab.

Besides minimizing grout loss during casting of concrete, end and also

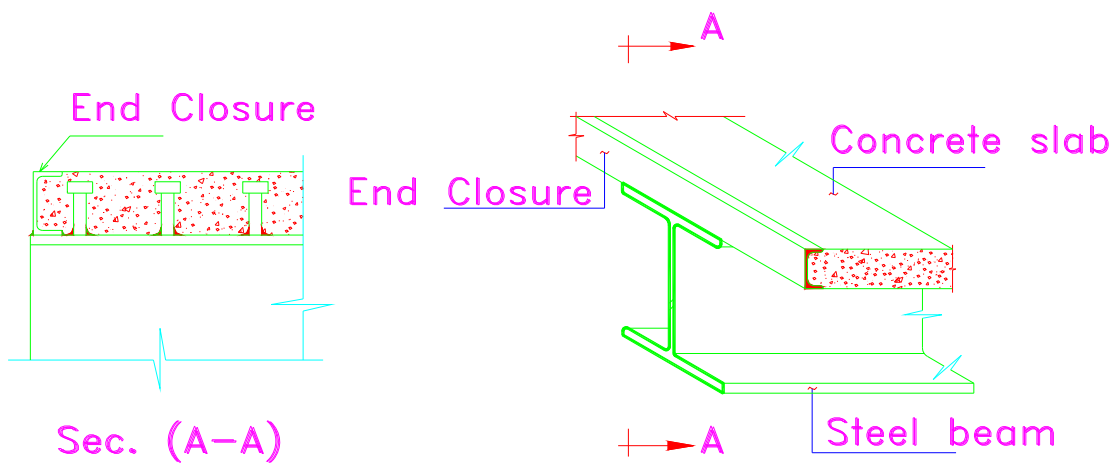
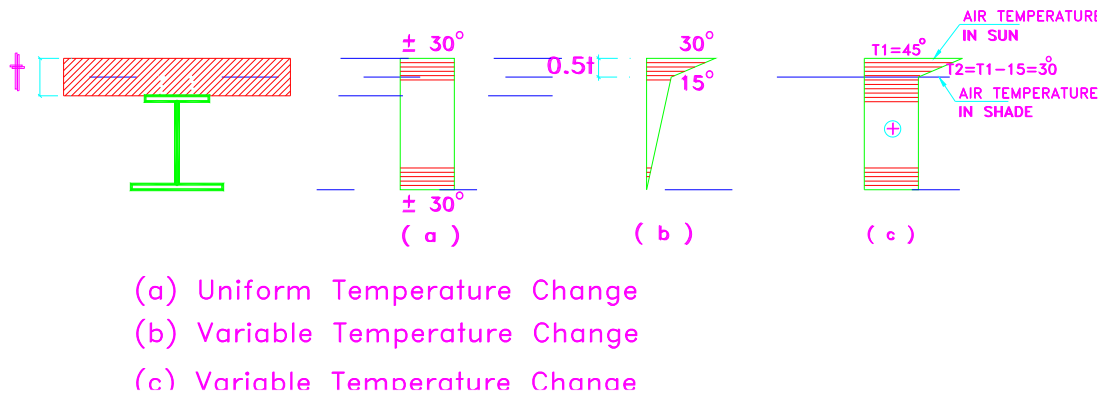


Figure (10.8) End Closure for Concrete Slab

10.1.6 Design of Encased Beams

A beam totally encased in concrete cast integrally with the slab, as shown in Fig. 10.9, may be assumed to be interconnected to the concrete by natural bond, without additional anchorage, provided that:

- a-** Concrete cover over the beam sides, top and bottom flange is at least 40 mm.
- b-** Top flange of the beam is at least 50 mm above the bottom of the slab.
- c-** Concrete encasement contains adequate mesh or other reinforcing steel throughout the whole depth to prevent spalling of the concrete.

Prior to hardening of the concrete, the steel section alone must be proportioned to support all dead and construction loads according to Clause 2.6.5.

After hardening of the concrete the completely encased steel beam is restrained from both local and lateral torsional buckling. Two alternatives can be used for the design in this case:

- a-** The composite section properties shall be used in calculating bending stresses, neglecting concrete in tension.
- b-** The steel beam alone is proportioned to resist the positive moment produced by all loads, live and dead, using an allowable bending stress of $0.72 F_y$, neglecting the composite action.

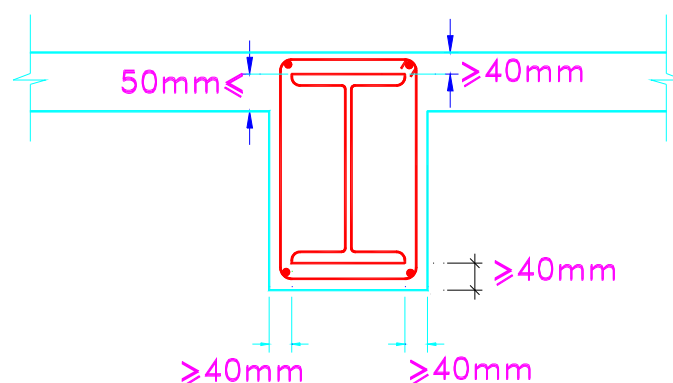


Figure (10.9) Encased Beam



10.1.7 Shear Connectors

Except for totally encased beams, the horizontal flexural shear force at the interface between the concrete slab and the steel beam shall be transferred by shear connectors, as shown in Fig. 10.10 to Fig. 10.12, throughout simple spans and positive moment regions of continuous beams. In negative moment regions, shear connectors shall be provided when the reinforcing steel embedded in the concrete is considered as part of the composite section or when the concrete tensile stresses do not exceed allowable values listed in Table 10.2.

10.1.7.1 Horizontal Shear Force

Shear connectors shall be designed to transfer the horizontal shear flow between the steel and concrete. The spacing between shear connectors, e the pitch, shall be determined such that the connector shall transfer the shear flow along the distance e . However, in buildings, in regions of positive moment, the average spacing between shear connectors can be used.

10.1.7.1.1 Size and Spacing of Connectors

The longitudinal spacing of the connectors shall not be greater than **60** cm or three times the thickness of the slab, or four times the height of the connector, including hoop if any, whichever is the least.

The minimum concrete cover above the top of the connector shall not be less than **5** cm.

10.1.7.1.2 Design of Pitch of Connectors

If the dead load stresses are carried by the steel section, shear connectors may be designed to carry shearing forces due to live loads only. However, to allow for the effects of shrinkage and creep and to give better security against slip, it is recommended to load the connectors by half the dead and the full live load shear stresses.



Longitudinal shearing force per one cm. length of beam equals:

$$Q A_c y_c / I_v \dots\dots\dots 10.3$$

Where:

Q = Shear force.

A_c = Area of the concrete section without haunches.

y_c = Distance between central axis of the concrete section and that of the composite section.

I_v = Moment of inertia of the composite section about its central axis.

Total horizontal shear to be transmitted by one connector along an interval or pitch e :

$$= (Q A_c y_c e) / I_v = D$$

$$e = D (I_v / Q A_c y_c) \dots\dots\dots 10.4$$

Thus the pitch e is inversely proportional to Q , and the connectors are to be arranged closer to each other at the supports and at bigger intervals near the middle of the beam.

It is preferable to use shear connectors with relatively small bearing front areas spaced at a relatively small pitch in order to ensure a better dispersion of the pressure in the concrete mass.

10.1.7.2 Requirements of Shear Connectors

10.1.7.2.1 Connection to Steel Flange

The connection between the shear connectors and the beam flange shall be designed to resist the horizontal shear load, acting on the connector; Clause 10.1.7.3.

10.1.7.2.2 Uplift of Concrete Slab



a- Shear connectors shall be capable of providing resistance to uplift of the concrete slab by designing it to support a tensile force perpendicular to the steel flange of at least 10% of the allowable horizontal load, carried by the connector; Clause 10.1.7.3. If necessary, shear connectors shall be provided with anchoring devices.

b- The surface of the connector that resists separation forces (i.e., the inside of a hoop or the underside of a head of a stud) shall extend not less than 40 mm clear above the bottom reinforcement of the slab.

10.1.7.2.3 Concrete Cover

a- In order to ensure adequate embedment of shear connectors in the concrete slab, the connector shall have at least 50 mm of lateral concrete cover (Fig. 10.3). On the other hand, the minimum concrete cover on top of the connector shall not be less than 20 mm.

b- Except for formed steel slabs; the sides of the haunch should lie outside a line drawn at a maximum of 45° from the outside edge of the connector. The lateral concrete cover from the side of the haunch to the connector should not be less than 50 mm (Fig. 10.3).

10.1.7.2.4 Reinforcement in Concrete Slab

Reinforcement in the slab shall be designed as per the Egyptian Code of Practice for the Design of Reinforced Concrete Structures to avoid longitudinal shear failure or splitting of the slab at the edge of the steel beam upper flange.

10.1.7.2.5 Placement and Spacing

In buildings only, shear connectors required at each side of the point of maximum bending moment, positive or negative, may be

distributed uniformly between that point and the adjacent points of zero moment. However, the number of shear connectors between concentrated loads and the nearest point of zero moment shall be sufficient to develop the required horizontal shear between the concrete slab and the steel beam.

Except for stud connectors, the minimum center to center spacing of shear connectors shall not be less than the total depth of the slab including haunch, d_o . The maximum center to center spacing of connectors shall not exceed the least of the following:

- 60 cm
- Three times the total slab thickness (d_o)
- Four times the connector height including hoops or anchors, if any.

However, the maximum spacing of connectors may be exceeded over supports to avoid placing connectors at locations of high tensile stresses in the steel beam upper flange.

10.1.7.2.6 Dimensions of Steel Flange

The thickness of steel flange to which the connector is fastened shall be sufficient to allow proper welding and proper transfer of load from the connector to the web plate without causing local failure or excessive deformations. The distance between the edge of a connector and the edge of the flange of the beam to which it is welded should not be less than 25 mm (Fig. 10.3).

10.1.7.2.7 Anchors and hoops

a- Anchors and hoops (Fig. 10.10) designed for longitudinal shear should point in the direction of the diagonal tension. Where diagonal tension can occur in both directions, connectors pointing in both directions should be provided.

b- Hoop connectors (diameter = ϕ) shall satisfy the following (Fig. 10.10):

$$r \geq 7.5\phi$$

$$L \geq 4r$$

$$\text{concrete cover} \geq 3\phi$$

c- Development length and concrete cover of anchors shall be based on the allowable concrete bond stresses as per the Egyptian Code of Practice for the Design of Reinforced Concrete Structures.

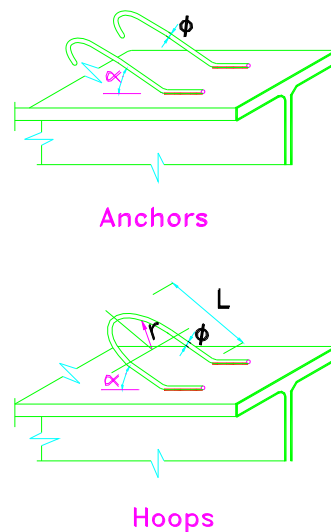


Figure (10.10) Anchor & Hoop Shear Connectors

10.1.7.2.8 Block Connectors

a- Block connectors (Fig. 10.11) shall be provided with anchoring devices to prevent uplift of concrete slab.

b- The height of bar connectors shall not exceed four times its thickness.

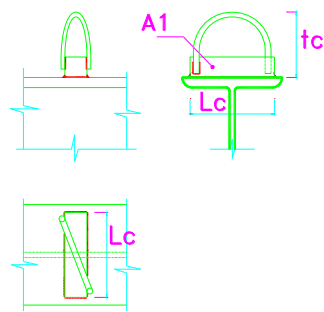
c- The height of T-sections shall not exceed ten times the flange thickness or 150 mm, whichever is the least.

d- Channel sections shall be hot rolled with a web width not exceeding 25 times the web thickness. The height of the connectors shall not exceed 15 times the web thickness nor 150 mm, whichever is the least.

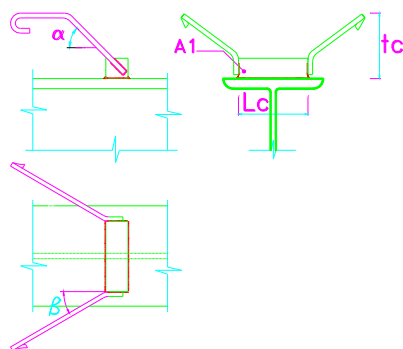
e- The height of horseshoe connectors shall not exceed 20 times the web thickness nor 150 mm, whichever is the least.

10.1.7.2.9 Stud Connectors

The length of the stud connectors shall not be less than four times its diameter, d_s , after installation. The nominal diameter of the stud head shall not be less than one and a half times the stud diameter, d_s (Fig. 10.12). The value of d_s shall not exceed twice the thickness of the top flange of the steel beam.

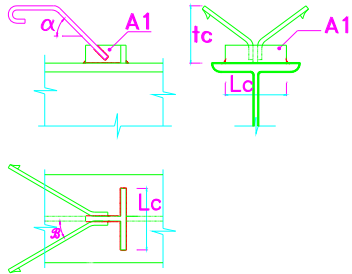


Block Connector with hoop

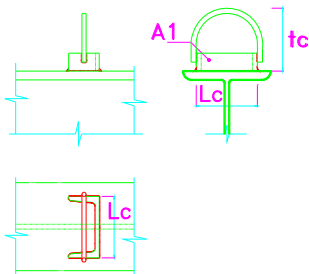


Block Connector with anchor

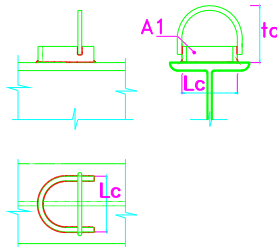
Figure (10.11) Block Shear Connectors



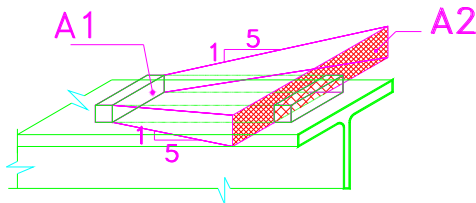
T-section with anchor



Channel section with hoop

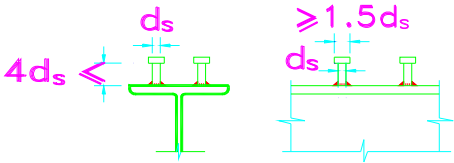


Horseshoe connector with hoop

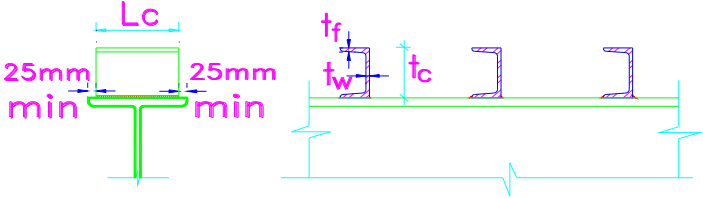


Definition of area (A2)

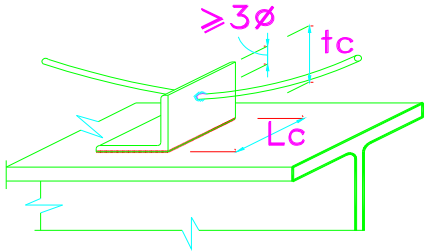
Figure (10.11) Block Shear Connectors (Cont.)



(a) Stud Connectors



(b) Channel Connectors



(c) Angle Connector

Figure (10.12) Stud Shear Connectors

Except for formed steel decks, the minimum center to center spacing of studs shall be $6d_s$, measured along the longitudinal axis of the beam; and $4d_s$, transverse to the longitudinal axis of the supporting composite beam, (Fig. 10.13).

If stud connectors are placed in a staggered configuration, the minimum transversal spacing of stud central lines shall be $3d_s$. Within ribs of formed steel decks, the minimum permissible spacing shall be $4d_s$, in any direction.

10.1.7.2.10 Angle Connectors

The height of the outstanding leg of an angle connector shall not exceed ten times the angle thickness or 150 mm, whichever is the smaller. The length of an angle connector shall not exceed 300 mm (Fig. 10.12).

10.1.7.3 Allowable Horizontal Shear Load for Shear Connectors

This section applies to the calculation of the allowable horizontal shear load, R_{sc} , in tons, for one connector. The value of R_{sc} computed from the following formulas shall not exceed the allowable horizontal load, R_w , provided by the connector connection to the beam flange.

10.1.7.3.1 Anchors and Hoops

The allowable horizontal load for each leg of anchors and hoops satisfying the requirements of Clause 10.1.7.2 shall be computed as follows:

$$R_{sc} = 0.58 A_s F_{ys} \cos \beta / (1 + \sin^2 \alpha)^{1/2} \leq R_w \quad \dots \quad 10.5$$

Where:

- R_{sc} = Allowable horizontal load per connector in tons.
- A_s = Cross-sectional area of anchor or hoop, cm^2 .
- F_{ys} = Yield stress of anchor or hoop material, t/cm^2 .
- β = Angle in horizontal plane between anchor and longitudinal axis of the beam (Fig. 10.11).
- α = Angle in the vertical plane between anchor or hoop and the beam upper flange (Fig. 10.11).

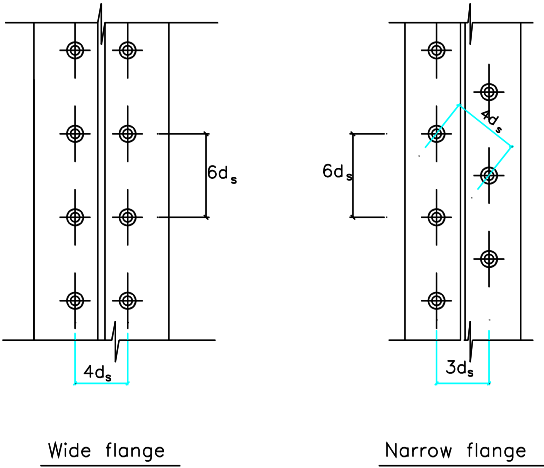


Figure (10.13) Minimum Spacing of Stud Connectors

10.1.7.3.2 Block Connectors

Block connectors such as bar, T-section, channel section, and horseshoe connectors meeting the requirements of Clause 10.1.7.2 can be used as shear connectors. The front face shall not be wedge shaped and shall be so stiff that a uniform pressure distribution on the concrete can be reasonably assumed at failure. The allowable horizontal load (R_{bl} , in tons) transmitted by bearing can be computed from the following Equation:

$$R_{bl} = 0.3 \eta A_1 f_{cu} \times 10^{-3} \dots\dots\dots 10.6$$

Where:

- η = $(A_2/A_1)^{1/2} \leq 2.0$.
- A_1 = Area of connector front face, cm^2 .
- A_2 = Bearing area on concrete, in cm^2 , and shall be taken as the front area of the connector, A_1 , enlarged at a slope of 1:5 (see Fig. 10.11) to the rear face of the adjacent connector. Only parts of A_2 falling in the

concrete section shall be taken into account.

f_{cu} = Characteristic compressive cube strength of concrete after 28 days, kg/cm².

Block connectors shall be provided with anchors or hoops sharing part of the horizontal load supported by the connector, provided that due account shall be taken of the differences of stiffness of the block connector and the anchors or hoops. The allowable horizontal load per connector can be computed from the following:

$$R_{sc} = R_{bl} + 0.5 R_{an} \leq R_w \quad \dots\dots\dots 10.7$$

and

$$R_{sc} = R_{bl} + 0.7 R_h \leq R_w \quad \dots\dots\dots 10.8$$

Where:

R_{an} = Horizontal load supported by anchor (Clause 10.1.7.3.1)

R_h = Horizontal load supported by hoop (Clause 10.1.7.3.1).

10.1.7.3.3 Stud Shear Connectors

The allowable horizontal load, R_{sc} , in ton, for one stud connector conforming to the requirements stated in Clause 10.1.7.2 shall be computed from the following formula:

$$R_{sc} = 5.4 \times 10^{-3} A_{sc} (f_{cu} E_c)^{1/2} \leq R_w \quad \dots\dots\dots 10.9$$

$$\leq 0.58 A_{sc} F_y$$

Where:

A_{sc} = Cross-sectional area of stud connector, cm².

f_{cu} = Concrete compressive strength, kg/cm².

E_c = Modulus of elasticity of concrete, t/cm².

F_y = The yield stress of stud shear connectors ≥ 3.40 t/cm² and the tensile strength ≥ 4.20 t/cm².

10.1.7.3.4 Channel Shear Connectors

The allowable horizontal load, R_{sc} , for one channel shear connector (Fig. 10.14), conforming to the requirements stated in

Clause 10.1.7.2 shall be computed from the following Equation:

$$R_{sc} = 3.80 \times 10^{-3} (t_f + 0.5t_w) L_c (f_{cu} E_c)^{1/2} \leq R_w \quad 10.10$$

Where:

- t_f = Flange thickness of channel shear connector, cm.
- t_w = Web thickness of channel shear connector, cm.
- L_c = Length of channel shear connector, cm.
- f_{cu} = Concrete compressive strength, kg/cm².
- E_c = Modulus of elasticity of concrete, t/cm².

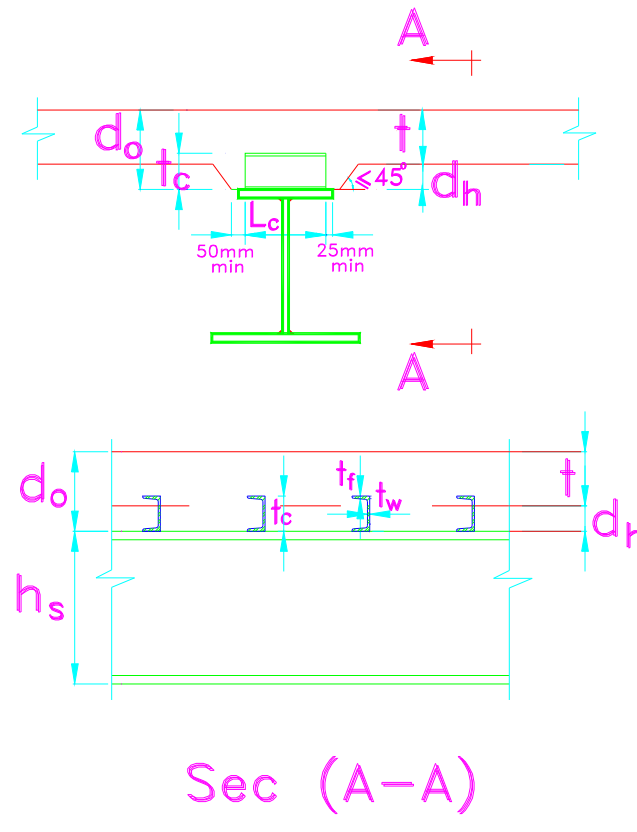


Figure (10.14) Channel Shear Connectors



10.1.7.3.5 Angle Connector

The allowable horizontal load for an angle connector welded to the beam top flange and satisfying the requirements of Clause 10.1.7.2 shall be computed as follows:

$$R_{sc} = 5.6 \times 10^{-3} L_c t_c^{3/4} f_{cu}^{2/3} \leq R_w \dots\dots\dots 10.11$$

Where:

- L_c = Length of angle shear connector, cm.
- t_c = Width of the outstanding leg of angle connector, cm.
- f_{cu} = Concrete compressive strength, kg/cm².
- R_{sc} = Allowable horizontal load per connector, tons.

It is recommended to provide a bar welded to the angle to prevent uplift of the concrete slab, the minimum diameter of the bar shall be computed from the following:

$$\phi \geq 0.45 (R_{sc} / F_{ys})^{1/2} \dots\dots\dots 10.12$$

Where:

- ϕ = Diameter of the bar, cm.
- F_{ys} = Yield stress of the bar, kg/cm².
- R_{sc} = Allowable horizontal load per connector, tons.

The length of the bar on each side of the angle connector's outstanding leg shall be computed based on the allowable bond strength of concrete according to the provisions of the Egyptian Code of Practice for the Design of Reinforced Concrete Structures.

10.2 COMPOSITE COLUMNS

10.2.1 Scope

This section is applied to the design of steel columns fabricated from rolled or built-up steel sections and encased in concrete or

concrete-filled hollow steel pipes or tubing. Typical types of composite columns are illustrated in Fig. 10.15.

10.2.2 Requirements

In order to qualify as a composite column, the following requirements shall be fulfilled:

ian
ed,
ign
of

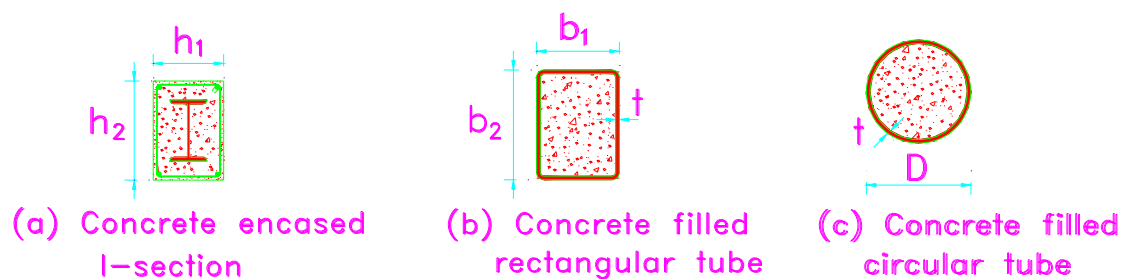


Figure (10.15) Sections for Composite Columns

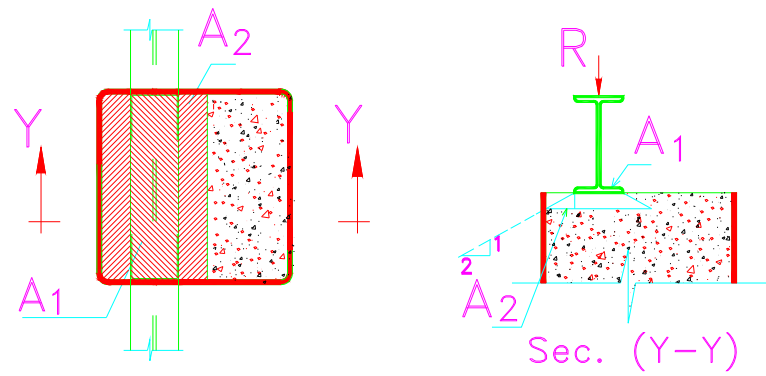
b- The characteristic 28-day cube strength of concrete, f_{cu} , shall not be less than 250 kg/cm^2 , nor greater than 500 kg/cm^2 .

c- Multiple steel shapes in the same cross-section shall be interconnected with lacing, tie plates, or batten plates to prevent buckling of individual shapes before hardening of concrete.

d- Concrete encasement shall be reinforced with longitudinal load carrying bars and lateral ties (stirrups) to restrain concrete and prevent cover spalling. The spacing of lateral ties shall not exceed two thirds of the least dimension of the composite section, or 30 cm, whichever is smaller. The cross-sectional area of lateral ties and longitudinal bars shall be at least 0.02 cm^2 per cm of bar spacing. Concrete cover over lateral ties or longitudinal bars shall not be less than 4 cm.

e- To avoid local buckling, the minimum wall thickness of steel rectangular tubing filled with concrete shall be taken as $b(F_y/3E_s)^{1/2}$ for each face of width b of the tube section. The minimum wall thickness for circular sections of outside diameter, D , shall be taken as $D(F_y/8E_s)^{1/2}$.

f- To avoid overstressing of concrete at connections, the portion of the load carried by the concrete shall not exceed the allowable bearing stress that will be computed as given by the Egyptian Code of Practice for the Design of Reinforced Concrete Structures, Fig. 10.16.



$$F_{app.} = R/A_1 \leq 0.3f_{cu} \sqrt{\frac{A_2}{A_1}}$$

$$\text{where } \sqrt{\frac{A_2}{A_1}} \leq 2.0$$

Figure (10.16) Bearing on Composite Columns at Connections

10.2.3 Design

The allowable compressive axial stress, F_c , for symmetric axially loaded composite columns shall be computed on the steel section area utilizing a modified radius of gyration, yield stress and Young's modulus, r_m , F_{ym} , and E_m respectively, to account for the composite behavior.



For inelastic buckling, $\lambda \leq 100$

$$F_c = (0.58 - \alpha F_{ym} \lambda^2) F_{ym} \dots\dots\dots 10.13$$

For elastic buckling, $\lambda \geq 100$

$$F_c = 3.57 E_m / \lambda^2 \dots\dots\dots 10.14$$

Where:

$$F_{ym} = F_y + c_1 F_{yr} (A_r/A_s) + c_2 f_{cu} (A_c/A_s).$$

$$E_m = E_s + c_3 E_c (A_c/A_s).$$

$$\alpha = (0.58 \times 10^4 F_{ym} - 3.57 E_m) / (10^4 F_{ym})^2.$$

$$f_{cu} = \text{28-day cube strength of concrete.}$$

$$\lambda = \text{Slenderness ratio} = k\ell/r_m.$$

$$K\ell = \text{Buckling length, bigger of in-plane and out-of-plane buckling lengths.}$$

$$r_m = \text{Radius of gyration of the steel shape, pipe or tubing except that for steel shapes encased in concrete it shall not be less than } \mathbf{0.3} \text{ times the overall width of the composite column in the plane of bending.}$$

$$F_{ym} = \text{Modified yield stress, t/cm}^2.$$

$$F_y = \text{Yield stress of steel section, t/cm}^2.$$

$$F_{yr} = \text{Yield stress of longitudinal reinforcing bars, t/cm}^2.$$

$$E_m = \text{Modified Young's modulus, t/cm}^2, \geq E_s.$$

$$E_s = \text{Young's modulus of steel, t/cm}^2.$$

$$E_c = \text{Young's modulus of concrete, t/cm}^2 \text{ (see Table 10.1)}$$

$$A_s = \text{Area of steel section, pipe or tubing, cm}^2.$$

$$A_r = \text{Area of longitudinal reinforcing bars, cm}^2.$$

$$A_c = \text{Area of concrete, cm}^2, \text{ excluding } A_s \text{ and } A_r.$$

$c_1, c_2,$ and $c_3 =$ numerical coefficients taken as follows:

For concrete encased sections,

$$c_1 = 0.7, c_2 = 0.48, \text{ and } c_3 = 0.20.$$

For concrete filled pipes or tubing,

$$c_1 = 1.0, c_2 = 0.68, \text{ and } c_3 = 0.40.$$



10.3 COMPOSITE BEAM-COLUMNS

10.3.1 Axial Compression and Bending

Composite members subject to bending in addition to axial compression may be proportioned to satisfy the following interaction Equation:

$$f_{ca} / F_c + (f_{bx} / 0.72 F_y) A_1 + (f_{by} / 0.72 F_y) A_2 \leq 1.0 \quad \dots\dots\dots 10.15$$

Where:

- f_{ca} = Actual compressive stress due to axial force computed on steel section only.
- F_c = Allowable compressive stress computed as per Clause 10.2.3.
- A_1 = $C_{mx} / (1 - f_{ca} / F_{emx}) \geq 1.0$.
- A_2 = $C_{my} / (1 - f_{ca} / F_{emy}) \geq 1.0$.
- C_{mx}, C_{my} = Moment modification factors as per Clause 2.6.7.1.
- f_{bx}, f_{by} = Applied bending stress based on moments about the x and y axes, respectively, and neglecting composite action.
- F_y = Yield stress.
- F_{emx}, F_{emy} = Modified elastic buckling stress for buckling in x and y directions, respectively.
- F_{emx} = $3.57 E_m / \lambda_x^2$.
- F_{emy} = $3.57 E_m / \lambda_y^2$.

For cases when $f_{ca} / F_c < 0.15$, $A_1 = A_2 = 1.0$



10.3.2 Axial Tension and Bending

The interaction Equation used in the design of a beam-column may be computed on the basis of the section properties of the composite section neglecting the concrete in tension. Alternatively, composite members subjected to combined axial tension and bending shall be proportioned by neglecting the concrete.



CHAPTER 11

COLD-FORMED SECTIONS

11.1 GENERAL

This Chapter shall apply to the design of members made of cold-formed steel sheet, strip or plate and used for load carrying purposes in buildings.

11.2 CLASSIFICATION OF ELEMENTS

Cold-formed members generally have as their components flat slender thin plates with flat width-thickness ratios that do not meet the non-compact section requirements of Table 2.1. The individual plate elements are classified as stiffened, unstiffened and multiple stiffened elements depending on the stiffening arrangement provided.

11.3 MAXIMUM AND MINIMUM THICKNESS

The provisions of this Chapter apply primarily to steel sections with a thickness of not more than 8 mm although the use of thicker material is not precluded. The minimum thickness of plates for cold-formed members used for load-carrying purposes in buildings shall be taken as 1.25 mm while for sheets the minimum thickness shall be 0.5 mm.

11.4 PROPERTIES OF SECTIONS

The properties of sections shall be determined for the full cross section of the member except that the section properties for compression elements shall be based on the effective design width as specified in Table 2.3 for stiffened elements and Table 2.4 for unstiffened elements (see Clause 2.6.5.5), and the section properties for tension elements shall be based on the net area. The effective design width for compression elements with edge stiffeners or multiple stiffened elements and the stiffener requirements are detailed in Clause 11.9.

11.5 MAXIMUM ALLOWABLE FLAT WIDTH-THICKNESS RATIOS FOR COMPRESSION ELEMENTS

The following Table gives the maximum allowable flat width-thickness ratios for compression elements. The definition of flat width for the different elements is shown in Fig. 11.1.

Table (11.1) Maximum Allowable Flat Width-Thickness Ratios for Compression Elements

Description	Max. \bar{b}/t or C/t
Unstiffened compression elements (C_1 and C_2).	40
Stiffened compression element having one longitudinal edge connected to a web or flange element, the other stiffened by: (\bar{b}_1) Simple lip. Any other kind of stiffener: i) when $I_s < I_a$. ii) when $I_s \geq I_a$.	60 60 90
Stiffened compression element with both longitudinal edges connected to other stiffened elements (\bar{b}_2).	300

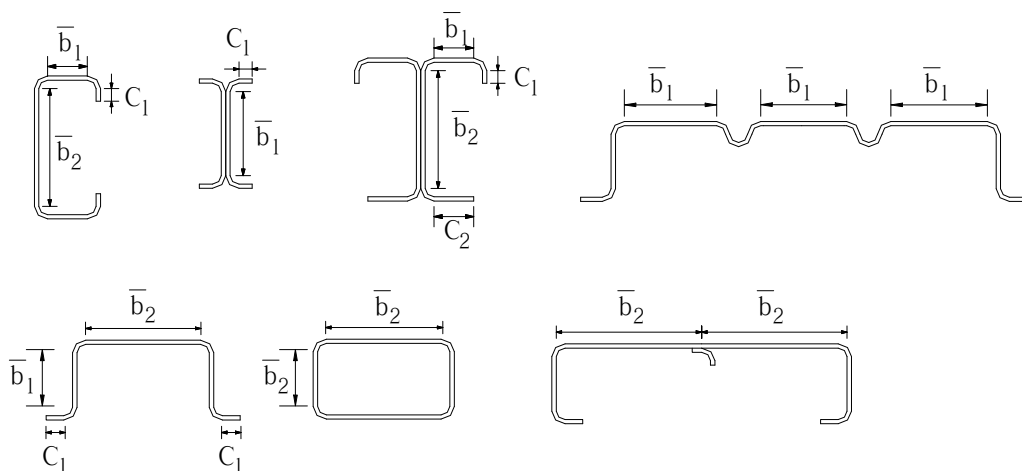


Figure (11.1) Definition of Flat Width of Compression Elements



Where I_a and I_s are the adequate and the actual moment of inertia of the stiffener as detailed in Clause 11.9.1.

11.6 MAXIMUM ALLOWABLE WEB DEPTH-THICKNESS RATIOS FOR FLEXURAL MEMBERS

Table (11.2) Maximum Allowable Web Depth-Thickness Ratios for Flexural Members

Description	Max. d_w/t_w
Unstiffened webs.	200
Webs which are provided with bearing stiffeners only.	260
Webs which are provided with bearing stiffeners and intermediate transverse stiffeners.	300

Where:

- d_w = Depth of flat portion of web measured along the plane of web.
- t_w = Web thickness.

Where a web consists of two or more sheets, the d_w/t_w ratio shall be computed for the individual sheets.

11.7 MAXIMUM ALLOWABLE DEFLECTION

The following Table gives recommended deflection limits for some structural members. Circumstances may arise where greater or lesser values would be more appropriate. Other members may also require a deflection limit to be specified, e.g., sway bracing.

The determination of the moment of inertia, I , used in computing beam deflection, shall be based on the effective section properties, for which the effective widths are computed for the compressive stresses developed from the applied bending moment. The actual compressive stresses due to applied moment shall be used to compute the normalized plate slenderness, $\bar{\lambda}_p$, rather than F_y

in Clause 2.6.5.5.

Table (11.3) Maximum Allowable Deflection

Deflection of beams due to live load without dynamic effect	
Beams carrying plaster or other brittle finish.	Span / 300
All other beams.	Span / 200
Cantilevers.	Length / 180
Purlins and side girts (rails).	To suit the characteristics of the particular cladding system.
Deflection of columns other than portal frames due to live and wind loads	
Tops of columns in single-storey buildings.	Height / 300
In each storey of a building with more than one storey.	Height of storey under consideration / 300

11.8 ALLOWABLE DESIGN STRESSES

The allowable stresses shall follow the slender section design requirements as detailed in Clause 2.6.5.5. Thus, for members under axial compression, axial tension, bending, shear, web crippling, or combined axial compression and bending, the requirements of Chapter 2 shall apply. However the allowable stresses for cylindrical tubular members shall be as given in Clause 11.13.

11.9 EFFECTIVE WIDTHS OF COMPRESSION ELEMENTS WITH AN EDGE STIFFENER OR AN INTERMEDIATE STIFFENER

11.9.1 Effective Width of Uniformly Compressed Elements with an Edge Stiffener

1- When $\bar{b}/t \leq S/3$

$I_a = 0$ (no edge stiffener required)

$b_e = \bar{b}$

11.1

$d'_s = d$; $d_s = d'_s$ for simple lip stiffener

$A'_s = d'_s t$

$A_s = A'_s$ for other stiffener shapes

$I_s = d^3 t/12$



2- When $S/3 < \bar{b}/t < S$

$$I_a = 399 \{ [(\bar{b}/t) / S] - 0.33 \}^3 t^4$$

$$C_2 = I_s/I_a \leq 1$$

$$C_1 = 2 - C_2$$

For simple lip stiffener with $140^\circ \geq \theta \geq 40^\circ$ and

$0.25 < D/\bar{b} \leq 0.8$ and θ is as shown in Fig. 11.3, the effective width for the flange is determined as:

$b_e = \rho \bar{b}$ according to Table 2.3 with the following k_σ

$$k_\sigma = [4.82 - 5(D/\bar{b})] (I_s/I_a)^{1/2} + 0.43 \leq 5.25 - 5(D/\bar{b})$$

11.2

For simple lip stiffener with $140^\circ \geq \theta \geq 40^\circ$ and

$0.25 \geq D/\bar{b}$, the value of k_σ becomes:

$$k_\sigma = 3.57 (I_s/I_a)^{1/2} + 0.43 \leq 4$$

The effective width of the stiffener is determined from

Table 2.4 as: $d'_s = \rho d$ with the value of $k_\sigma = 0.43$

$$d_s = C_2 d'_s = (I_s/I_a) d'_s$$

$$A'_s = d'_s t; A_s = (I_s/I_a) A'_s$$

3- When $\bar{b}/t \geq S$

$$I_a = \{ [115 (\bar{b}/t) / S] + 5 \} t^4$$

$$C_2 = I_s/I_a \leq 1$$

$$C_1 = 2 - C_2$$

For simple lip stiffener with $140^\circ \geq \theta \geq 40^\circ$ and

$0.25 < D/\bar{b} \leq 0.8$ and θ is as shown in Fig. 11.3, the effective width for the flange is determined as:

$b_e = \rho \bar{b}$ according to Table 2.3 with the following k_σ

$$k_\sigma = [4.82 - 5(D/\bar{b})] (I_s/I_a)^{1/3} + 0.43 \leq 5.25 - 5(D/\bar{b})$$

11.3

For simple lip stiffener with $140^\circ \geq \theta \geq 40^\circ$ and

$0.25 \geq D/\bar{b}$, the value of k_σ becomes:

$$k_\sigma = 3.57 (I_s/I_a)^{1/3} + 0.43 \leq 4$$

The effective width of the stiffener is determined from

Table 2.4 as: $d'_s = \rho d$ with the value of $k_\sigma = 0.43$

$$d_s = C_2 d'_s = (I_s/I_a) d'_s$$

$$A'_s = d'_s t; A_s = (I_s/I_a) A'_s$$

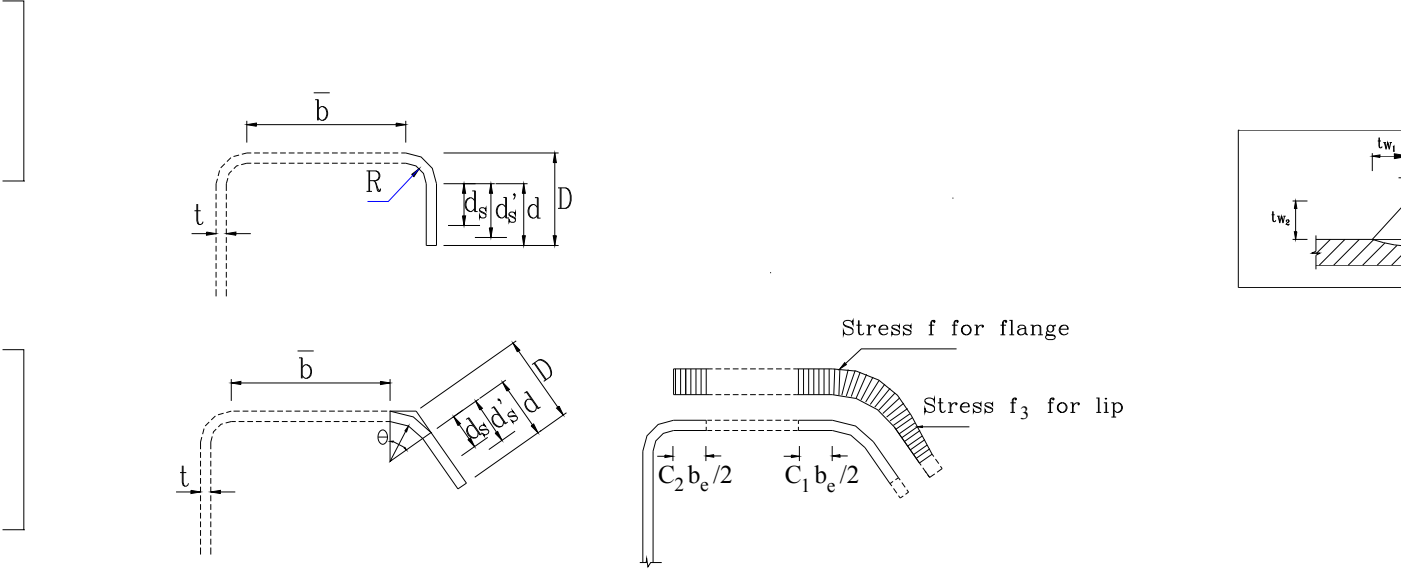


Figure (11.3) Elements with Edge Stiffener

In the previous equations:

- S** = $1.28 \sqrt{E/F_y}$ **11.4**
- F_y** = Yield stress.
- K_σ** = Plate buckling factor.
- B₀** = Dimension defined in Fig. 11.4.
- D, d,**
b = Dimensions defined in Fig. 11.3.
- d_s** = Reduced effective width of the stiffener, **d_s** shall be used in computing the overall effective section properties.
- D'_s** = Effective width of the stiffener according to Table 2.4.
- C₁, C₂** = Coefficients defined according to Fig. 11.3 to calculate the effective width instead of Table 2.3.
- A_s** = Reduced area of the stiffener. It shall be used in computing the overall effective section properties. The centroid of the stiffener is to be considered located at the centroid of the full area of the stiffener.
- I_a** = Adequate moment of inertia of the stiffener, so that each



component element can behave as a stiffened element.

$I_s, A'_s =$ Moment of inertia of the full section of the stiffener about its own centroidal axis parallel to the element to be stiffened, and the effective area of the stiffener, respectively. For edge stiffeners, the round corner between the stiffener and the element to be stiffened shall not be considered as part of the stiffener.

For the stiffener shown in Fig. 11.3.

$$I_s = (d^3 t \sin^2 \theta) / 12 \quad \dots \dots \dots 11.5$$

$$A'_s = d'_s t \quad \dots \dots \dots 11.6$$

11.9.2 Effective Width of Uniformly Compressed Elements with One Intermediate Stiffener

1- When $b_0/t \leq S$

$I_a = 0$ (no intermediate stiffener required)

$$b_e = \bar{b}$$

$$11.7$$

$A_s = A'_s =$ area of intermediate stiffener, Fig. 11.4b.

2- When $S < b_0/t < 3S$

$$I_a = \{ [50 (b_0/t) / S] - 50 \} t^4$$

The effective width for the flange is determined as:

$b_e = \rho \bar{b}$ according to Table 2.3 with the following k_σ

$$k_\sigma = 3 (I_s / I_a)^{1/2} + 1 \leq 4$$

The reduced intermediate stiffener area is calculated from: 11.8

$$A_s = A'_s (I_s / I_a) \leq A'_s$$

Where I_s is the moment of inertia of the intermediate stiffener about the x-x axis, as shown in Fig. 11.4b.

3- When $b_0/t \geq 3S$

$$I_a = \{ [128 (b_0/t) / S] - 285 \} t^4$$

The effective width for the flange is determined as:

$b_e = \rho \bar{b}$ according to Table 2.3 with the following k_σ

$$11.9$$

$$k_\sigma = 3 (I_s / I_a)^{1/3} + 1 \leq 4$$

$$A_s = A'_s (I_s / I_a) \leq A'_s$$

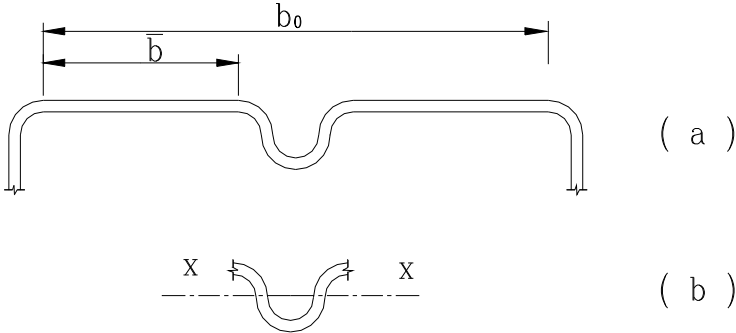


Figure (11.4) Elements with Intermediate Stiffener

11.9.3 Effective Width of Edge Stiffened Elements with Intermediate Stiffeners or Stiffened Elements with More than One Intermediate Stiffener

11.9.3.1 Minimum Intermediate Stiffener Inertia

Intermediate stiffeners of an edge stiffened element or the stiffeners of a stiffened element with more than one stiffener as shown in Figure 11.5 shall have a minimum moment of inertia (I_{min} in cm^4) given by:

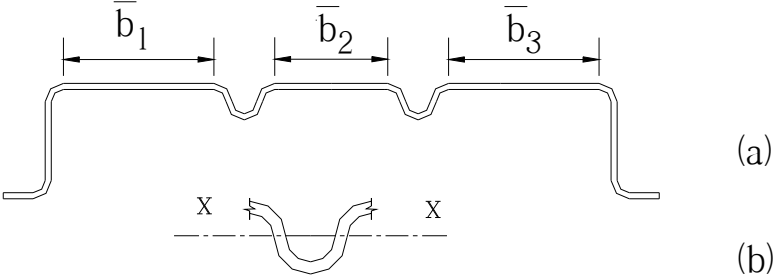


Figure (11.5) Sections with Multiple-Stiffened Compression Elements

$$I_{min} = 3.66t^4 \sqrt{(\bar{b}/t)^2 - 280/F_y} \geq 18.4t^4 \tag{11.10}$$

.....



Where:

- I_{\min} = Minimum moment of inertia of the full stiffener about its own centroidal axis parallel to the element to be stiffened.
 \bar{b}/t = Flat-width to thickness ratio of the larger stiffened sub element.

11.9.3.2 Effective Design Width of Sub Elements

For multiple-stiffened compression elements, the effective widths of sub elements are determined by the following Equations:

$$1- \text{ If } \bar{b}/t \leq 60 \quad \mathbf{b_{em} = b_e} \quad \text{.....} \quad \mathbf{11.11}$$

$$2- \text{ If } \bar{b}/t > 60 \quad \mathbf{b_{em} = b_e - 0.10 t [\bar{b}/t - 60]} \quad \text{.....} \quad \mathbf{11.12}$$

Where:

- \bar{b}/t = Flat-width to thickness ratio of element or sub element.
 b_{em} = Effective design width of element or sub element to be used in design computations.
 b_e = Effective design width determined for single-stiffened compression element (cm) with \bar{b} as shown in Fig. 11.5a (refer to Table 2.3).

11.9.3.3 Effective Stiffener Area

In computing the effective structural properties for a member having intermediate stiffeners and when the \bar{b}/t ratio of the sub element exceeds **60**, the effective stiffener area (A_{eff}) (edge stiffener or intermediate stiffeners) shall be computed as follows:

$$1- \text{ If } \bar{b}/t \leq 60 \quad \mathbf{A_{eff} = A_{st}} \quad \text{.....} \quad \mathbf{11.13}$$

$$2- \text{ If } 60 < \bar{b}/t < 90 \quad \mathbf{A_{eff} = \alpha \cdot A_{st}} \quad \text{.....} \quad \mathbf{11.14}$$

$$\text{Where: } \alpha = [3 - 2 b_{em} / \bar{b}] - 1/30 [1 - b_{em} / \bar{b}] [\bar{b}/t]$$

$$3- \text{ If } \bar{b}/t \geq 90 \quad \mathbf{A_{eff} = [b_{em} / \bar{b}] \cdot A_{st}} \quad \mathbf{11.15}$$

.....
where A_{st} is the area of the relevant stiffener, Fig. 11.5.b.

In the above Equation, A_{eff} and A_{st} refer to the area of the stiffener section, exclusive of any portion of adjacent element. In the calculation of sectional properties, the centroid of the full section of the stiffener and the moment of inertia of the stiffener about its own centroidal axis shall be that of the full section of the stiffener.

11.10 BEAMS WITH UNUSUALLY WIDE FLANGES

For beams with unusually wide flanges, special consideration shall be given to the effects of shear lag and flange curling, even if the beam flanges, such as tension flanges, do not buckle.

11.10.1 Shear Lag Effect

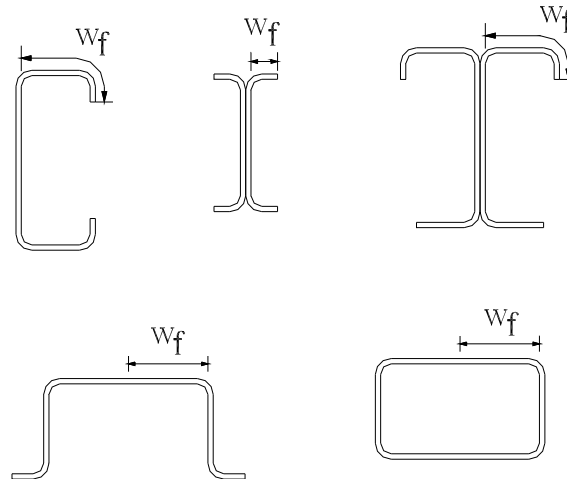


Figure (11.6) Definition of (w_f) of Compression Elements

The ratio of effective flange width to the actual width as per Clause 2.6.5.5 shall not exceed the values specified in Table 11.4. The effective span length of the beam, L , is the full span for simple beams, the distance between inflection points for continuous beams, or twice the length of cantilever beams. The symbol, w_f , is defined as shown in Fig. 11.6.



Table (11.4) Maximum Ratio of Effective Flange Width to Actual Width

L/w_f	Effective Flange Width / Actual Flange Width	L/w_f	Effective Flange Width / Actual Flange Width
30	1.00	14	0.82
25	0.96	12	0.78
20	0.91	10	0.73
18	0.89	8	0.67
16	0.86	6	0.55

11.10.2 Flange Curling

The width of the flange projection beyond the web, w_f , for C-beams or similar, or half the distance between webs of multiple web sections (whether the flange is in tension or compression, stiffened or unstiffened) shall not exceed the following to avoid flange curling:

$$w_f = 0.37 \{t d E / f_{av}\}^{1/2} \dots\dots\dots 11.16$$

Where:

t = Flange thickness.

d = Overall depth of the section.

f_{av} = Average bending stresses in the flange in full, unreduced flange width.

11.11 COMPRESSION MEMBERS

11.11.1 Slenderness Ratios

The maximum slenderness ratios of compression members shall be according to Clause 4.2.1.

11.11.2 Effective Buckling Length ($K\ell$)

The effective buckling length ($K\ell$) of a compression member may be taken from Table 4.4, or obtained from an elastic critical buckling analysis.



11.12 TENSION MEMBERS

11.12.1 Slenderness Ratios

The maximum slenderness ratios of tension members shall be according to Clause 4.2.2.

11.12.2 Effective Area

The properties of the cross section shall be computed from the effective net sectional area, in case of using bolts for connections. Effective net area shall be according to Clause 2.7.1.

11.13 CYLINDRICAL TUBULAR MEMBERS

The thickness of the cylindrical tubular members shall be chosen such that the ratio of outside diameter to wall thickness, D/t , shall not exceed $735 / F_y$.

11.13.1 Slenderness Ratios

The maximum slenderness ratios of cylindrical tubular members shall be according to Clause 4.2.

11.13.2 Effective Buckling Length ($K\ell$)

The effective buckling length ($K\ell$) of a cylindrical tubular member may be taken from Table 4.4, or obtained from an elastic critical buckling analysis.

11.13.3 Allowable Stress for Members under Bending

The allowable bending stress (F_b) in a cylindrical tubular member shall be calculated as follows:

$$\text{For } D/t \leq 140/F_y \\ F_b = 0.64 F_y \dots\dots\dots 11.17$$

$$\text{For } 140 / F_y < D/t \leq 580 / F_y \\ F_b = \left[0.45 + \left(\frac{25/F_y}{D/t} \right) \right] F_y \dots\dots\dots$$



11.18

For $580 / F_y < D/t \leq 735 / F_y$

$$F_b = \left[\frac{270}{D/t} \right] \dots\dots\dots 11.19$$

Where F_y is in t/cm^2

The elastic section modulus to be used in the calculations shall be for the full, unreduced cross section.

11.13.4 Allowable Stress for Members under Compression

The following Equations shall be used to define the allowable compressive stress, F_r , for circular tubes:

$$\text{For } \lambda_c \leq 1.5 \quad F_r = \left(0.658^{\lambda_c^2} \right) \cdot \frac{F_y}{2} \dots\dots\dots 11.20$$

$$\text{For } \lambda_c > 1.5 \quad F_r = \left[\frac{0.437}{\lambda_c^2} \right] \cdot F_y \dots\dots\dots 11.21$$

Where:

$$\lambda_c = \sqrt{F_y / F_e} , \text{ and}$$

$$F_e = \text{The flexural buckling stress} = \frac{\pi^2 E}{(Kl/r)^2}$$

The effective area to be used for calculating the axial strength, A_e , shall be determined as follows:

$$A_e = \left[1 - \left(1 - \frac{F_y}{2F_e} \right) (1 - A_0/A) \right] \cdot A \dots\dots\dots 11.22$$

Where A = Area of the full, unreduced cross section.

$$A_0 = \left[\frac{75}{(D/t)F_y} + 0.667 \right] \cdot A \leq A$$



11.13.5 Allowable Stresses for Members under Combined Bending and Compression

Combined bending and compression shall satisfy the requirements of Clause 2.6.7.1.

11.14 SPLICES

Splices in compression or tension members shall be designed on the actual forces in the members.

11.15 CONNECTIONS

Connections of members at an intersection shall be designed on the actual forces in the members.

11.15.1 WELDED CONNECTIONS

The following design criteria govern Arc welded connections used for cold-formed steel structural members in which the thickness of the thinnest connected part is 4 mm or less. For welded connections where the thickness of the thinnest connected part is greater than 4 mm, the provisions of Chapter 5 shall apply.

Resistance welds, which are produced by the heat obtained from resistance to an electric current through the work parts held together under pressure by electrodes, are possible.

11.15.1.1 Arc Welds

Several types of arc welds are generally used in cold-formed steel construction such as:

1- Groove welds, 2- Arc spot welds, 3- Arc seam welds, 4- Fillet welds, and 5- Flare groove welds.

p
Figure (11.7) Groove Welds in Butt Joints

11.15.1.1.1 Groove Welds in Butt Joints



In the design of groove welds in butt joints, the allowable stress in tension or compression is **0.7** times for tension or the same for compression, as that prescribed for the lower strength base steel in connection, provided that an effective throat is equal to or greater than the thickness of the material, and that the strength of the weld metal is equal to or greater than the strength of the base steel.

11.15.1.1.2 Arc Spot Welds

- 1-** Arc spot welds should not be used to weld steel sheets where the thinnest connected part is over **4** mm thick, nor through a combination of steel sheets having a total thickness of over **4** mm.
- 2-** Weld washers should be used when the thickness of the sheet is less than **0.7** mm. Weld washers should have a thickness of between **1.3** mm and **2** mm with a minimum prepunched hole of **10** mm diameter.
- 3-** The minimum allowable effective diameter d_e is **10** mm.
- 4-** The distance measured along the line of application of force from the centerline of a weld to the nearest edge of an adjacent weld or to the end of the connected part toward which the force is directed should not be less than the value of e_{min} as given by:



$$e_{\min} = \frac{P}{0.4 F_u t} \dots\dots\dots 11.23$$

Where:

- P** = Force transmitted by an arc spot weld.
- t** = Thickness of thinnest connected sheet.
- F_u** = Specified minimum tensile strength of steel (base metal).

5- The distance from the centerline of any weld to the end or boundary of the connected member should not be less than **1.5d**. In no case should the clear distance between welds and end of member be less than **d**.

6- The allowable load on each arc spot weld between sheet or sheets and supporting member shall not exceed the smaller value of the loads computed by the following Equations:

i- Allowable load based on shear capacity of weld

$$P_a = 0.3 F_u \pi d_e^2 / 4 \dots\dots\dots 11.24$$

ii- Allowable load based on strength of connected sheets

a- For $36 / \sqrt{F_u} \geq d_a / t$

$$P_a = 0.8 F_u d_a t \dots\dots\dots 11.25$$

b- For $36 / \sqrt{F_u} < d_a / t < 64 / \sqrt{F_u}$

$$P_a = 0.105 F_u \left(1 + \frac{240}{d_a / t \sqrt{F_u}} \right) d_a t \dots\dots\dots 11.26$$

c- For $d_a / t \geq 64 / \sqrt{F_u}$

$$P_a = 0.5 F_u d_a t \dots\dots\dots 11.27$$

Where:

- d** = Visible diameter of outer surface of arc spot weld.
d_a = Average diameter of arc spot weld at mid-thickness of **t** (as shown in Figure 11.8) = **d - t** for single sheet, and = **d - 2t** for multiple sheets (not more than four lapped sheets over a supporting member).
d_e = Effective diameter of fused area = **0.7 d - 1.5 t ≤ 0.55 d**.
t = Total combined base steel thickness (exclusive of coating) of sheets involved in shear transfer.
F_y = Specified minimum yield stress of steel.
F_u = Specified minimum tensile strength of steel.

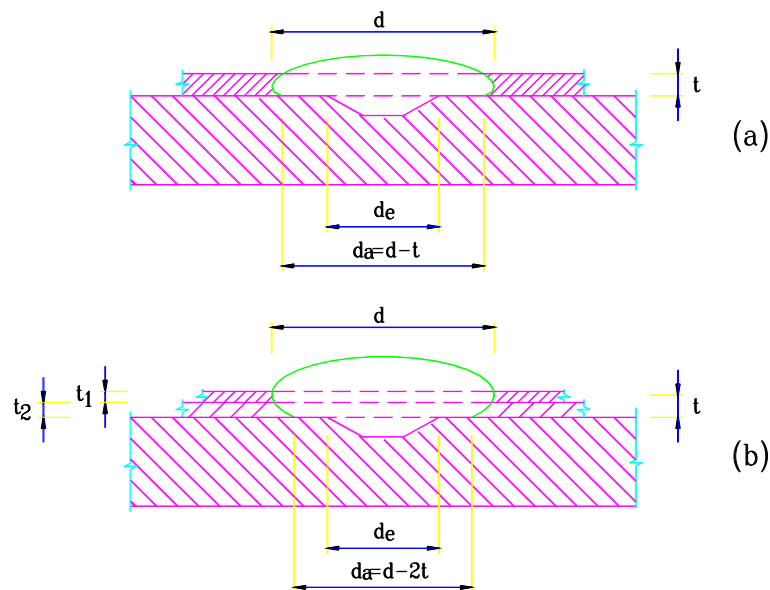


Figure (11.8) Definition of d , d_a and d_e in Arc Spot Weld
a- Single Sheet b- Double Sheet

11.15.1.1.3 Arc Seam Welds

For arc seam welds, the allowable load on each arc seam weld shall be taken as the smaller of the values computed by the following Equations:

- i- Allowable load based on shear capacity of weld

$$P_a = 0.3 F_u (\pi d_e^2 / 4 + L d_e) \dots\dots\dots 11.28$$
- ii- Allowable load based on strength of connected sheets

$$P_a = 0.4 F_u (0.625 L + 2.4 d_a) t \dots\dots\dots 11.29$$

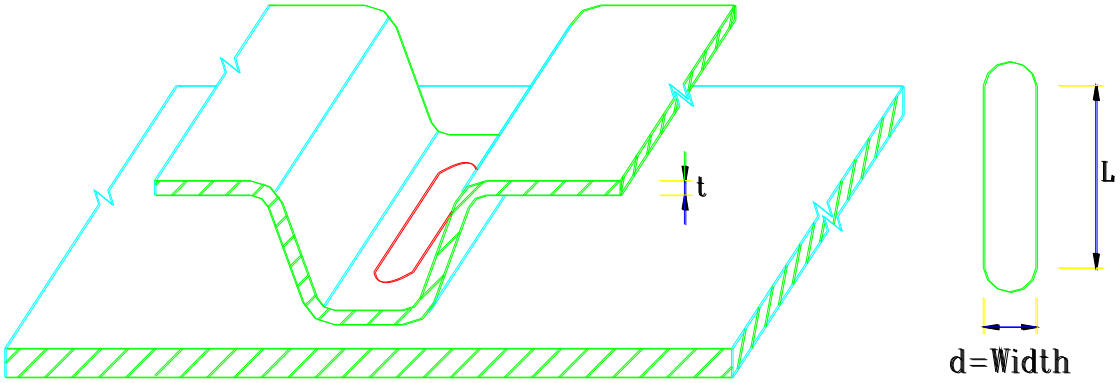


Figure (11.9) Arc Seam Welds

Where:
d = Width of arc seam weld.
L = Length of seam weld not including circular ends, ($L < 3d$).
d_e, **d_a**, and **F_u** are as defined in arc spot welds .

The requirements for minimum edge distance are the same as those for arc spot welds.

11.15.1.1.4 Fillet Welds

The allowable load for a fillet weld in lap and T-joints shall not exceed the values computed by Equation 11.30 for the shear strength of the fillet weld and by Equations 11.31,11.32, and 11.33 for the strength of the connected sheets as follows:

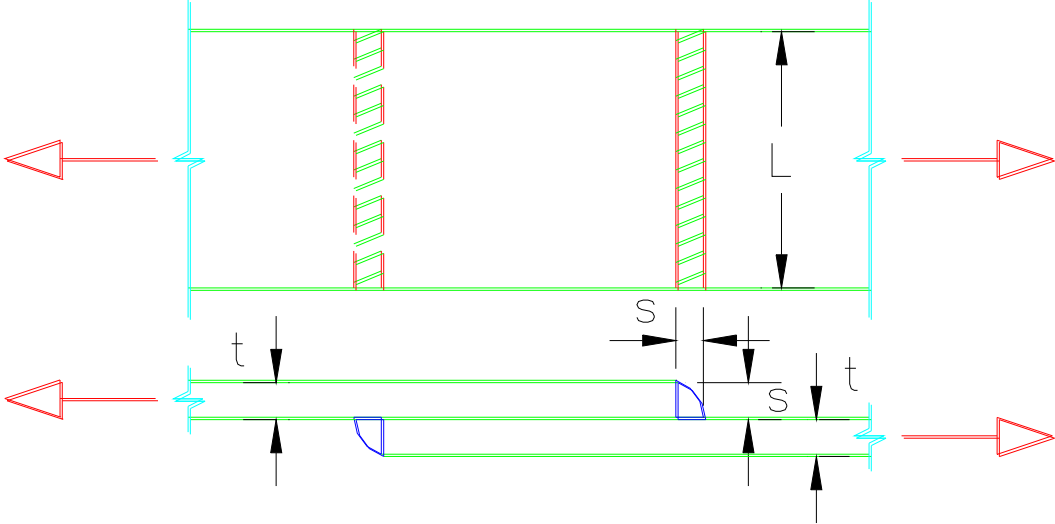


Figure (11.10) Fillet Welds

i- Allowable load based on shear capacity of weld

$$P_a = 0.2 F_u (s L) \dots\dots\dots 11.30$$

ii- Allowable load based on strength of connected sheets

a- Longitudinal loading

when $L/t < 25$ $P_a = 0.4 F_u (1 - 0.01 L/t) (t L) \dots$ **11.31**

when $L/t \geq 25$ $P_a = 0.3 F_u (t L) \dots\dots\dots$ **11.32**

b- Transverse loading

$$P_a = 0.4 F_u (t L) \dots\dots\dots 11.33$$

Where:

- L** = Length of fillet weld.
- s = s₁ or s₂** = Leg sizes of fillet welds, use whichever is smaller.

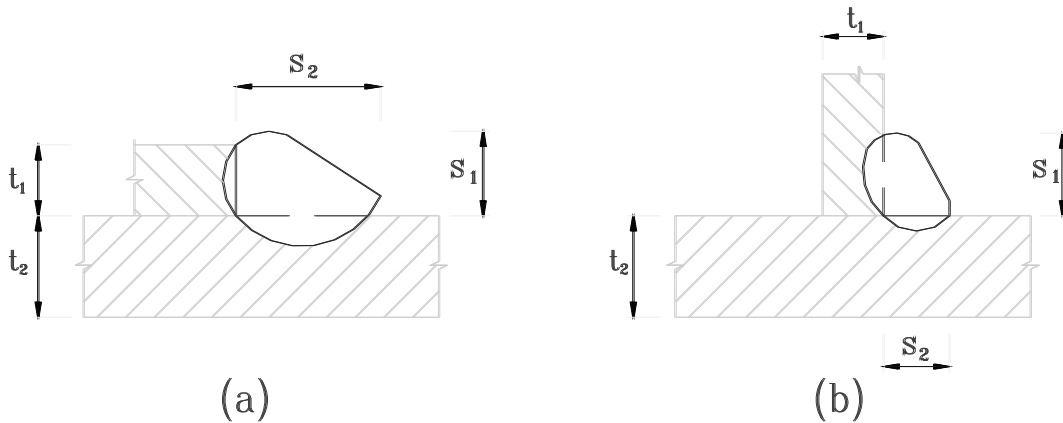


Figure (11.11) Leg Sizes of Fillet Welds
a- Lap Joint b- T-Joint

11.15.1.1.5 Flare Groove Welds

The allowable load for each flare groove weld shall be determined

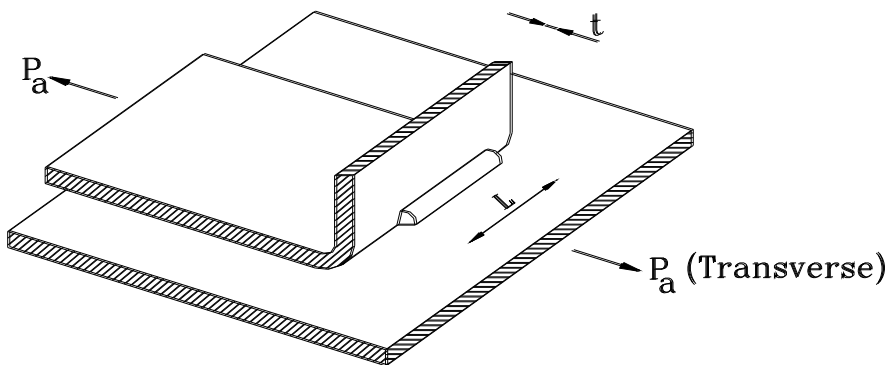


Figure (11.12a) Transverse Flare Bevel Weld

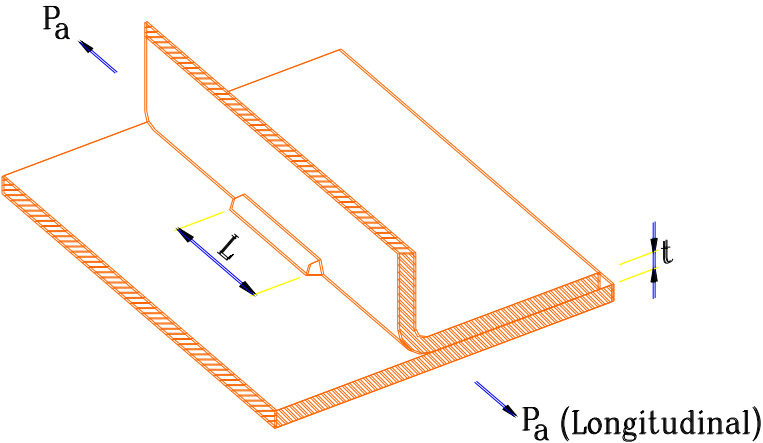


Figure (11.12b) Longitudinal Flare Bevel Weld

i- Allowable load based on shear capacity of weld

$$P_a = 0.3 F_u L s \dots\dots\dots 11.34$$

ii- Allowable load based on strength of connected sheets

a- Transverse loading

$$P_a = 0.33 F_u (t L) \dots\dots\dots 11.35$$

b- Longitudinal loading

If $t \leq t_w < 2t$ or if the lip height is less than the weld length,

$$P_a = 0.3 F_u (t L) \dots\dots\dots 11.36$$

If $t_w \geq 2t$ and the lip height is equal to or greater than L ,

$$P_a = 0.6 F_u (t L) \dots\dots\dots 11.37$$

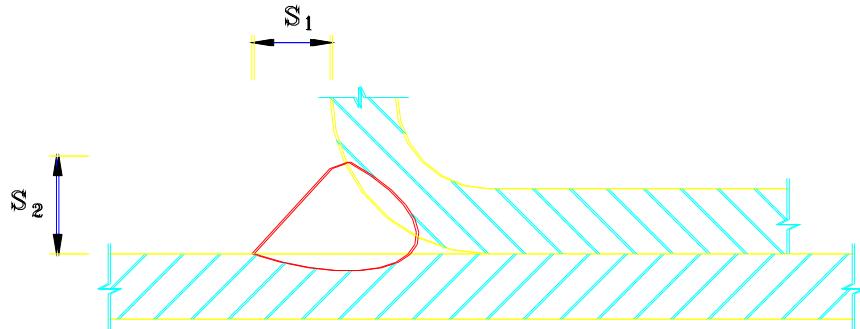


Figure (11.13) Effective Size Dimension t_w for Flare Groove Welds – Smaller of s_1 and s_2

The definition of t_w in such case is as shown in Figure 11.13.

11.15.1.2 Resistance Welds

The shear strength of spot resistance welding shall be determined as given in the following Table:

Thickness of Thinnest Outside Sheet	Shear Strength per Spot	Thickness of Thinnest Outside Sheet	Shear Strength per Spot	Thickness of Thinnest Outside Sheet	Shear Strength per Spot
(mm)	(kg)	(mm)	(kg)	(mm)	(kg)
0.50	77	1.75	450	3.10	1160
0.75	160	2.00	530	4.80	1625
1.00	225	2.25	640	6.40	2400
1.25	265	2.50	800		
1.50	360	2.75	975		

11.15.2 BOLTED CONNECTIONS

The following design criteria govern bolted connections used for cold-formed steel structural members in which the thickness of the



thinnest connected part is **4 mm** or less. For bolted connections where the thickness of the thinnest connected part is greater than **4 mm**, the provisions of Chapter 6 shall apply.

11.15.2.1 Minimum Spacing and Edge Distance in Line of Stress

The distance (**e**) measured in the line of force from the center of a standard hole to the nearest edge of an adjacent hole or to the end of the connected part toward which the force is directed should not be less than the value of **e_{min}** determined by:

$$e_{min} = \frac{\alpha d}{0.4} \dots\dots\dots 11.38$$

Where:

- α** = Bearing stress coefficient as given in Table 6.2.
- d** = Bolt diameter.

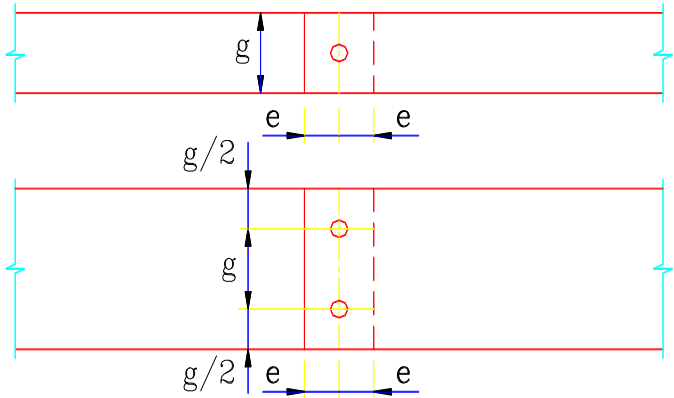


Figure (11.14) Spacing and Edge Distance of Bolts

The nominal clearance in standard holes shall be as previously outlined in clause 6.2.2 as follows:

- 1 mm for M12 and M14 bolts
- 2 mm for M16 up to M24 bolts
- 3 mm for M27 and larger



In addition to the previous requirement, the following requirements concerning minimum spacing and edge distance in the line of stress shall also be considered:

1. The minimum distance between centers of bolt holes shall not be less than **3d**.
2. The distance from the center of any standard hole to the end or other boundary of the connecting member shall not be less than **1.5d**.
3. The clear distance between edges of two adjacent holes shall not be less than **2d**.
4. The distance between the edge of the hole and the end of the member shall not be less than **d**.
5. For slotted holes, the distance between edges of two adjacent holes and the distance measured from the edge of the hole to the end or other boundary of the connecting member in the line of stress shall not be less than the value of $(e_{\min} - 0.5d_h)$, in which e_{\min} is the required distance computed from the above Equation and d_h is the diameter of a standard hole.

11.15.2.2 Allowable Tensile Stress on Net Section of Connected Parts

The allowable tensile stress on the net section of a bolted connection shall be the smaller of F_t or F_{tt} , which is computed by using the following Equations according to the conditions therein:

i- With washers under both bolt head and nut

$$F_{tt} = (1.0 - 0.9 r + 3 r d / g) 0.58F_y \leq 0.58F_y \quad \dots\dots \quad 11.39$$

ii- Without washers under both bolt head and nut, or with only one washer

$$0 - r + 2.5 r d / g) 0.58F_y \leq 0.58F_y \quad \dots\dots \quad 11.40$$



Where:

- r** = Force transmitted by bolt or bolts at the section considered, divided by tension force in member at that section. If **r** is less than **0.2** it may be taken as zero.
- g** = Spacing of bolts perpendicular to the line of stress. In the case of a single bolt, **g** = gross width of sheet.
- F_{tt}** = Allowable tensile stress on the net section.

11.15.2.3 Allowable Bearing Stress between Bolts and Connected Parts

The allowable bearing stress **F_b** between bolts and the parts connected to them is taken as detailed in Clause 6.4.2.

11.15.2.4 Allowable Shear Stress on Bolts

The allowable shear stress **q_b** on the gross sectional area of bolts is taken as detailed in Cause 6.4.1.

11.15.2.5 Allowable Tensile Stress on Bolts

The allowable tensile stress **F_{tb}** on the net sectional area of bolts is taken as detailed in Clause 6.4.3.

11.15.3 SCREWS

The following requirements shall apply to self-tapping screws with **2 mm ≤ d ≤ 6 mm**. The screws shall be thread-forming or thread-cutting, with or without a self-drilling point.

Screws shall be installed and tightened in accordance with the manufacturer's recommendations.

The nominal tension strength on the net section of each member joined by a screw connection shall not exceed the member nominal tensile strength from Chapter 2 or the connection nominal tensile strength from this section.



11.15.3.1 Minimum Spacing

The distance between the centers of fasteners shall not be less than **3d**.

11.15.3.2 Minimum Edge and End Distance

The distance from the center of a fastener to the edge of any part shall not be less than 3d. If the connection is subjected to shear force in one direction only, the minimum edge distance shall be 1.5d in the direction perpendicular to the force.

11.15.3.3 Shear

11.15.3.3.1 Connection Shear

The allowable shear strength per screw, P_{ns} , shall be determined as follows:

For $t_2/t_1 \leq 1.0$, P_{ns} shall be taken as the smallest of:

$$\left. \begin{aligned}
 P_{ns} &= 1.4 (t_2^3 d)^{1/2} F_{u2} \\
 P_{ns} &= 0.9 t_1 d F_{u1} \\
 &\dots\dots\dots \\
 P_{ns} &= 0.9 t_2 d F_{u2}
 \end{aligned} \right\} \dots\dots\dots \mathbf{11.41}$$

For $t_2/t_1 \geq 2.5$, P_{ns} shall be taken as the smallest of:

$$\left. \begin{aligned}
 P_{ns} &= 0.9 t_1 d F_{u1} \\
 P_{ns} &= 0.9 t_2 d F_{u2}
 \end{aligned} \right\} \dots\dots\dots \mathbf{11.42}$$

For $1.0 < t_2/t_1 < 2.5$, P_{ns} shall be determined by linear interpolation between the above two cases.

Where:

d = Screw diameter (cm).

P_{ns} = Allowable shear strength per screw (ton).



- t_1 = Thickness of member in contact with the screw head (cm).
- t_2 = Thickness of member not in contact with the screw head (cm).
- F_{u1} = Tensile strength of member in contact with the screw head (t/cm^2).
- F_{u2} = Tensile strength of member not in contact with the screw head (t/cm^2).

11.15.3.3.2 Shear in Screws

The allowable shear strength of the screw shall be provided by the screw manufacturer.

11.15.3.4 Tension

For screws which carry tension, the head of the screw or washer, if a washer is provided, shall have a diameter d_w not less than 8 mm. Washers shall be at least 1.2 mm thick.

11.15.3.4.1 Pull-Out

The allowable pull-out strength, P_{not} , shall be calculated as follows:

$$P_{not} = 0.28 t_c d F_{u2} \dots\dots\dots 11.43$$

Where t_c is the lesser of the depth of penetration and the thickness, t_2 .

11.15.3.4.2 Pull-Over

The allowable pull-over strength, P_{nov} , shall be calculated as follows:

$$P_{nov} = 0.5 t_1 d_w F_{u1} \dots\dots\dots 11.44$$

Where d_w is the larger of the screw head diameter or the washer diameter, and shall be taken not larger than **12 mm**.



11.15.3.4.3 Tension in Screws

The allowable tension strength, P_{nt} , per screw shall be determined by approved tests. The allowable tension strength of the screw shall not be less than **1.25** times the lesser of P_{not} and P_{nov} .

11.15.4 BUILT-UP SECTIONS

11.15.4.1 I-Sections Composed of Two Channels

The maximum longitudinal spacing of connectors shall be limited to the following values:

a- For compression members

$$s_{max} = L r_{cy} / (2 r_l) \dots\dots\dots 11.45$$

Where:

- s_{max} = Maximum permissible longitudinal spacing of connectors.
- L = Unbraced length of compression member.
- r_l = Radius of gyration of the I-section about the axis perpendicular to the direction in which buckling would occur for the given conditions of end support and intermediate bracing, if any.
- r_{cy} = Radius of gyration of one channel about the centroidal axis parallel to web.

b- For beams

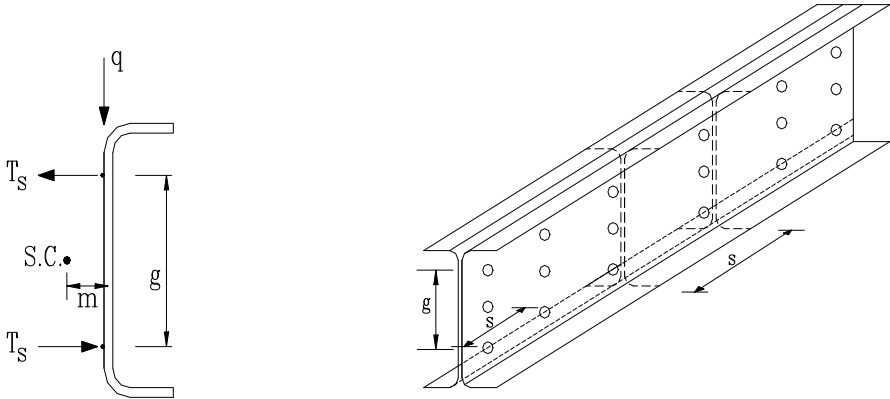


Figure (11.15) Forces on a Channel of a Built-Up Member

$$s_{max} = L / 6 \dots\dots\dots 11.46$$

$$s_{max} \leq \frac{2gT_s}{m.q} \dots\dots\dots 11.47$$

Where:

- L** = Span of beam.
- g** = Vertical distance between the two rows of connectors nearest to the top and bottom flanges.
- T_s** = Tensile strength of connectors.
- q** = Intensity of load.
- m** = Distance between shear center of one channel and mid plane of its web.

For simple channels without stiffening lips at the outer edges:



$$m = \frac{w_f^2}{2w_f + d/3} \dots\dots\dots 11.48$$

For C-shaped channels with stiffening lips at the outer edges:

$$m = \frac{w_f d t}{4 I_x} \left[w_f d + 2D \left(d - \frac{4D^2}{3d} \right) \right] \dots\dots\dots 11.49$$

Where:

- w_f** = Projection of flanges from inside face of web.
- d** = Depth of channels.
- t** = Thickness of channel section.
- D** = Overall depth of stiffening lip.
- I_x** = Moment of inertia of one channel about its centroidal axis normal to web.

If the length of bearing of a concentrated load or reaction is smaller than the spacing of the connectors, the required strength of connectors closest to the load or reaction **P** is:

$$T_s = P \cdot m / (2 \cdot g) \dots\dots\dots 11.50$$

11.15.4.2 Spacing of Connectors in Compression Elements

The spacing **s**, in the line of stress of welds, bolts or rivets connecting the compression cover plate or sheet to another element should not exceed:

1- That which is required to transmit the shear between the connected parts on the basis of the design strength per connector, nor

2- $s = 50 t / \sqrt{f}$, where **s** is the spacing, **t** is the thickness of the cover plate or sheet, and **f** is the design stress in the cover plate or sheet, nor

3- Three times the flat width \bar{b} of the narrowest unstiffened compression element related to the connection.

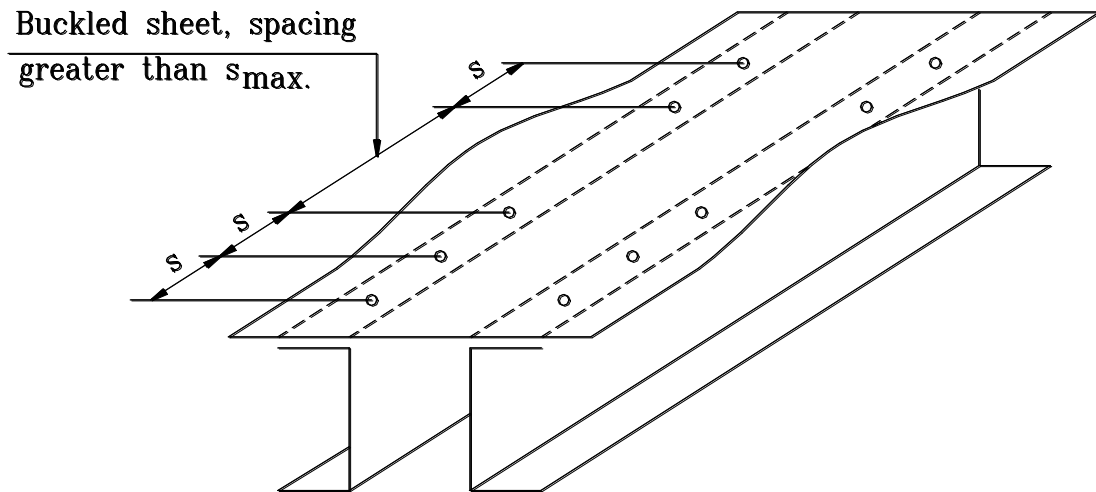


Figure (11.16) Spacing of Connectors in Compression Elements



CHAPTER 12

DIMENSIONAL TOLERANCES

12.1 GENERAL

Steel structures consist of prefabricated elements which are assembled together in the erection stage. In order to ensure the real safety of the structure in comparison to the theoretical assumption concerning the geometry of the load application, the dimensional tolerances specified herein shall be observed

12.2 TYPES OF TOLERANCES

12.2.1 Normal Tolerances

Normal tolerances are the basic limits for dimensional deviations necessary:

- To satisfy the design assumptions for statically loaded structures.
- To define acceptable tolerances for building structures in the absence of any other requirements.

12.2.2 Special Tolerances

Special tolerances are more stringent tolerances necessary to satisfy the design assumptions:

- For structures other than normal building structures.
- For structures in which fatigue predominates.

12.2.3 Particular Tolerances

Particular tolerances are more stringent tolerances necessary to satisfy functional requirements of particular structures or structural components, related to:

- Attachment of other structural or non-structural components.
- Shafts for lifts (elevators).
- Tracks for overhead cranes.
- Other criteria such as clearances.



- Alignment of external face of building.

12.3 APPLICATION OF TOLERANCES

1. All tolerance values specified in the following shall be treated as normal tolerances.
2. Normal tolerances apply to conventional single-storey and multi-storey steel framed structures of residential, administrative, commercial and industrial buildings except where special or particular tolerances are specified.
3. Any special or particular tolerances required shall be detailed in the Project Specification.
4. Any special or particular tolerances required shall also be indicated on the relevant drawings.

12.4 NORMAL ERECTION TOLERANCES

1. The following normal tolerance limits relate to the steel structure in the unloaded state, i.e., structure loaded only by its own weight, see the following Tables and figures.
2. Each criterion given in the Tables shall be considered as a separate requirement, to be satisfied independently of any other tolerances criteria.
3. The fabrication and erection tolerances specified in Clauses 12.5 to 12.7 apply to the following reference points:
 - For a column, the actual center point of the column at each floor level and at the base, excluding any base plates.
 - For a beam, the actual center point of the top surface at each end of the beam excluding any endplate.
4. All elements should be checked after fabrication and before erection for the allowable tolerances according to Clause 12.5.

12.5 PERMISSIBLE DEVIATIONS OF FABRICATED ELEMENTS

Deviation		a_{max}	Fig.
Deflection of column between points which will be laterally restrained on completion of erection.	f_{h1}	$\pm 0.001 h_{11}$ generally. $\pm 0.002 h_{11}$ for members with hollow cross-section. h_{11} is the height between points which will be laterally restrained.	12.1
Deflection of column between floor slabs.	f_h	$\pm 0.001 h_1$ generally. $\pm 0.002 h_1$ for members with hollow cross-section. h_1 is the height between floor slabs.	12.1
Lateral deflection of compression flange of girder, relative to the weak axis, between points which will be laterally restrained on completion of erection.	f_{11}	$\pm 0.001 l_{b1}$ generally. $\pm 0.002 l_{b1}$ for members with hollow cross-section. l_{b1} is the length between points which will be laterally restrained.	12.2
Lateral deflection of girder.	f_1	$\pm 0.001 l_b$ generally. $\pm 0.002 l_b$ for members with hollow cross-section. l_b is the total length of girder.	12.2
Maximum bow of web for girders and columns (depth of web h_w , width of flange b).	f_w	$h_w / 150$.	12.3
Inclination of web between upper and lower flanges.	v_w	$h_w / 75$.	12.3
Eccentricity of the web in relation to the center of either flange.	v_{w1}	$b/40 \leq 10$ mm.	12.3
Positional deviation of parts connected to a girder or column e.g., cover plate, base plate etc.	e_1	7 mm in any direction.	12.4

Deviation		a_{max}	Fig.
Positional deviation of adjacent end plates of girders.	e_1	5 mm in any direction.	12.4
Length of prefabricated components to be fitted between other components	Δl_t Δh_c	+ 0.0 - 5 mm.	12.5
Maximum bow of web for plate girders with intermediate stiffeners (depth of web d , thickness of web t_w).	f_w	Least panel dimension /115 For $d/t_w < 150$. Least panel dimension /90 For $d/t_w \geq 150$.	12.3 and 12.6
Flanges of plate girders.	Δ	$\Delta \leq C/250 \leq 6$ mm.	12.7
Unevenness of plates in the case of contact bearing surfaces.		1 mm over a gauge length of 300 mm.	

12.6 PERMISSIBLE DEVIATIONS OF COLUMN FOUNDATIONS

1- The deviation of the center line for anchor bolts within the group of bolts at any column base shall not exceed the following:

- For bolts rigidly cast in, between centers of bolts: $a_1 = 10$ mm in any direction.
- For bolts set in sleeves, between centers of sleeves: $a_1 = 20$ mm in any direction.

2- The distance between two adjacent columns, measured at the base of the steel structure, shall not exceed the value $a_2 = \pm 10$ mm of the nominal distance (Fig.12.8).

3- With column rows, the sum of single deviations a_2 , referred to the length L of the row i shall not exceed the value (Fig. 12.8):

$$\begin{aligned} |a_3| &\leq 15 \text{ mm for } L \leq 30 \text{ m.} \\ |a_3| &\leq 15 + 0.25 (L - 30) \text{ mm for } L > 30 \text{ m (maximum 50 mm).} \end{aligned}$$

12.7 PERMISSIBLE DEVIATIONS OF ERECTED STRUCTURES

Deviation		a_{max}	Fig.
Overall dimensions of the building.	$\sum \Delta h$ or $\sum \Delta L$	± 20 mm for $L \leq 30$ m. $\pm 20 + 0.25 (L - 30)$ mm. For $L > 30$ m (maximum 50 mm).	12.9
Level of top of floor slab. Floor bearing on column.	Δh	± 5 mm.	12.5
Inclination of column in a multi-storey building; maximum deviation for the vertical line between adjacent floor slabs.	v_h	$0.003 h_1$. h_1 = Floor height under consideration.	12.10
Inclination of column in a multi-storey building; maximum deviation for the vertical line through the intended location of the column base.	v_1	$0.0035(\sum h_1)/3/(n+2)$ n = Number of floors.	12.11
Inclination of column in a single-storey residential building; maximum deviation for the vertical line.	v_{h1}	$0.0035 h$ h = Single-storey floor height.	12.12
Inclination of column of a portal frame in an industrial building, (not supporting crane gantry), maximum deviation for the vertical line.	v_{hp1} or v_{hp2}	Individual = v_{hp1} or $v_{hp2} \leq 0.010 h$ Mean = $\frac{(v_{hp1} + v_{hp2})}{2} \leq 0.002 h$	12.13 or 12.14
Unintentional eccentricity of girder bearing.	e_o	5 mm.	12.15
Distance between adjacent steel columns at any level.	Δl_s	± 15 mm.	12.9

Deviation		a_{max}	Fig.
Distance between adjacent steel girders at any level.	Δl_t	± 20 mm.	12.5
Positional deviation of a column base in relation to the column axis through the head of the column below (applied also in the case of indirect load transmission).	e_2	5 mm in any direction.	12.16
Deviation in level of bearing surfaces on steel columns (crane girder level).	Δh_c	+0.0 mm. -10 mm.	12.17
Positional deviation of bearing surfaces.	e_3	± 5 mm.	12.18

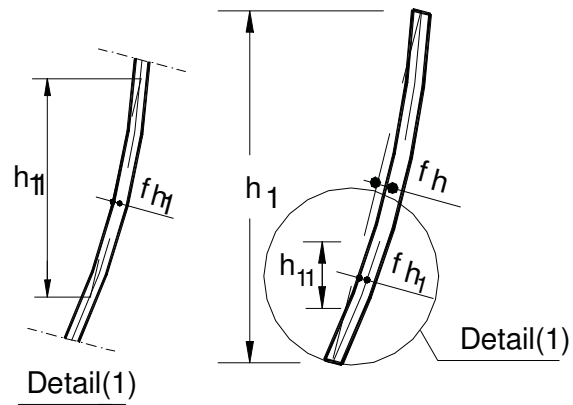


Figure (12.1) Inclination and Deflections of Columns

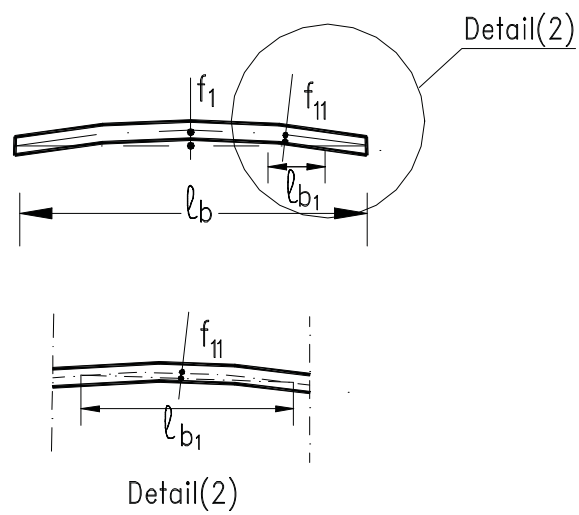


Figure (12.2) Deflection of Girders

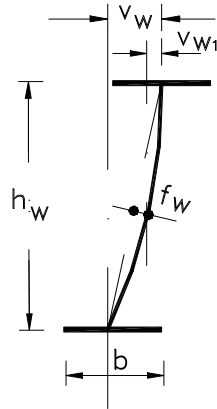


Figure (12.3) Deviations in Welded Girders

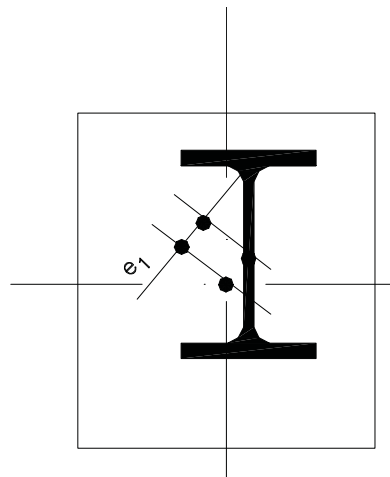


Figure (12.4) Deviation in Connecting Pieces

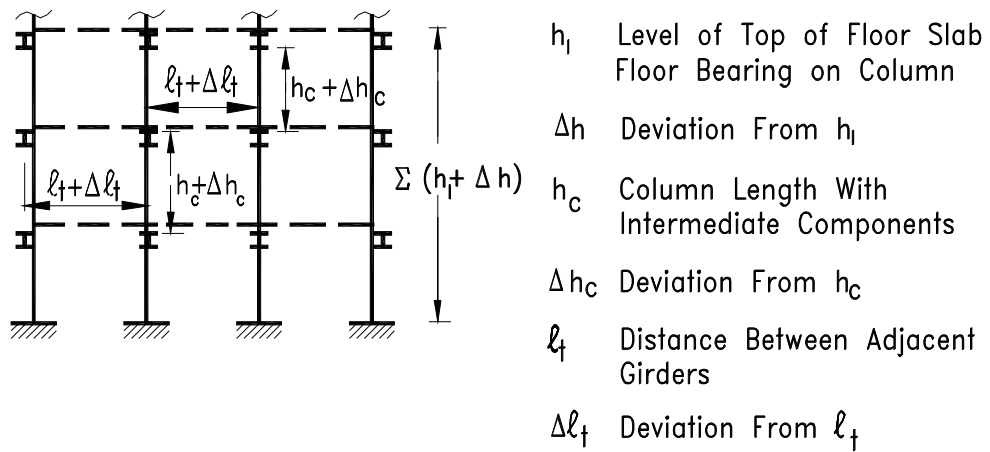


Figure (12.5) Deviation in Height and Length

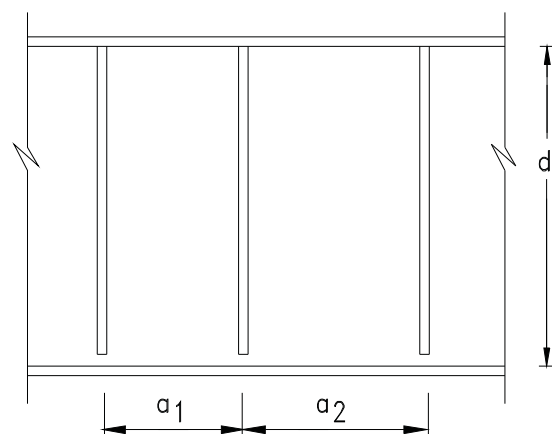


Figure (12.6) Welded Plate Girder

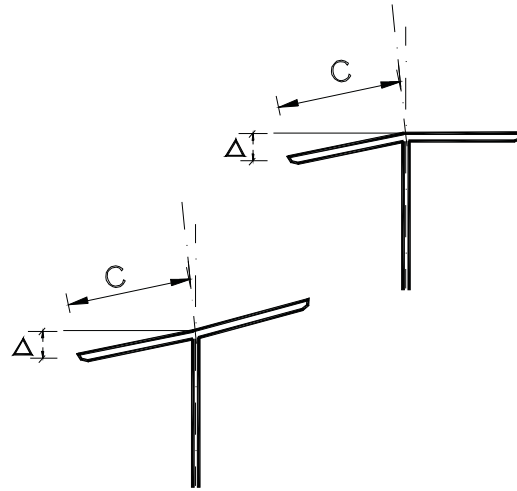


Figure (12.7) Deviation in Flanges of Welded Plate Girders

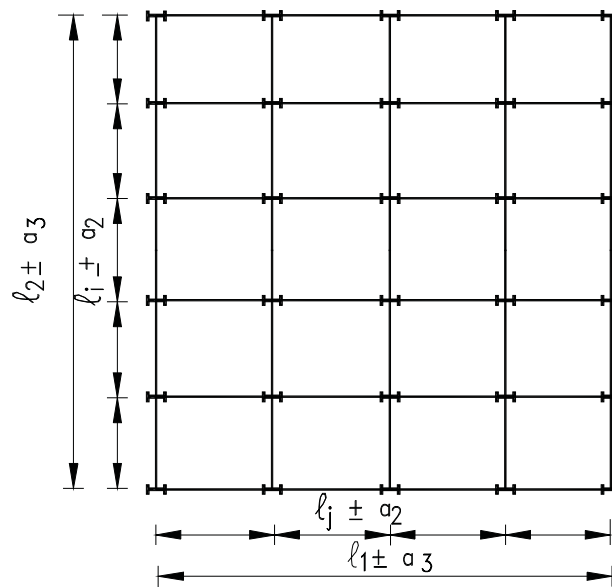


Figure (12.8) Deviation in Length at Base of Steel Structure (Plan)

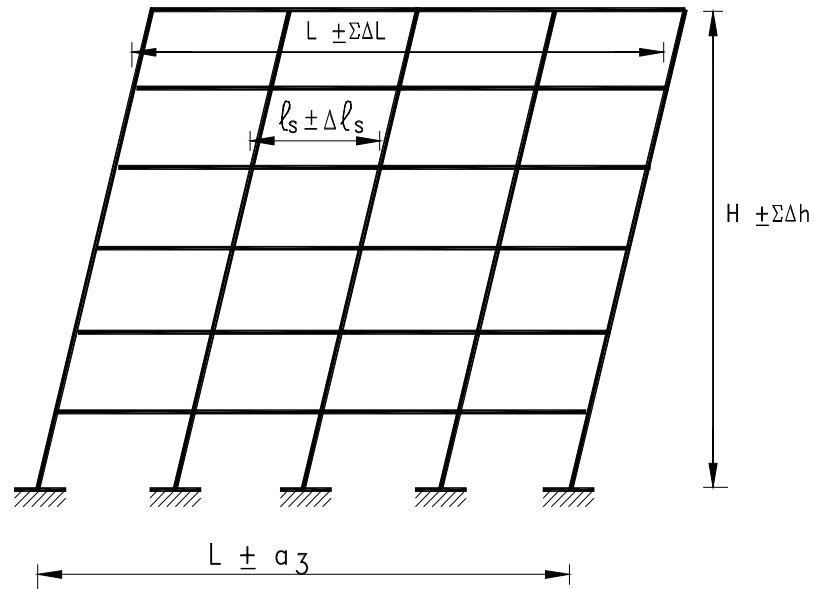


Figure (12.9) Deviation in Length (Vertical Section)

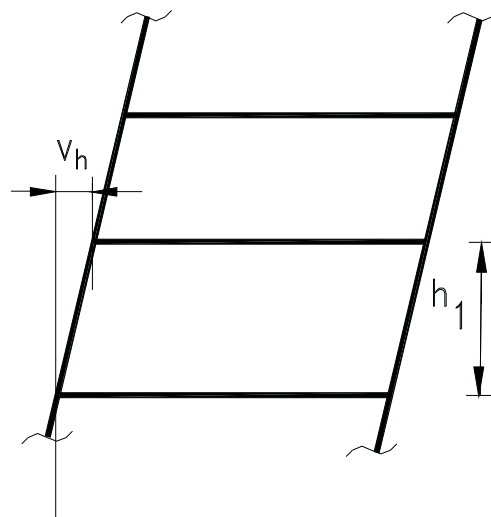


Figure (12.10) Inclination of Column in a Multi-Storey Building

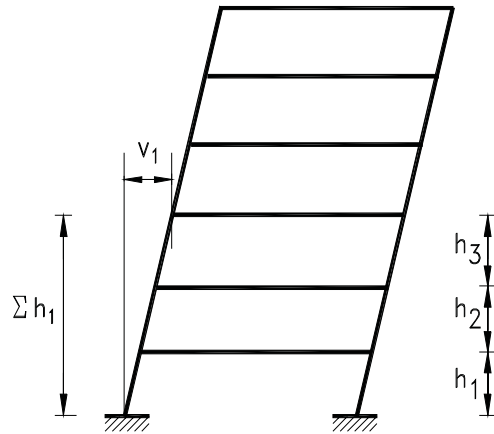


Figure (12.11) Inclination of Column in a Multi-Storey Building

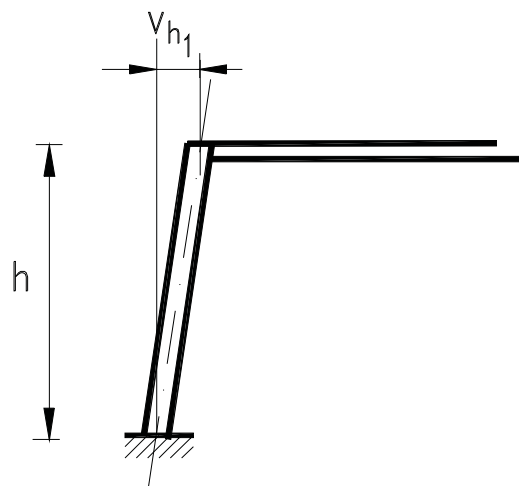


Figure (12.12) Inclination of Column in a Single-Storey Building

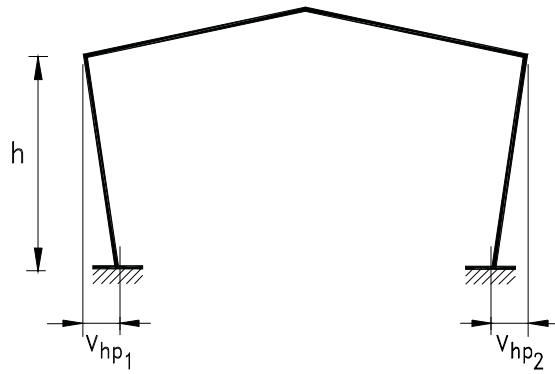


Figure (12.13) Inclination of Column in a Portal Frame

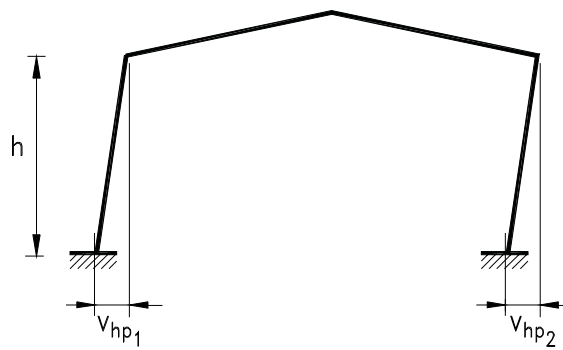


Figure (12.14) Inclination of Column in a Portal Frame

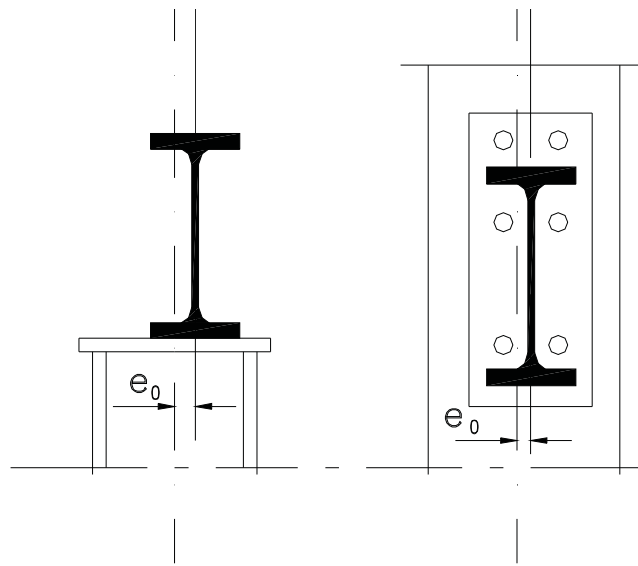


Figure (12.15) Eccentricity of Girder Bearing

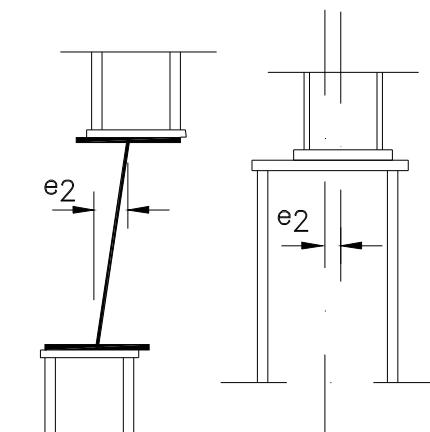


Figure (12.16) Deviations in Columns Splices

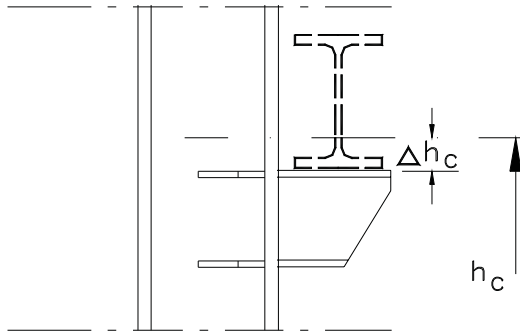


Figure (12.17) Deviations in Level of Bearing Surfaces

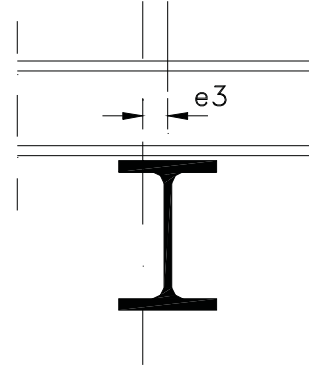


Figure (12.18) Deviation in Position of Bearing Surfaces



CHAPTER 13

FABRICATION ,ERECTION AND FINISHING WORKS

13.1 GENERAL PROVISIONS

13.1.1 Scope

Unless otherwise specified in the Contract Documents, the trade practices that are defined in this Code shall govern the fabrication and erection of steel structures (temporary and permanent).

13.1.2 Responsibility for Design

13.1.2.1 When the Employer's Designated Representative for Design (hereinafter called EDRD) provides the design, design drawings and specifications, the Fabricator and/or the Erector shall be responsible for checking suitability, adequacy and building-code conformance of the design. The Fabricator and/or the Erector shall give prompt notice to the the Employer and EDRD of any error, omission, fault or other defects in the design of or design drawings or specification.

13.1.2.2 When the Employer enters into a direct contract with the Fabricator to both design and fabricate an entire completed steel structure, the Fabricator shall be solely responsible for the suitability, adequacy and building-code conformance of the structural steel design. The Employer shall be responsible for the suitability, adequacy and building-code conformance of the non-structural steel arrangement.

13.1.3 Patents and Copyrights

The entity or entities that are responsible for the specification and/or selection of proprietary structural designs shall secure all intellectual property rights necessary for the use of those designs.



13.1.4 Existing Structures

Unless specifically otherwise specified in the tender documents, the scope of works to be carried out by the Fabricator and /or Erector shall include :

13.1.4.1 Demolition and shoring of any part of an existing structure;

13.1.4.2 Protection of existing structures and its contents and equipment, so as to prevent damage from erection works.

13.1.4.3 Surveying or field dimensioning of relevant existing structures; and

13.1.4.4 Abatement or removal of Hazardous Materials.

Such works shall be performed in a timely manner so as not to interfere with or delay the Fabrication and/or the Erection works.

13.2 SHOP FABRICATION AND DELIVERY

All workmanship shall be of first class quality in every respect. The greatest accuracy shall be observed to ensure that all parts will fit properly together on erection.

13.2.1 Identification Of Material

13.2.1.1 Material ordered to special requirements shall be marked by the supplier prior to delivery to the Fabricator's shop or other point of use.

Material that is ordered to special requirements, but not so marked by the Supplier, shall not be used until:

a- its identification is established by means of testing in accordance with the applicable Egyptian Standard Specifications; and

b- a Fabricator's identification mark, as described in Clause 13.2.1.2 and 13.2.1.3, has been applied.



13.2.1.2 During fabrication, up to the point of assembling members, each piece of material that is ordered to special requirements shall carry a Fabricator's identification mark or an original Supplier's identification mark. The Fabricator's identification mark shall be in accordance with the Fabricator's established identification system, which shall be made available prior to the start of fabrication for the Employer's Designated Representative for Construction (hereinafter called EDRC), the Building-Code Authority and the Inspector.

13.2.1.3 Parts that are made of material that is ordered to special requirements shall not be given the same assembling or erection mark as members made of other material, even if they are of identical dimensions and detail.

13.2.2 Preparation of Material

13.2.2.1 Thermal cutting of structural steel by hand-guided or mechanically guided means is permitted.

13.2.2.2 Surfaces that are specified as "Finished" in the Contract Documents shall have a suitable roughness height value. The use of any fabricating technique that produces such a finish is permitted.

13.2.3 Fitting and Fastening

13.2.3.1 Projecting elements of Connection materials need not be straightened in the connecting plane.

13.2.3.2 Backing bars and runoff tabs shall be used as required to produce sound welds. The Fabricator or Erector need not remove backing bars or runoff tabs unless such removal is specified in the Contract Documents. When the removal of backing bars is specified in the Contract Documents, such removal shall meet the requirements in the *relevant welding specification*. In such cases, hand flame-cutting close to the edge of the finished member with no further finishing is permitted, unless other finishing is specified in the Contract Documents.



13.2.4 Fabrication Tolerances

The tolerances on structural steel fabrication shall be in accordance with the requirements in Chapter 12 of this Code.

13.2.5 Shop Cleaning and Painting

Unless otherwise specified, steel work shall be given one coat of approved red lead paint after it has been accepted and before it is shipped from the works.

Surfaces not in contact, but inaccessible after assembly or erection, shall be painted three coats. The shop contact surfaces shall not be painted. Field contact surfaces shall receive a shop coat of paint, except main splices for chords of trusses and large girder splices involving multiple thickness of material where a shop coat of paint would make erection difficult. Field contact surfaces not painted with the shop coat shall be given a coat of approved lacquer or other protective coating if it is expected that there will be a prolonged period of exposure before erection.

Surfaces, which will be in contact with concrete, shall not be painted.

Structural steel, which is to be welded, shall not be painted before welding is complete. If it is to be welded only in the fabricating shop and subsequently erected by bolting, it shall receive one coat of paint after shop welding is finished. Steel, which is to be field welded, shall be given one coat of boiled linseed oil or other approved protective coating after shop welding and shop fabrication is completed.

Surfaces of iron and steel castings, either milled or finished, shall be given one coat of paint.

With the exception of abutting joints and base plates, machine-finished surfaces shall be coated as soon as practicable after being accepted, with a hot mixture of white lead tallow or other approved coating, before removal from the shop.



Erection marks for field indication of members and weight marks shall be painted upon surface areas previously painted with the shop coat. Material shall not be loaded for shipment until it is thoroughly dry, and in any case not less than 24 hours after the paint has been applied.

Structural steel that does not require shop paint shall be cleaned from any oil or grease with solvent cleaners, and of dirt and other foreign material by sweeping with a fiber brush or other suitable means. For structural steel that is required to be shop painted, the requirements in Clauses 13.2.5.1 through 13.2.5.4 shall apply.

13.2.5.1 The Fabricator is not responsible for deterioration of the shop coat that may result from exposure to exceptional atmospheric or corrosive conditions that are more severe than the normal ones.

13.2.5.2 Unless otherwise specified in the Contract Documents, the Fabricator shall, as a minimum, hand clean the structural steel of loose rust, loose mill scale, dirt and other foreign matters, prior to painting, by means of wire brushing or by other methods selected by the Fabricator. If the Fabricator's workmanship on surface preparation is to be inspected by the Inspector, such inspection shall be performed in a timely manner prior to the application of the shop coat.

13.2.5.3 Unless otherwise specified in the Contract Documents, paint shall be applied by brushing, spraying, rolling, flow coating, dipping or other suitable means, at the election of the Fabricator. When the term "shop coat", "shop paint" or other equivalent term is used with no paint system specified, the Fabricator's standard shop paint shall be applied to a minimum dry-film thickness of one coat [40 micron].

13.2.5.4 Touch-up of abrasions caused by handling after painting shall be the responsibility of the Contractor that performs field painting.



13.2.6 Marking and Shipping of Materials

13.2.6.1 Unless otherwise specified in the Contract Documents, erection marks shall be applied to the structural steel members by painting or other suitable means.

13.2.6.2 Bolt assemblies and loose bolts, nuts and washers shall be shipped in separate closed containers according to length and diameter, as applicable. Pins and other small parts and packages of bolts, nuts and washers shall be shipped in boxes, crates, kegs or barrels. A list and description of the material shall appear on the outside of each closed container.

13.2.7 Delivery of Materials

13.2.7.1 Fabricated structural steel shall be delivered in a sequence that will permit efficient and economical fabrication and erection, and that is consistent with the requirements of the Contract Documents. If the Employer or EDRC wishes to prescribe or control the sequence of delivery of materials, that entity shall specify the required sequence in the Contract Documents. If the EDRC contracts separately for delivery and for erection, the EDRC shall coordinate between contractors.

13.2.7.2 Anchor Rods, washers, nuts and other anchorage or grillage materials that are to be built into concrete or masonry shall be shipped so that they will be available when needed. The EDRC shall allow the Fabricator sufficient time to fabricate and ship such materials before they are needed.

13.2.7.3 If any shortage is claimed relative to the quantities of materials that are shown in the shipping statements, the EDRC or the Erector shall promptly notify the Fabricator so that the claim can be investigated.

13.2.7.4 Unless otherwise specified in the Contract Documents, and subject to the approved Shop and Erection Drawings, the Fabricator shall limit the number of field splices to that consistent with minimum project cost.



13.2.7.5 If material arrives at its destination in damaged condition, the receiving entity shall promptly notify the Fabricator and Carrier prior to unloading the material, or promptly upon discovery prior to erection.

13.3 ERECTION

13.3.1 Method of Erection

Fabricated Structural Steel shall be erected using methods and a sequence that will permit efficient and economical performance of erection, and that is consistent with the requirements of the Contract Documents. If the EDRC wishes to prescribe or control the method and/or sequence of erection, or specifies that certain members cannot be erected in their normal sequence, the required method and sequence has to be specified in the Contract Documents. If the EDRC contracts separately for fabrication services and for erection services, the EDRC shall coordinate between contractors.

13.3.2 Job-Site Conditions

The EDRC shall provide and maintain the following for the Fabricator and the Erector:

- a-** Adequate access roads into and through the job site for the safe delivery and movement of the material to be erected and of derricks, cranes, trucks and other necessary equipment .
- b-** A firm, properly graded, drained, convenient and adequate space at the job site for the operation of the Erector's equipment, free from overhead obstructions, such as power lines, telephone lines or similar conditions; and
- c-** Adequate storage space, when the structure does not occupy the full available job site, to enable the Fabricator and/or the Erector to operate a practical speed. Otherwise, the EDRC shall inform the



Fabricator and the Erector of the actual job-site conditions and/or special delivery requirements in the tender documents.

13.3.3 Foundations, Piers and Abutments

The location, strength and suitability of, and access to, all foundations, piers and abutments shall be the responsibility of the EDRC.

13.3.4 Building Lines and Bench Marks

The EDRC shall be responsible for the accurate location of building lines and bench-marks at the job site and shall furnish the Erector with a plan that contains all such information. The EDRC shall establish offset building lines and reference elevations at each level for the Erector's usage in the positioning of adjustable Items (see Clause 13.3.13), if any.

13.3.5 Installation of Anchor Bolts, Foundation Bolts and other embedded Items

13.3.5.1 Anchor rods, foundation bolts and other embedded items shall be set by the EDRC in accordance with an approved Embedment Drawing. The variation in location of these items from the dimensions shown in the Embedment Drawings shall be as mentioned in Clause 12.6

13.3.5.2 Unless otherwise specified in the Contract Documents, Anchor Rods shall be set with their longitudinal axis perpendicular to the theoretical bearing surface.

13.3.5.3 Embedded items and connection materials that are part of the work of other trades, but that will receive Structural Steel, shall be located and set by the EDRC in accordance with an approved Embedment Drawing. The variation in location of these items shall be limited to a magnitude that is consistent with the tolerances that are specified in Clause 13.3.5.1 for the erection of the Structural Steel.



13.3.5.4 All work that is performed by the EDRC shall be completed so as not to delay or interfere with the work of the Fabricator and/or the Erector.

The EDRC shall conduct a survey of the as-built locations of Anchor Rods, foundation bolts and other embedded items, and shall verify that all items covered in Clause 13.3.5.1 meet the corresponding tolerances. When corrective action is necessary, the EDRC shall obtain the guidance and approval of the EDRD.

13.3.6 Installation of Bearing Devices

All leveling plates, leveling nuts and washers and loose base and bearing plates that can be handled without a derrick or crane are set to line and grade by the EDRC. Loose base and bearing plates that require handling with a derrick or crane shall be set by the Erector to lines and grades established by the EDRC. The Fabricator shall clearly scribe loose base and bearing plates with lines or other suitable marks to facilitate proper alignment. Promptly after the setting of Bearing Devices, the EDRC shall check them for line and grade. The variation in elevation relative to the established grade for all Bearing Devices shall be equal to or less than plus or minus 3 mm. The final location of Bearing Devices shall be the responsibility of the Erector.

13.3.7 Grouting

Grouting shall be the responsibility of the Erector. Leveling plates and loose base and bearing plates shall be promptly grouted after they are set, checked for line and grade, and approved by EDRC. Columns with attached base plates, beams with attached bearing plates and other similar members with attached bearing devices that are temporarily supported on leveling nuts and washers, shims or other similar leveling devices, shall be promptly grouted after the Structural Steel frame or portion thereof has been plumbed.



13.3.8 Field Connection Material

13.3.8.1 The Fabricator shall provide field connection details that are consistent with the requirements of the Contract Documents and that will result in economical fabrication and erection.

13.3.8.2 When the Fabricator is responsible for erecting the Structural Steel, the Fabricator shall furnish all materials that are required for both temporary and permanent Connection of the component parts of the Structural Steel frame.

13.3.8.3 When the erection of the Structural Steel is not performed by the Fabricator, the Fabricator shall furnish the following field Connection material:

- a-** Bolts, nuts and washers of the required grade, type and size in sufficient quantity for all Structural Steel-to-Structural Steel field connections that are to be permanently bolted, including an extra 2 percent of each bolt size (diameter and length);
- b-** Shims that are shown as necessary for make-up of permanent structural steel-to-structural steel connections; and,
- c-** Backing bars and run-off tabs that are required for field welding.

13.3.8.4 The Erector shall furnish all welding electrodes, fit-up bolts and drift pins used for the erection of the Structural Steel.

13.3.9 Loose Material

Unless otherwise specified in the Contract Documents, loose Structural Steel items that are not connected to the Structural Steel frame shall be set by the Erector.

13.3.10 Temporary Support of Structural Steel Frames

13.3.10.1 The EDRD shall identify the following in the Contract Documents:



a- The lateral-load-resisting system and connecting diaphragm elements that provide for lateral strength and stability in the completed structure; and,

b- Any special erection conditions or other considerations that are required by the design concept, such as the use of shores, jacks or loads that must be adjusted as erection progresses to set or maintain camber, position within specified tolerances or pre-stress.

13.3.10.2 The EDRD shall indicate to the Erector , in the tender documents, the installation schedule for non-Structural Steel elements of the lateral-load-resisting system and connecting diaphragm elements identified in the Contract Documents.

13.3.10.3 Based upon the information provided in accordance with Clauses 13.3.10.1 and 13.3.10.2, the Erector shall determine, furnish and install all temporary supports, such as temporary guys, beams, falsework, cribbing or other elements required for the erection operation. These temporary supports shall be sufficient to secure the bare Structural Steel framing or any portion thereof against loads that are likely to be encountered during erection, including those due to wind and those that result from erection operations.

13.3.10.4 All temporary supports that are required for the erection operation and furnished and installed by the Erector shall remain the property of the Erector and shall not be modified, moved or removed without the consent of the Erector. Temporary supports provided by the Erector shall remain in place until the portion of the Structural Steel frame that they brace is complete and the lateral-load-resisting system and connecting diaphragm elements identified by the EDRD in accordance with Clause 13.3.10.1 are installed. Temporary supports that are required to be left in place after the completion of Structural Steel erection shall be removed when no longer needed by the EDRD and returned to the Erector.



13.3.11 Safety Protection

13.3.11.1 The Erector shall provide floor coverings, handrails, walkways and other safety protection for the Erector's personnel as required by law and applicable safety regulations. Unless otherwise specified in the Contract Documents, the Erector is permitted to remove such safety protection from areas where the erection operations are completed and approved by EDRC.

13.3.11.2 When safety protection provided by the Erector is left in an area for the use of other trades after the Structural Steel erection activity is completed, the EDRC shall:

- a-** Indemnify the Fabricator and/or the Erector from damages that may be incurred from the use of this protection by other trades;
- b-** Ensure that this protection is adequate for use by other affected trades;
- c-** Ensure that this protection complies with applicable safety regulations when being used by other trades; and
- d-** Instruct the Fabricator and/or the Erector remove this protection when it is no longer required.

13.3.11.3 Safety protection for other trades that are not under the direct employment of the Erector shall be the responsibility of the EDRC.

13.3.11.4 When permanent steel decking is used for protective flooring and is installed by the EDRC all such work shall be scheduled and performed in a timely manner so as not to interfere with or delay the work of the Fabricator or the Erector

13.3.11.5 Unless the interaction and safety of activities of others, such as construction by others or the storage of materials that belong to others, are coordinated with the work of the Erector by the EDRC, such activities shall not be permitted until the erection of the



Structural Steel frame or portion thereof is completed by the Erector and accepted by the EDRC.

13.3.12 Structural Steel Frame Tolerances

The accumulation of the mill tolerances and fabrication tolerances shall not cause the erection tolerances to be exceeded.

13.3.13 Erection Tolerances

Erection tolerances shall be defined relative to member working points and working lines, which shall be defined as follows:

- a-** For members other than horizontal members, the member work point shall be the actual center of the member at each end of the shipping piece.
- b-** For horizontal members, the working point shall be the actual centerline of the top flange or top surface at each end.
- c-** The member working line shall be the straight line that connects the member working points.

The substitution of other working points is permitted for ease of reference, provided they are based upon the above definitions. The tolerances on Structural Steel erection shall be in accordance with the requirements in Chapter 12 of this Code.

13.3.14 Correction of Errors

The correction of minor misfits by moderate amounts of reaming, grinding, welding or cutting, and the drawing of elements into line with drift pins, shall be considered to be normal erection operations. Errors that cannot be corrected using the foregoing means, or that require major changes in member or connection configuration, shall be promptly reported to the EDRD and EDRC and the Fabricator by the Erector, to enable the responsible entity to either correct the error or approve the most efficient and economical method of correction to be used by others.



13.3.15 Cuts, Alterations and Holes for other Trades

Neither the Fabricator nor the Erector shall cut, drill or otherwise alter their work, nor the work of other trades, to accommodate other trades, unless such work is clearly specified in the Contract Documents. When such work is so specified, the EDRD and EDRC shall furnish complete information as to materials, size, location and number of alterations in a timely manner so as not to delay the preparation of Shop and Erection Drawings.

13.3.16 Handling and Storage

The Erector shall take reasonable care in the proper handling and storage of the Structural Steel during erection operations to avoid the accumulation of excess dirt and foreign matter. The Erector shall be responsible for the removal from the Structural Steel of dust, dirt or other foreign matter that may accumulate during erection as the result of job-site conditions or exposure of the elements.

13.3.17 Field Painting

The Erector is responsible to paint field bolt heads and nuts or field welds, nor to touch up abrasions of the shop coat, nor to perform any other field painting.

13.3.18 Final Cleaning Up

Upon the completion of erection and before final acceptance, the Erector shall remove all of the Erector's falsework, rubbish and temporary buildings.

13.4 QUALITY ASSURANCE

13.4.1 General

13.4.1.1 The Fabricator shall maintain a quality assurance program to ensure that the work is performed in accordance with the requirements of this Code and the Contract Documents



13.4.1.2 The Erector shall maintain a quality assurance program to ensure that the work is performed in accordance with the requirements of this Code and the Contract Documents. The Erector shall bear the costs of performing the erection of the Structural Steel, and shall provide all necessary equipment, material, personnel and management for the scope, magnitude and required quality of each project .

13.4.2 Inspection of Mill Material

Certified mill test reports shall constitute sufficient evidence that the mill product satisfies material order requirements. The Fabricator shall make a visual inspection of material that is received from the mill, but need not perform any material tests unless the EDRD specifies in the Contract Documents that additional testing is to be performed.

13.4.3 Non-Destructive Testing

When non-destructive testing is required, the process, extent, technique and standards of acceptance shall be clearly specified in the Contract Documents.

13.4.4 Surface Preparation and Shop Painting Inspection

Inspection of surface preparation and shop painting shall be planned for the acceptance of each operation as the Fabricator completes it. Inspection of the paint system, including material and thickness, shall be made promptly upon completion of the paint application. When wet-film thickness is to be inspected, it shall be measured during the application.

13.4.5 Independent Inspection

When inspection by personnel other than those of the Fabricator and/or Erector is specified in the Contract Documents, the requirements in Clauses 13.4.5.1 through 13.4.5.6 below shall be met.



13.4.5.1 The Fabricator and/or the Erector shall provide the Inspector with access to all places where the work is being performed. A minimum of 24 hours notification shall be given prior to the commencement of work.

13.4.5.2 Inspection of shop work by the Inspector shall be performed in the Fabricator's shop to the fullest extent possible. Such inspections shall be timely, in-sequence and performed in such a manner as will not disrupt fabrication operations and will permit the repair of non-conforming work prior to any required painting while the material is still in-process in the fabrication shop.

13.4.5.3 Inspection of field work shall be promptly completed without delaying the progress or correction of the work.

13.4.5.4 Rejection of material or workmanship that is not in conformance with the Contract Documents shall be permitted at any time during the progress of the work.

13.4.5.5 The Fabricator and/or the Erector shall be informed of deficiencies that are noted by the Inspector promptly after the inspection. Copies of all reports prepared by the Inspector shall be promptly given to the Fabricator and/or the Erector. The necessary corrective work shall be performed in a timely manner.

13.4.5.6 The Inspector shall not suggest, direct, or approve the Fabricator and/or Erector to deviate from the Contract Documents or the approved Shop and Erection Drawings, or approve such deviation, without the written approval of the EDRD and EDRC.



13.5 CONTRACTS

13.5.1 Types of Contracts

13.5.1.1 For contracts that stipulate a lump sum price, the work that is required to be performed by the Fabricator and/or the Erector shall be completely defined in the Contract Documents.

13.5.1.2 For contracts that stipulate a price per ton, the scope of work that is required to be performed by the Fabricator and/or the Erector, the type of materials, the character of fabrication and the conditions of erection shall be based upon the Contract Documents, which shall be representative of the work to be performed.

13.5.1.3 For contracts that stipulate a price per item, the work that is required to be performed by the Fabricator and/or the Erector shall be based upon the quantity and the character of the items that are described in the Contract Documents.

13.5.1.4 For contracts that stipulate unit prices for various categories of Structural Steel, the scope of work required to be performed by the Fabricator and the Erector shall be based upon the quantity, character and complexity of the items in each category as described in the Contract Documents, and shall also be representative of the work to be performed in each category.

13.5.2 Calculation of Weights

Unless otherwise specified in the contract, for contracts stipulating a price per ton for fabricated Structural Steel that is delivered and/or erected, the quantities of materials for payment shall be determined by the calculation of the gross weight of materials as shown in the Shop Drawings.

13.5.2.1 The unit weight of steel shall be taken as 7850 kg/m^3 . The unit weight of other materials shall be in accordance with the manufacturer's published data for the specific product.



13.5.2.2 The weights of Standard Structural shapes, plates and bars shall be calculated on the basis of Shop Drawings that show the actual quantities and dimensions of material to be fabricated, as follows:

- a-** The weights of all Standard Structural shapes shall be calculated using the nominal weight per meter and the detailed overall length.
- b-** The weights of plates and bars shall be calculated using the detailed overall rectangular dimensions.
- c-** When parts can be economically cut in multiples from material of larger dimensions, the weight shall be calculated on the basis of the theoretical rectangular dimensions of the material from which the parts are cut.
- d-** When parts are cut from Standard Structural shapes, leaving a non-standard section that is not useable on the same contract, the weight shall be calculated using the nominal weight per meter and the detailed overall length of the Standard Structural shapes from which the parts are cut.
- e-** Deductions shall not be made for material that is removed for cuts, copes, clips, blocks, drilling, punching, boring, slot milling, planing or weld joint preparation.

13.5.2.3 The weights of shop or field weld metal and protective coatings shall not be included in the calculated weight for the purposes of payment.

13.5.3 Revisions to the Contract Documents

Revisions to the Contract Documents shall be confirmed by variation or change order or extra work order. Unless otherwise noted, the issuance of a revision to the Contract Documents shall constitute authorization by the Employer that the revision is released for construction. The contract price and schedule shall be adjusted in accordance with Clauses 5.4 and 5.5.



13.5.4 Contract Price Adjustment

13.5.4.1 When the scope of work and responsibilities of the Fabricator and/or the Erector are changed from those previously established in the Contract Documents, an appropriate modification of the contract price shall be made. In computing the contract price adjustment, the Fabricator and the Erector shall consider the quantity of work that is added or deleted, the modifications in the character of the work and the timeliness of the change with respect to the status of material ordering, detailing, fabrication and erection operations.

13.5.4.2 Requests for contract price adjustments shall be presented by the Fabricator and/or the Erector in a timely manner and shall be accompanied by a description of the change that is sufficient to permit evaluation and timely approval by the Employer.

13.5.4.3 Price-per-ton and price-per-item contracts shall provide for additions or deletions to the quantity of work that are made prior to the time the work is released for construction. When changes are made to the character of the work at any time, or when additions and/or deletions are made to the quantity of the work after it is released for detailing, fabrication or erection, the contract price shall be equitably adjusted.

13.5.5 Scheduling

Design Drawings will be released for construction, if such Design Drawings are not available at the time of bidding, and/or when the job site, foundations, piers and abutments will be ready, free from obstructions and accessible to the Erector, so that erection can start at the designated time and continue without interference or delay caused by the EDRC or other trades.

13.5.5.2 The Fabricator and/or the Erector shall advise the Employer's EDRC and EDRD, in a timely manner, of the effect any revision has on the contract schedule.



13.5.5.3 If the fabrication or erection is significantly delayed due to revisions of the requirements of the contract, or for other reasons that are the responsibility of others, the Fabricator and/or Erector shall be compensated for the additional time and/or costs incurred (if any).

13.5.6 Terms of Payment

Terms of payment for the contract shall be as stated in the Contract Documents.



CHAPTER 14

INSPECTION AND MAINTENANCE OF STEEL BRIDGES

14.1 GENERAL

Steel Bridges are subject to gradual deterioration due to corrosion, mechanical wear, impact, and fatigue damage from moving loads, that require periodic maintenance throughout their service life.

The damage likely to get worse or to expose the security of the structure to danger, should be repaired as quickly as possible in all cases.

14.2 INSPECTION

The inspection of steel bridges may be classified as periodic inspection and special or detailed inspection.

14.2.1 Periodic Inspection

This kind of inspection should be made at frequent, scheduled intervals depending on the condition, age of the bridge, and type of traffic. Generally this inspection is made annually or every other year and covers the following points:

- a-** General condition of paint on the entire steel structure.
- b-** Condition of the parts of the frame work with which the construction design allows water to rest in contact for prolonged periods or parts which may undergo the aggressive action of outside agents as smoke of trains.
- c-** The state of rivets, bolts, welds in floor beams' connections, and also those in splices of main girders or connecting web members to upper and lower chord member in trusses.
- d-** Condition of the gusset plates especially in old bridges where



itches and edge distances of rivets may be found to exceed allowable maximum values.

e- State of end components of the bridge in contact with the abutments or supported on piers causing destruction of these walls or components directly supported on piers.

f- Condition of bearings as well as the components of the machinery of movable bridges.

g- State of the retaining walls and piers, and their foundations.

h- State of the track especially its alignment and location with reference to the steel structure at ends and at centre of each span .

i- Condition of the deck concerning:

- 1 - guard rails.
- 2 - side walks and railings.
- 3 - ballast bedding and its depth.
- 4 - waterproofing.

14.2.2 Special or Detailed Inspection

Steel bridges shall undergo detailed inspection at least once every **4-6** years. This inspection shall cover the following points:

a- Location and number of rivets and bolts that are loose and of rivets that have badly corroded heads, paying special attention to floor connections.

b- Welds on lateral bracing and cross frames, stiffeners and other welded details must be examined.

c- State of movable bearings and the clearance between expansion ends, sub-structures or adjoining spans. Special care must be given to investigate if there is any apparent movement (rotation, displacement,...) of the sub-structures.

d- Condition of members as to loss of section due to corrosion,



noting exact location and extent of such action. Measurement of remaining section if members are badly corroded and paying attention to loss of metal in girders, beam flanges, webs, as well as parts of lateral bracing system.

e- Check of piers and abutment levels, especially for bridges crossing rivers.

f- Permanent deflection shall be measured for bridge decks more than **15.0** m span, and compared with previous values to ensure that there is no creep.

14.2.3 Inspection Sketch for Identification of Members

Typical sketches are to be prepared by inspector to show correct identity and location of parts or members described in their inspection report. Photographs shall be used to show critical conditions and to amplify the value of the report.

14.2.4 Files of Bridges

There must be a file for each bridge containing the following:

- 1- Type and origin of materials and tests carried out before construction.
- 2- Type of foundation and soil investigation report.
- 3- Detailed as built drawings of all parts of the bridge.
- 4- The calculation notes.
- 5- The priced bill of quantities used.
- 6- Results of tests and comparison with theoretical calculations.
- 7- Possible incidences taking place during construction.
- 8- Maintenance carried out especially dates when the bridge was repaired or strengthened.



9- Repairs or alterations made during services.

10- Reports of inspections carried out.

11- Photographic documents on the construction phases as those, which may concern different defects or damage.

14.3 MAINTENANCE OF STEEL BRIDGES

14.3.1 Maintenance of Structural Elements

14.3.1.1 Normal maintenance must include periodical cleaning of all exposed surfaces by compressed air.

14.3.1.2 Parts which are exposed to direct attack by smoke or the projection of aggressive products as salts, solvents.. etc., should be protected.

14.3.1.3 Holes or cracks in the substructure can be maintained by appropriate grouting or proper use of epoxy or epoxy mortar.

14.3.1.4 Scouring in river bed must be stopped . Special measures of river treatment and regulation might be necessary.

14.3.1.5 It is necessary to ensure that neither water can exist on surface of the bridge nor be allowed to accumulate in any member of the structure. Drainage holes with reasonable diameters must be provided to this effect.

14.3.1.6 Painting

a- For structures not greatly exposed to corrosion, the life of well applied paint is at least (8-10) years. Intermediate maintenance operations may be resorted to, for parts of the structure which are severely exposed to rust or for which this period would be harmful.

b- Where the paint is to be maintained on steel surfaces, the steel shall be prepared and painted with the recommendations of the



relevant Egyptian Standard Specification.

c- Structures where paint is worn off before the **8-10** years period, shall undergo special inspections to decide if the time between two successive general painting operations should be reduced or if it would be necessary to apply special paint.

d- The bearing areas of the stringers for wooden sleepers should be repainted every time the wooden parts are replaced and every time the structure is repainted. For this purpose bituminous paints give best results.

14.3.1.7 Riveting and Bolting

Loose rivets are detected by the finger and hammer test. Very loose rivets are recognised by the visible ring of rust they have around their heads. Loose rivets must be replaced by high-strength bolts as these give stronger connections. If there are some loose rivets in a splice, it is better to replace all the rivets in the splice by new high strength bolts to get a homogeneous splice. After the final tightening of the bolts, they must be painted by the usual paint. During the detailed inspection of bridges with high-strength bolt connections, the torque of the tightening of these bolts should be checked by a calibrated wrench.

14.3.1.8 Play in the Assembled Units

The increase of the traffic loads leads to higher stresses in rivets of old bridges, as, they have often badly reamed holes or badly filled holes. Under impact, these holes take an oval shape and the connected parts slide in the direction of their own stress, developing a sort of play.

These faults should be discovered at an early stage as they appear during the running of traffic, and may often need the replacement of the defected parts.

14.3.1.9 Cracks in Old Bridges

It is not recommended to weld a crack in a riveted girder, since,



with time this shall cause other cracks, however welding may be used in cases where riveting or bolting is not possible. The cracked part can be replaced by a new part or the crack can be covered with a riveted or bolted cover plate. The crack propagation may be stopped by drilling 15 mm holes at either end of the crack. Besides, the splice plate ends must be in low stress range areas.

14.3.1.10 Bearings

a- Sliding bearings

During periodic maintenance the sliding plate must be cleaned to eliminate all deposits or rust which might lessen their function. For bridges 15 m span or more, the sliding bearings must be lubricated. The main girders should be well seated on the bearing plates. Any play should be eliminated by putting temporary steel packing of a thickness corresponding to the amount of play, to provide the necessary contact. It is also important to ensure the anchorage of the bridge and the maintenance of the level of the track at both ends.

The use of elastomeric bearings should be generalised instead of the steel bearings, as they are found to stop dislocation of bearing with respect to abutments. Broken bearing plates must be replaced, unless the break isolates only a negligible part of the surface.

b- Roller bearings

During periodic maintenance all roller surfaces and their joints as well as the bearing plates must be cleaned and lubricated. When the bridge is repainted care must be taken to prevent any deposits or projection of paint blocking the bearings when it dries. Badly located rollers or rockers, which have fallen over, should be placed in their correct position, after lifting the bridge. The engineer should decide the suitable time and the ambient temperature for which the rollers should be placed in their correct mean position. If the roller bearings are not provided with end wider discs, or strong side bars, they are liable to move sideways, and thus it is recommended to provide such fittings.



14.3.1.11 Jacking of Bridges for Bearing Replacement

It is recommended to foresee in the initial design of steel bridges some reservations to allow for lifting operations required to replace damaged bearings. If, as for old bridges, jacking-up is not foreseeable, it may be necessary to add new temporary structural elements such as: short corbels, lifting brackets or niches to accommodate the jacks. In case the available under beams height does not allow the positioning of normal jacks, flat jacks may be used instead. Steel bridge components may require strengthening before the start-up of jacking in order to prevent damage of the existing structure. The lifting-up and bringing down into position operations should be carried out under continuous monitoring, follow-up and engineering supervision by qualified personnel making available to them the appropriate equipment.

Splitting of bearing, broken rollers may result in cracks and settlement of the superstructure. Deciding on the type of new bearings should be carefully studied considering the following factors: the height of old versus the new bearings, force transmission particularly those acting in the horizontal direction, also the stability of the sub structure components. Jacks should preferably rest on Teflon plates to eliminate any horizontal reactions that may induce additional stresses in the superstructure. The cylinder capacity of the jack is to be calculated from the maximum reaction including live load and impact, if the works are performed under normal traffic conditions and only for dead loads if traffic is interrupted. Should the calculated reactions exceed the actual values, one has to consider, for safety purpose, the higher of them both.



Subject Index for the Egyptian Code of Practice for Steel Construction and Bridges (ECP 2001)

<u>Subject</u>	<u>Page No. in the Code</u>
A	
allowable stress	1, 6-32, 36-41, 122
anchor bolts	114, 217, 236
B	
base plate	144, 215, 216, 232, 237
batten plates	130, 134-141, 178
bearing	4, 94-113, 124, 125
bending moment	21, 26, 64, 108, 114, 118, 123, 137, 145, 156, 161, 167, 185
bracing	6, 7, 8, 51, 52, 64, 128, 144, 146-148, 185, 210, 250, 251
buckling factor	14, 21, 23, 24, 52, 60, 188
buckling length	51-66, 125, 128, 129, 180, 193, 194
built-up sections	22, 152, 177, 210, 211
built up-weld	80, 87
bolts	3, 5, 28, 38, 39, 49, 94-118, 129, 134, 136, 143, 149, 194, 205, 207, 212, 217, 234, 236, 237, 238, 249, 250, 253
C	
camber	129, 239
cantilever	65, 66, 67, 132, 186, 192
centrifugal	6, 29, 30, 146
clearance	95, 96, 101, 103, 139, 145, 147, 205, 214, 250
coefficients	20, 180, 188
cold-formed	133, 183-204
- beams	152-154, 158
- columns	177-180
- beam-columns	181
columns	60, 61, 63, 119, 124, 132, 143, 177-181, 186, 216-227, 237
compact	8, 15-30
composite	152-182
compression	8-31, 35, 51-90, 98, 99, 118-125, 128-130, 133-148, 152-181, 183-213, 216



compression flange	16-19, 63-66, 88, 118, 123-126, 147-151, 152, 153, 159, 216
connections	7, 8, 36, 40, 68, 74, 81, 82, 87, 88, 91, 94-119, 127, 129, 130, 131-143, 179, 194-205, 238, 249, 250, 253
copies	246
crane	8, 37, 38, 40, 105, 106, 132, 144, 214, 218, 219, 235, 237
crippling	22, 25, 119, 186

D

deflection	4, 6, 54, 60, 126, 127, 132-148, 155, 161, 162, 185, 186, 216, 220, 251
depth	7, 14, 17, 19, 78, 88, 90, 93, 118, 127, 129, 140, 141, 145, 146, 155, 161, 162, 164, 168, 185, 209
deviation	214-228, 244
diaphragm	130, 133, 139, 239
distortion	7, 73, 77, 120

E

earthquake	6, 29, 30, 146
eccentricity	7, 15, 127, 131, 141, 216, 218, 227
edge distance	90, 97, 98, 100, 200, 205, 206, 208, 250
effective	19, 78, 83, 91, 122, 127, 134, 154, 197, 199, 204
effective area	13-17, 27, 28, 83, 101, 129, 131, 140-143, 185-189, 194, 195
effective length	19, 51-66, 84-88, 128, 136, 193
effective stress	38, 84
effective width	21, 23, 24, 156, 158, 161, 183-187
end plate	114-121, 217
equivalent	27, 115, 117, 138, 158, 232
erection	1, 8, 139, 146, 214, 229-248
expansion	1, 2, 33, 148, 162, 250

F

fabrication	1, 68, 139, 215, 229-248
-------------	--------------------------



fatigue	35-39, 79,92, 214, 249
fillet weld	71-92, 118, 196, 200, 201, 202
frames	4, 26, 52-64, 127, 128, 132, 147, 148, 186, 238, 250
framing	239

G

girders	7, 28, 54-64, 87, 105, 122-126, 128, 132, 139-148, 156, 216-223
groove weld	74-92, 196, 197, 202, 204

H

hanger	52
heat	94, 196
high strength	39, 94--114, 253
hinges	3, 31, 136
holes	27, 28, 36, 88, 95-110, 140, 141, 205, 206, 242, 252-254
hybrid	114, 131

I

impact	37, 97, 109, 150, 249-255
intermittent	40, 73, 87, 88, 89

J

joints	82-92, 105, 109, 112, 113, 127, 131, 149, 197, 200, 202, 232, 246, 254
--------	--

K

K factor	62
----------	----



L

lacing bars	130, 133-141
lamellar	91, 93
lateral	6, 16-30, 51-67, 128, 146-149, 153-178, 216, 239, 250, 251
loads	6, 8-30, 35-60, 68-88, 105, 143, 154-168, 186, 198, 239, 249-255

M

modular ratio (n)	158
modulus	2, 32, 54, 158, 162, 175-180, 195
moment	8, 13-28, 54-64, 108, 114-118, 122-125, 127, 136-145, 153-181, 185-212

N

net area	13, 27, 129, 141-143, 183, 194
non compact	8, 15-30, 128, 183
nuts	3, 95, 96, 234, 237, 238, 242

O

overhead crane	214
oversize hole	95
out of	96, 111

P

partial penetration	77, 92, 93
penetration	75-92, 209
plate girders	28, 87, 122-126, 139--148, 217, 223
plug	88, 90
prying	107, 108, 114-118



Q

Q (shear force)	166
quality assurance	242, 243

R

rails	144, 149, 150, 186, 240, 250
rivets	1, 5, 95, 97, 134, 136, 140, 212, 249, 250, 253

S

screws	3, 149, 207, 209, 210
shear	2, 5, 8-30, 79, 84, 88, 94-114, 122-126, 136, 148, 152-177, 186, 192, 198-212
shear connectors	152-176
shoring	152, 156, 158, 162, 230
slender	13-21, 52, 122, 185, 186
slenderness ratio	15, 28, 51, 129, 133-144, 180, 183, 193, 194
slot	36, 95, 99, 100, 206
slot welds	88, 90
spacing	14, 88, 90, 98, 99, 122, 127, 156, 165-178, 205-213
splices	126-130, 143, 196, 227, 232, 234, 249
stiffened-stiffener	9, 14, 21, 23, 25, 64, 87, 88, 119, 122-126, 147, 183-192, 27, 250

T

temperature	2, 6, 29, 30, 69, 73, 148, 162, 163, 254
tension	13, 16-31, 51, 52, 77-89, 94-119
thread	96, 101, 114, 207
tie rods	114
tightening	95-114, 253
tolerance	214, 215, 232-241



torsion	18, 19, 27, 66, 67, 148, 153, 164
truss	7, 40, 52-55, 127-129, 131-148, 232, 249
turn	109, 110, 127, 239
U	
unbraced	21, 53, 64, 128, 210
V	
V-notch	69
W	
washers	95, 96, 112, 113, 197, 206, 209, 234, 237, 238
wall	144, 154, 179, 194, 250
web	7, 13-30, 40, 87, 111-120, 122-125, 128-130, 131-146, 153-176, 184-217, 249, 251
welding	36, 68-92, 95, 114, 133-143, 168, 204, 231-241, 254
wind	6, 7, 8, 29, 30, 35, 127, 146-148, 186, 239
Y	
yield	1-4, 8-22, 69-72, 94, 103, 122, 173-181, 188, 199
Z	
zero	168, 207
zigzag	27

الحمد لله رب العالمين